

Orientalmotor

Stepper Motors

PKP Series

2020/2021

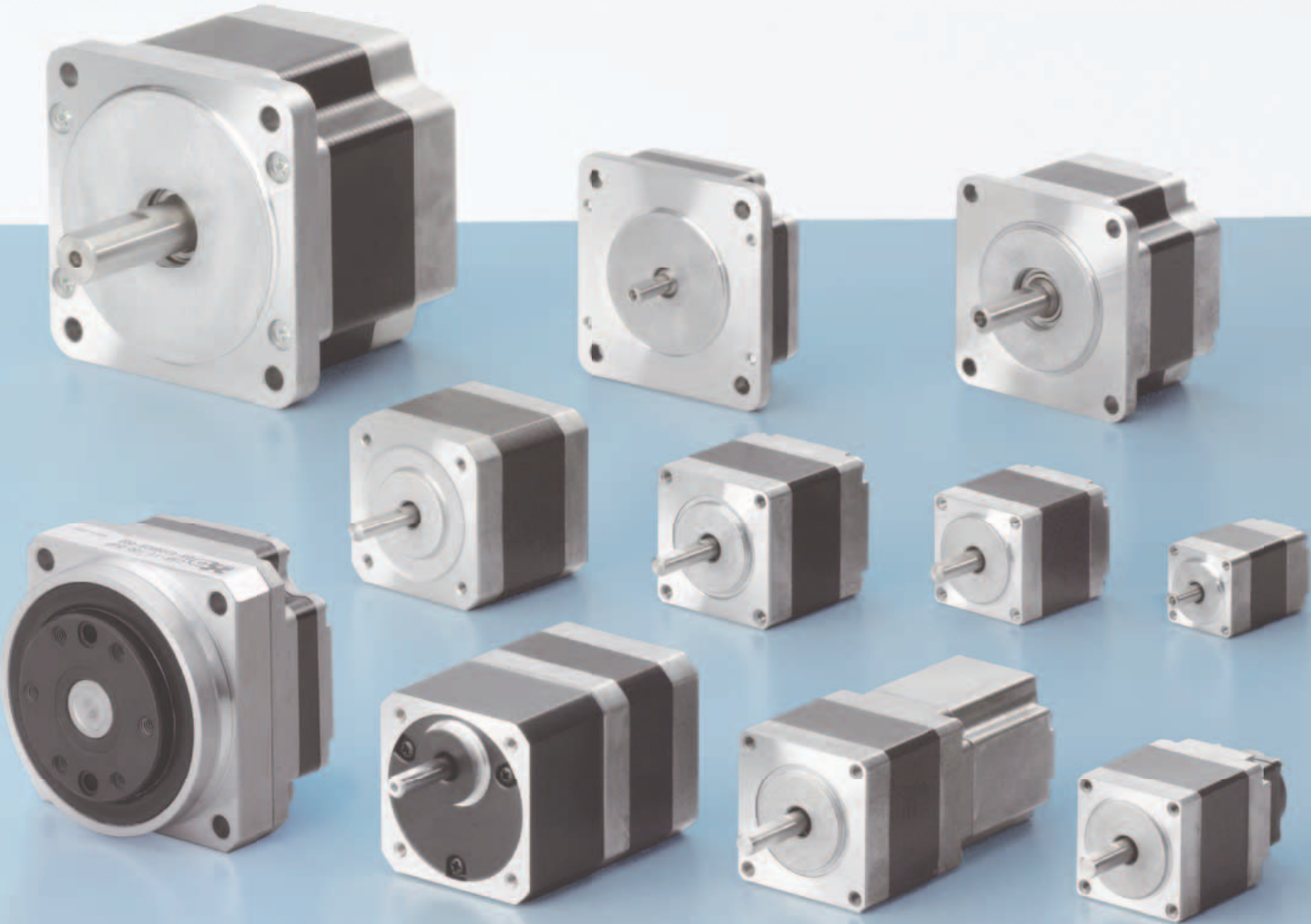

Stepper Motors

PKP Series





Stepper Motors PKP Series

High Torque

Low Vibration

●Bipolar (4 lead wires) and unipolar (5 or 6 lead wires) wiring types are available.

Features/Product Line/System Configuration/Product Numbers/Types and Prices/Included Items/Descriptions of Terms in Specifications Tables	Pages 4~15
---	------------

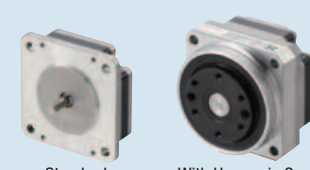
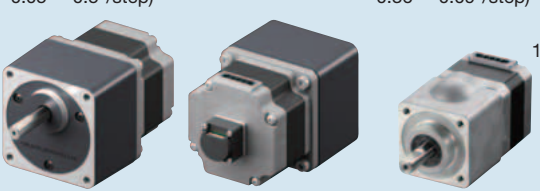
Motor Type	Motor Frame Size	Additional Function			Reference Page
		Standard	With Encoder	With Electromagnetic Brake	
Standard Type (Basic step angle: 1.8°/step) 	<input type="checkbox"/> 20 mm (0.79 in.)	●	●	—	Pages 16~17
	<input type="checkbox"/> 28 mm (1.10 in.)	●	●	●	Pages 18~20
	<input type="checkbox"/> 35 mm (1.38 in.)	●	●	●	Pages 21~25
	<input type="checkbox"/> 42 mm (1.65 in.)	●	●	NEW ●	Pages 26~30
	<input type="checkbox"/> 50 mm (1.97 in.)	●	●	—	Pages 31~32
	<input type="checkbox"/> 56.4 mm (2.22 in.)	●	●	NEW ●	Pages 33~37
	<input type="checkbox"/> 60 mm (2.36 in.)*	●	—	—	Page 38
	<input type="checkbox"/> 85 mm (3.35 in.)	●	—	—	Page 39
High-Resolution Type (Basic step angle: 0.9°/step) 	<input type="checkbox"/> 42 mm (1.65 in.)	●	●	●	Pages 40~43
	<input type="checkbox"/> 56.4 mm (2.22 in.)	●	●	●	Pages 44~47
Flat Type (Basic step angle: 0.018 ~ 1.8°/step) 	<input type="checkbox"/> 42 mm (1.65 in.)	●	—	—	Page 48
	<input type="checkbox"/> 60 mm (2.36 in.)	●	—	—	Page 49
	<input type="checkbox"/> 51 mm (2.01 in.)	With Harmonic Gears			Page 50
	<input type="checkbox"/> 61 mm (2.40 in.)	With Harmonic Gears			Page 51
SH Geared Type (Basic step angle: 0.05 ~ 0.5°/step) 	CS Geared Type (Basic step angle: 0.36 ~ 0.09°/step)	<input type="checkbox"/> 28 mm (1.10 in.)	●	—	Pages 52~63
		<input type="checkbox"/> 42 mm (1.65 in.)*	●	NEW ●	
		<input type="checkbox"/> 60 mm (2.36 in.)	●	NEW ●	

General Specifications/Electromagnetic Brake Specifications/Encoder Specifications/Rotation Direction/Permissible Radial Load and Permissible Axial Load/Permissible Moment Load of Flat Type with Harmonic Gears/Accuracy of Flat Type with Harmonic Gears/Inner Wiring Diagrams for Motor and Rotation Direction	Pages 64~67
--	-------------

*PV Type, High Rotor Inertia

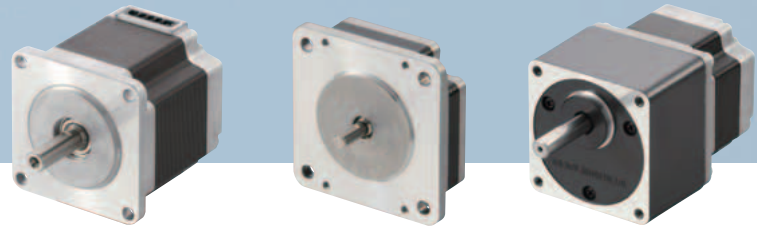

1 CS Geared Type, 42 mm (1.65 in.), standard type

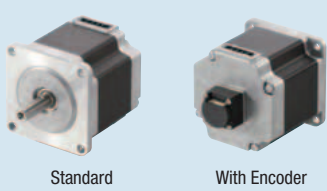
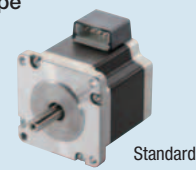
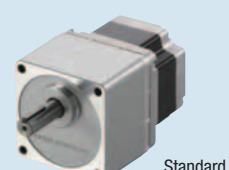

5-Phase Stepper Motors PKP Series **High Accuracy** **Low Vibration**

Features/Product Line/System Configuration/Product Numbers/Types and Prices/Included Items/Descriptions of Terms in Specifications Tables					Pages 68~72
Motor Type	Motor Frame Size	Additional Function			Reference Page
		Standard	With Encoder	With Electromagnetic Brake	
Standard Type (Basic step angle: 0.72°/step) 	□20 mm (0.79 in.)	●	●	—	Pages 73~74
	□28 mm (1.10 in.)	●	—	—	Page 75
	□42 mm (1.65 in.)	●	●	—	Pages 76~77
	□56.4 mm (2.22 in.)	●	●	—	Pages 78~79
	□60 mm (2.36 in.)	●	●	—	Pages 80~81
High-Resolution Type (Basic step angle: 0.36°/step) 	□42 mm (1.65 in.)	●	—	—	Page 82~83
	□60 mm (2.35 in.)	●	—	—	Page 84
TS Geared Type (Basic step angle: 0.024 ~ 0.2°/step) 	□42 mm (1.65 in.)	●	—	—	Page 85
	□60 mm (2.36 in.)	●	—	—	Page 86~87
General Specifications/Encoder Specifications/Motor Pin Arrangement/Rotation Direction/Permissible Radial Load and Permissible Axial Load					Pages 88~89

2-Phase 5-Phase Driver for Stepper Motors **Compact** **Low Vibration**

Driver Types and Features		Page 90~91
Bipolar Driver for 2-Phase Stepper Motors Driver for 5-Phase Stepper Motors NEW RS-485 Type See website for details.	 With Installation Plate Right Angle  With Installation Plate  Without Installation Plate	Pages 92~97
Cables		Pages 98~99
Peripheral Equipment		Pages 100~102

20 mm
(0.79 in.)

28 mm
(1.10 in.)

35 mm
(1.38 in.)

42 mm
(1.65 in.)

50 mm
(1.97 in.)
51 mm
(2.01 in.)

56.4 mm
(2.22 in.)

60 mm
(2.36 in.)
61 mm
(2.40 in.)

85 mm
(3.35 in.)

2-Phase Stepper Motors PKP Series

● For detailed information about regulations and standards, please refer to the Oriental Motor website.

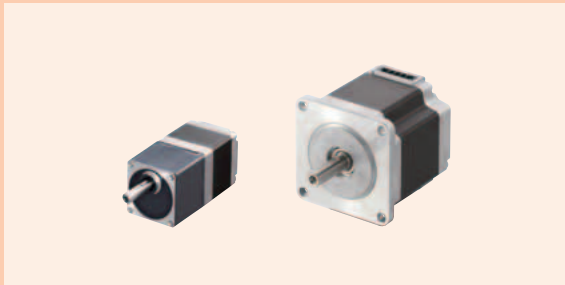

These products are high-torque 2-phase stepper motors. A wide variety of products are available to meet your design specifications.

- Standard Type with a Resolution of 200 Steps per Revolution (Basic step angle: 1.8°/step)
- High-resolution Type with a Resolution of 400 Steps per Revolution (Basic step angle: 0.9°/step)
- **SH** Geared Type for Higher Torque and Higher Resolution.
- **CS** Geared Type features a center shaft, Higher Torque than **SH** Type, and Higher Resolution.
- Bipolar (4 lead wires) and Unipolar (5 or 6 lead wires) are Available
- Type with Encoder and Type with Electromagnetic Brake are Available
- Many Motor Current Models are Available



See Full Product Details Online
www.orientalmotor.com

● Manual

● Specifications

● Dimensions

● CAD

● Characteristics

● Connection and Operation

Features

Increased Torque over the Entire Speed Range from Low to High

After revising the magnetic and structure design of the **PKP** Series, it produces much more torque than the standard **PK** Series motors of the same size. In addition, torque can be increased in the high-speed range by using high current motors.

Comparison of Speed – Torque Characteristics of the Same Size Motors

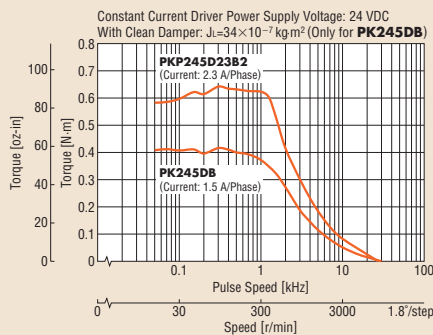

High current is possible due to the revised motor winding design and the highly efficient design of the drive circuit that can be combined. Increased torque over the entire speed range from low to high is achieved.

Comparison of Maximum Holding Torque

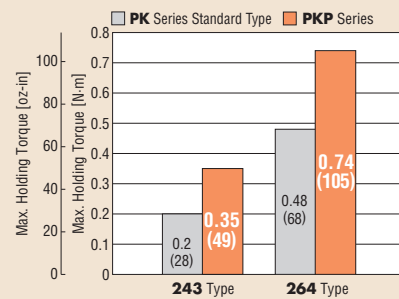

Compact and Flat Connector

The **PKP** Series uses a compact and flat connector, which shortens the length of the connector's overhang. In addition, the degree of freedom for the cable outlet direction has been increased, because the outlet direction points upward.

● Because the connector is provided for some products only, refer to dimensions of each model for details.

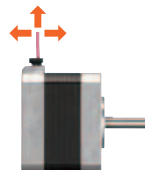

Lower Vibration

Revising the magnetic design has achieved lower vibration compared to conventional products.

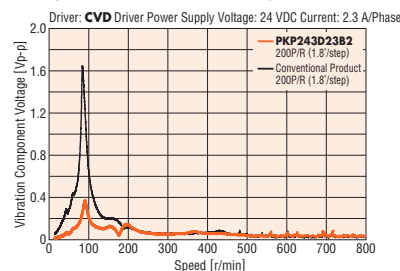

Downsizing

Use a **PKP** Series motor in place of a standard motor from the **PK** Series with the equivalent torque in order to downsize motors.

Torque Characteristics Comparison of **PKP244D15A2** and **PK264-01A**

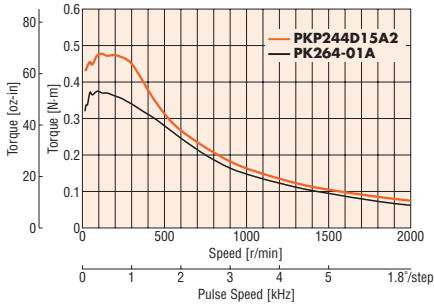

Provides torque equivalent to the next larger frame size!

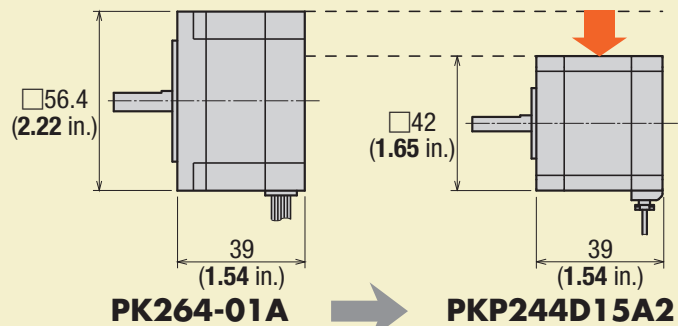

High-Resolution Type

This is a high-resolution stepper motor with a basic step angle of 0.9° . Stopping accuracy is improved.

Increased Resolution (Compared to Standard Type)

The number of rotor teeth is doubled to 100, compared to 50 with the standard type. As a result, the basic step angle is $0.9^\circ/\text{step}$, which is half that of the standard type.

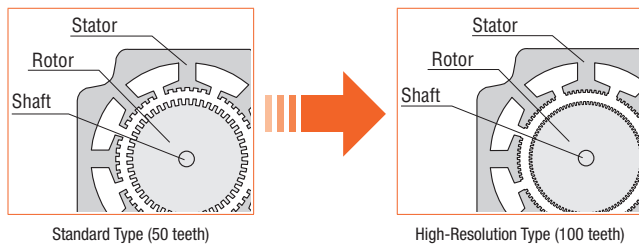

Avoidance of Resonance Regions

If the pulse speed is within a resonance region, vibration may increase. Resonance regions can be avoided by switching to a high-resolution type.

Improved Stopping Accuracy

This motor has a smaller displacement angle for frictional loads applied to the motor compared to the standard type (basic step angle 1.8°). This improves the stopping accuracy in applications where a frictional load is constantly applied, such as ball screw mechanisms.

Comparison of Angle - Torque Characteristics (Reference values)

Frictional load 0.3 N·m (42.4 oz-in)

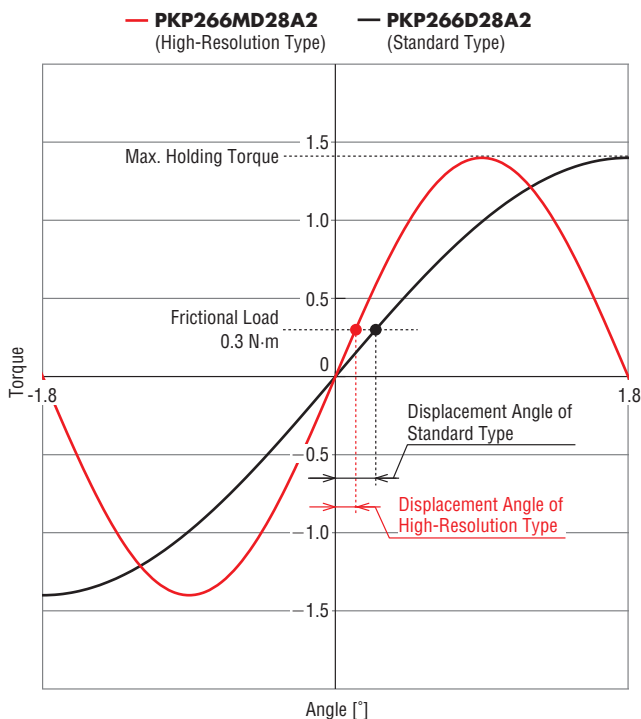

Comparison of Displacement Angles Due to Frictional Load (Reference values)

Frictional load 0.3 N·m (42.4 oz-in)

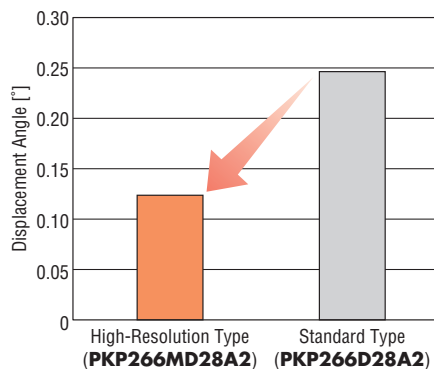

Example of a Mechanism in Which a Frictional Load is Constantly Applied

With a ball screw mechanism like that shown in the diagram, for example, a frictional load is constantly applied to the motor due to the guide block and guide rail.

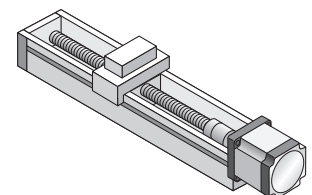

20 mm (0.79 in.)

28 mm (1.10 in.)

35 mm (1.38 in.)

42 mm (1.65 in.)

50 mm (1.97 in.)
51 mm (2.01 in.)

56.4 mm (2.22 in.)

60 mm (2.36 in.)
61 mm (2.40 in.)

85 mm (3.35 in.)

Flat Type

This is Oriental Motor's flattest type of 2-phase stepper motors.

Flat and Lightweight Design

The motor can be installed in a narrow space by being flatter.

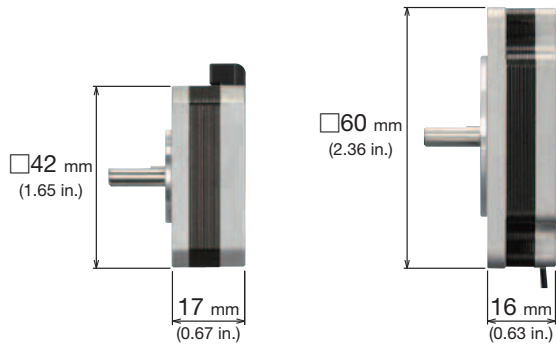

Maximum Holding Torque: 0.1 N-m (14.2 oz-in)
Mass: 0.11 kg (0.24 lbs)

Maximum Holding Torque: 0.18 N-m (25.5 oz-in)
Mass: 0.2 kg (0.44 lbs)

With Harmonic Gears

Attach the load to the surface of the flange to fix the load.

Example: Frame size 51 mm (2.01 in.)



Gear ratio 100
Max. holding torque: 2.4 N-m (339 oz-in)
Mass: 0.32 kg (11.3 oz)

Capable of large inertial driving.

Example: Frame size 51 mm (2.01 in.)

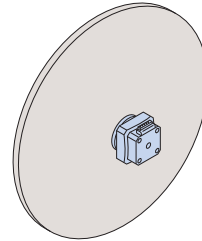

Inertia 0.12 kg-m² (2.84 lb-ft²)
(Approximately 7 times the rotor inertia)
Inertial load: Diameter 0.35 m (13.8 in.),
Thickness 0.01 m (0.39 in.)
Mass 7.6 kg (268 oz),
Material iron
Motor: Length 17 mm (0.67 in.)
Gear ratio 100

is a registered trademark of Harmonic Drive Systems Inc.

Geared Type

SH Geared Type

This type is well-suited for deceleration, increased torque, high resolution, and limited vibration. It experiences less backlash than conventional products.

The Increased Speed Range Compared to Conventional Products Makes it Even Easier to Use

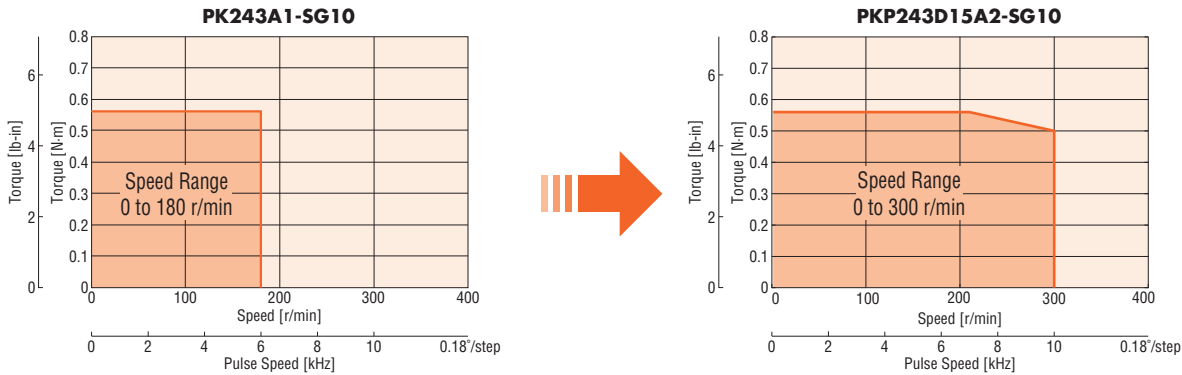

Increased Torque with the Same Motor Frame Size

With the SH Geared Type, torque can be increased without changing the motor frame size. This is effective for when motor installation space is limited and the frame size cannot be large.

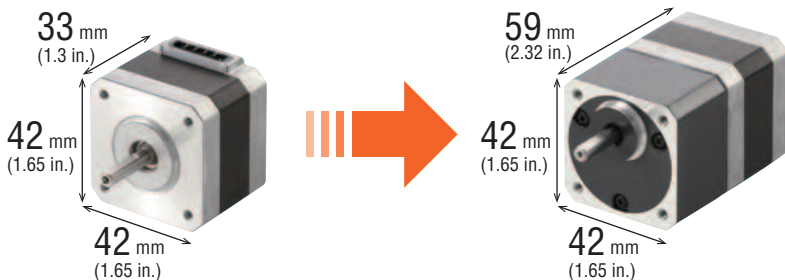

Standard Type	Motor Type	SH Geared Type
PKP243D15A2	Product Name	PKP243D15A2-SG18
0.35 N-m (49.5 oz-in)	Max. Holding Torque	0.8 N-m (113.2 oz-in)

● **CS Geared type**

The **CS** geared type has increased torque and a large shaft for greater loads without the requirement for a larger gear frame size.

◇ **Permissible Torque**

Product Name: **PKP243** Rated Current: 2.3 A for Gear Ratio 10

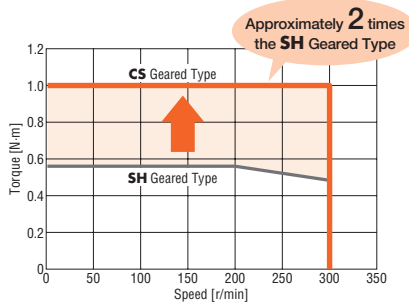

● **Neugart Planetary PLE Geared Type**

When more torque is required, consider the **PKP** Series with **PLE** Gearheads.

Visit on line or order **PKP** Series with **PLE** Gearhead catalog
www.orientalmotor.com



◇ **Permissible Radial Load and Permissible Axial Load**

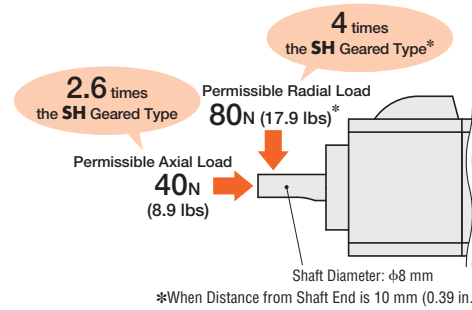

● As shown in the structural drawing, by losing gears, the output shaft can be placed at the central axis.

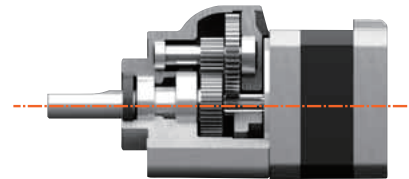

Gearhead Internal Structure Diagram

Product Line Equipped with Additional Functions for many more Applications

● **With Encoder**

(Provided for standard type, high-resolution type, and **SH** Geared Type)

Encoder Specifications → Page 64

● **Main Specifications**

Type	Standard Type	High-Resolution Type, SH Geared Type
Resolution	200 P/R, 400 P/R	400 P/R
Output Signals	A phase, B phase, Z phase (3ch)	

◇ **Motor Position Detection is Possible**

Monitoring the current position and detecting positional errors are possible. For example, comparing the command position and current position enables you to check the normal operation of the motor.

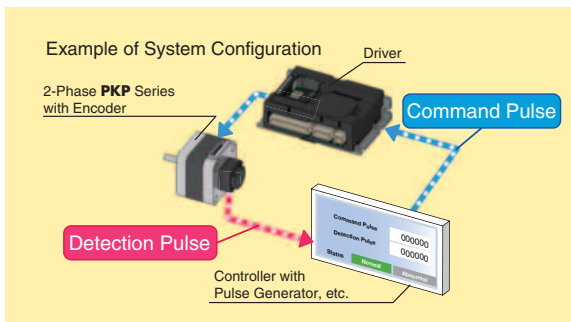

◇ **Equipped with a Compact Encoder**

● When frame size is 56.4 mm (2.22 in.)

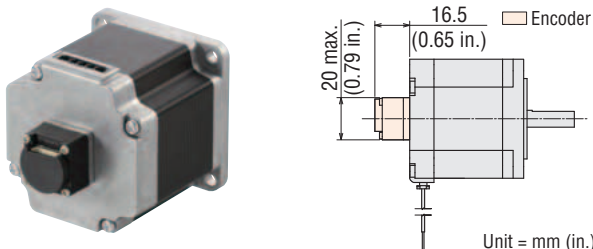

◇ **High Reliability with Line Driver Output Circuit Type**

Noise resistance is improved by differential output, and the wiring distance can be longer than with the voltage output type.

● The cables which are convenient for wiring with an encoder are available, sold separately.

Encoder Connection Cables → Page 98

● **With Electromagnetic Brake**

(Provided for standard type and high-resolution type)

Electromagnetic Brake Specifications → Page 64

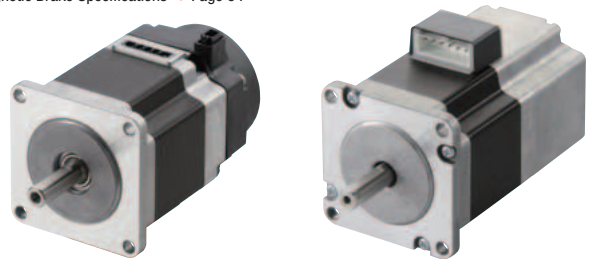

◇ **Position Can Be Held When the Power Is OFF or a Power Failure Occurs**

This type features an electromagnetic brake that activates when the power is off.

When the power is accidentally cut off due to a power failure or other unexpected event, the electromagnetic brake holds the load in position to prevent it from dropping or moving. Also, the load can be held by the electromagnetic brake when the motor is stopped, and the heat generated by the motor can be curtailed by switching the motor current off.

2-Phase Motors PKP

Features Product Line

Product Number Product Line

Standard Type

High-Resolution Type

Flat Type

SH Geared Type

CS Geared Type

General Specifications/ Inner Wiring Diagram of Motor

5-Phase Motors PKP

Features Product Line

Product Number Product Line

Standard Type

High-Resolution Type

TS Geared Type

General Specifications/ Inner Wiring Diagram of Motor

Driver for 2-Phase/ 5-Phase Motors

Accessories

Motor with a Frame Size of 50 mm (1.97 in.) with Significantly Increased Torque

Significantly Increased Torque Contributes to Small & High-Torque Applications

The new and improved design has significantly increased the torque output.

Increased torque shortens the positioning time and allows for larger load driving and holding.

Comparison with a Conventional Product from the **PK Series** with a Frame Size of 50 mm (1.97 in.)

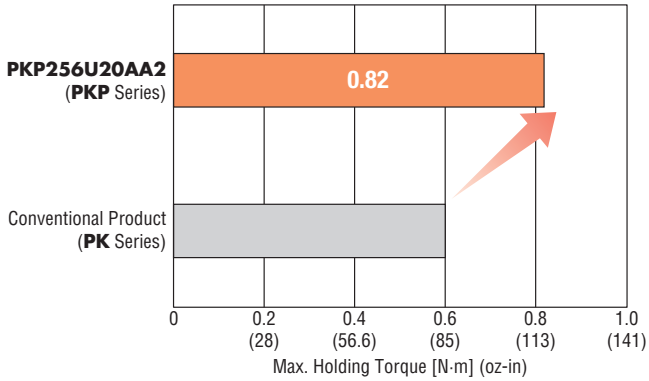

Comparison with Other Companies' Products of Equivalent Sizes*

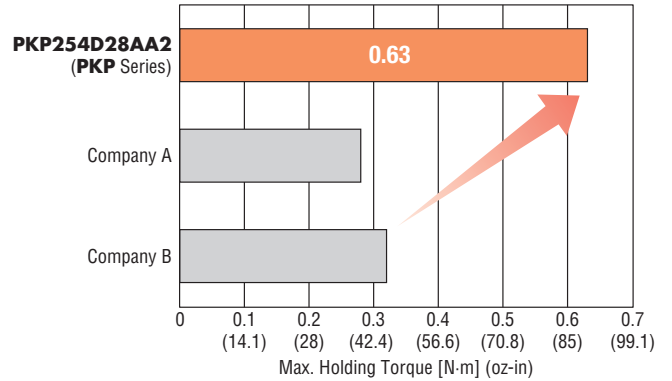

*Oriental Motor survey conducted in November 2018.

Oriental Motor Website → Video Library

There are videos on the Oriental Motor website that explain the features, operation, and usage of the **PKP** in easy-to-understand ways. Be sure to check them out.



www.orientalmotor.com/video

Combined Drivers (Sold separately) → Page 90

The compact and lightweight bipolar driver and unipolar driver are available.

● Bipolar Drivers

● Right Angle Type with Installation Plate
The connector points outward.

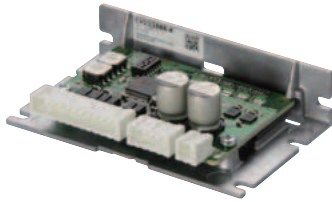



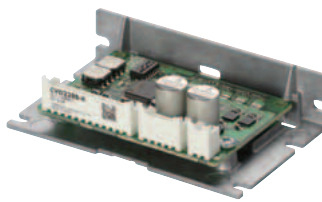

● With Installation Plate
The connector points upward.

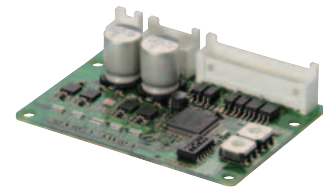

● Without Installation Plate
The connector points upward.



Product line

Motor Product Line (Basic Step Angle)	Frame Size, Wiring Type															
	20 mm (0.79 in.)		28 mm (1.10 in.)		35 mm (1.38 in.)		42 mm (1.65 in.)		50 mm (1.97 in.)		56.4 mm (2.22 in.)		60 mm (2.36 in.)		85 mm (3.35 in.)	
	Bipolar	Unipolar	Bipolar	Unipolar	Bipolar	Unipolar	Bipolar	Unipolar	Bipolar	Unipolar	Bipolar	Unipolar	Bipolar	Unipolar	Bipolar	Unipolar
Standard Type (1.8°)	○	○	●	●	●	●	●	●	●	●	●	●	○*3	○*3	○	○
 With Encoder	○	○	●	●	●	●	●	●	●	●	●	●	-	-	-	-
With Electromagnetic Brake	-	-	●	●	●	●	NEW ●	●	-	-	NEW ●	●	-	-	-	-
High-Resolution Type (0.9°)	-	-	-	-	-	-	●	●	-	-	●	●	-	-	-	-
 With Encoder	-	-	-	-	-	-	●	●	-	-	●	●	-	-	-	-
With Electromagnetic Brake	-	-	-	-	-	-	●	●	-	-	●	●	-	-	-	-
Flat Type (0.018°~1.8°)	-	-	-	-	-	-	●	-	-	-	-	-	○	-	-	-
 With Harmonic Gears	-	-	-	-	-	-	●*1	-	-	-	-	-	○*2	-	-	-
SH Geared Type (0.05°~0.5°)	-	-	●	●	-	-	●	●	-	-	-	-	●	●	-	-
 With Encoder	-	-	-	-	-	-	NEW ●	-	-	-	-	-	NEW ●	-	-	-
CS Geared Type (0.36°~0.09°)	-	-	-	-	-	-	●	-	-	-	-	-	-	-	-	-
	-	-	-	-	-	-	●	-	-	-	-	-	-	-	-	-

●: Connector Connection Method ○: Lead Wire Type
 *1 Flat type with harmonic gears is 51 mm (2.01 in.).
 *2 Flat type with harmonic gears is 61 mm (2.40 in.).
 *3 This is the PK Series of a conventional product.

2-Phase Motors PKP

Features Product Line

Product Number Product Line

Standard Type

High-Resolution Type

Flat Type

SH Geared Type

CS Geared Type

General Specifications/ Inner Wiring Diagram of Motor

5-Phase Motors PKP

Features Product Line

Product Number Product Line

Standard Type

High-Resolution Type

TS Geared Type

General Specifications/ Inner Wiring Diagram of Motor

Driver for 2-Phase/ 5-Phase Motors

Accessories

20 mm (0.79 in.)

28 mm (1.10 in.)

35 mm (1.38 in.)

42 mm (1.65 in.)

50 mm (1.97 in.)
51 mm (2.01 in.)

56.4 mm (2.22 in.)

60 mm (2.36 in.)
61 mm (2.40 in.)

85 mm (3.35 in.)

System Configuration

These accessories allow 2-phase stepper motors in the **PKP** Series to be used for various operations. Motors and cables must be ordered individually.

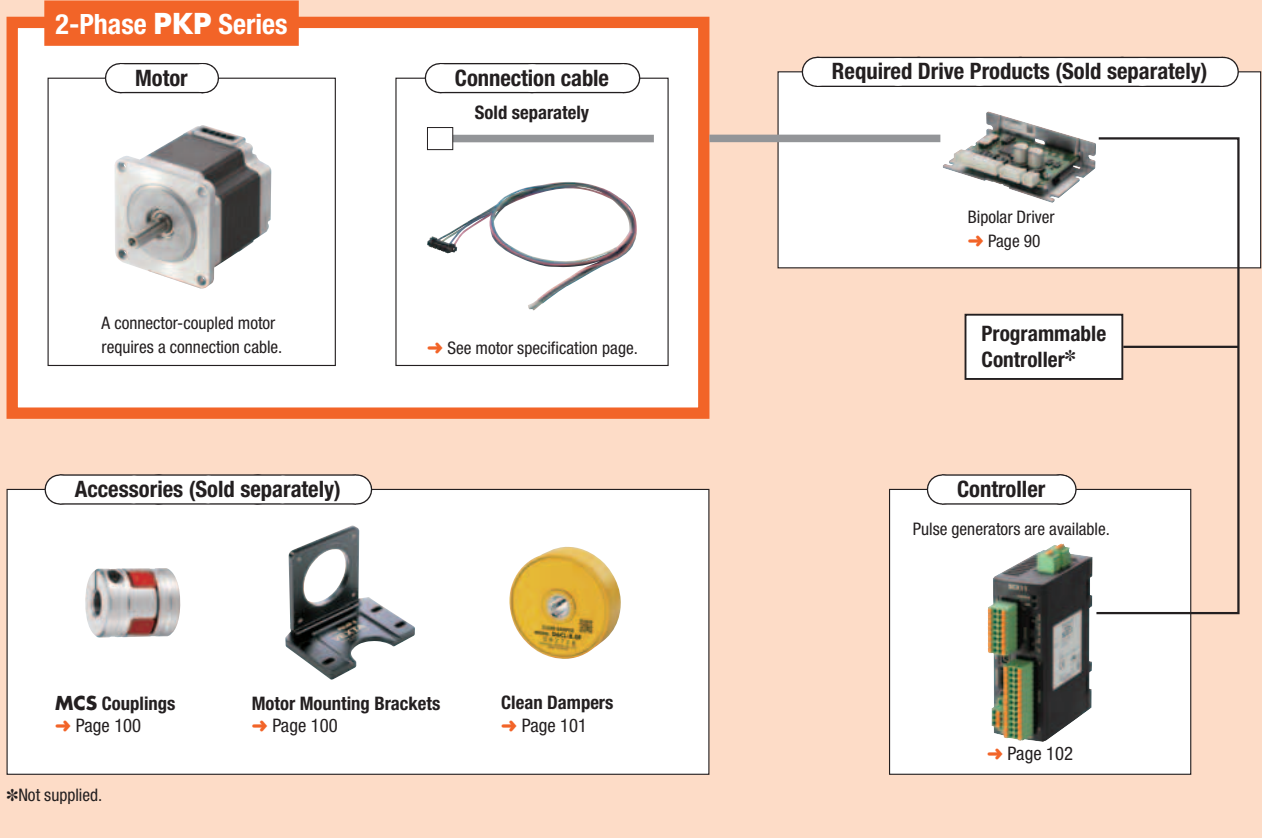

Example of System Configuration

2-Phase PKP Series		Accessories		
Motor	Connection cable	Motor Mounting Brackets	Flexible Couplings	Clean Dampers
PKP264D28BA2	LC2B06E	PALW2P-2	MCS20F0410	D6CL-6.3F
\$58.00	\$6.00	\$17.00	\$50.00	\$42.00

The system configuration shown above is an example. Other combinations are also available.

Product Number

Motor

PKP Series

◇ Standard Type/Standard Type with Electromagnetic Brake

PKP 2 5 4 D 28 A A 2

① ② ③ ④ ⑥ ⑦ ⑧ ⑨ ⑩

◇ High-Resolution Type/High-Resolution Type with Electromagnetic Brake

PKP 2 6 4 M D 28 A 2

① ② ③ ④ ⑤ ⑥ ⑦ ⑧ ⑩

①	Series Name	PKP: PKP Series
②	2: 2-Phase	
③	Motor Frame Size	1: 20 mm (0.79 in.) 2: 28 mm (1.10 in.) 3: 35 mm (1.38 in.) 4: 42 mm (1.65 in.) 5: 50 mm (1.97 in.) 6: 56.4 mm (2.22 in.) 9: 85 mm (3.35 in.)
④	Motor Case Length	
⑤	Motor Type	Blank: Standard Type M: High-Resolution Type
⑥	Number of Lead Wires	D: 4 U: 5 or 6
⑦	Motor Winding Specification	
⑧	Shaft/Electromagnetic Brake	A: Single Shaft B: Double Shaft M: with Electromagnetic Brake
⑨	Output Shaft Diameter	A: Imperial Blank: Metric
⑩	Reference Number	

◇ Standard Type with Encoder

PKP 2 5 4 D 28 A A 2 - R2F L

① ② ③ ④ ⑥ ⑦ ⑧ ⑨ ⑩ ⑪ ⑫

◇ High-Resolution Type with Encoder

PKP 2 4 3 M D 15 A 2 - R2F L

① ② ③ ④ ⑤ ⑥ ⑦ ⑧ ⑩ ⑪ ⑫

①	Series Name	PKP: PKP Series	
②	2: 2-Phase		
③	Motor Frame Size	1: 20 mm (0.79 in.) 3: 35 mm (1.38 in.) 5: 50 mm (1.97 in.) 9: 85 mm (3.35 in.)	2: 28 mm (1.10 in.) 4: 42 mm (1.65 in.) 6: 56.4 mm (2.22 in.)
④	Motor Case Length		
⑤	Motor Type	Blank: Standard Type M: High-Resolution Type	
⑥	Number of Lead Wires	D: 4 U: 5 or 6	
⑦	Motor Winding Specification		
⑧	Shaft	A: Single Shaft	
⑨	Output Shaft Diameter	A: Imperial Blank: Metric	
⑩	Reference Number		
⑪	Encoder Resolution	R2E: 200 P/R R2F: 400 P/R	
⑫	Encoder Output Circuit Type	L: Line Driver Output Blank: Voltage Output	

◇ Flat Type

PKP 2 4 2 D 23 A 2

① ② ③ ④ ⑥ ⑦ ⑧ ⑩

PKP 2 6 2 F D 15 A W

① ② ③ ④ ⑤ ⑥ ⑦ ⑧ ⑨

◇ Flat Type with Harmonic Gear

PKP 2 4 2 D 23 A 2 - H 100

① ② ③ ④ ⑥ ⑦ ⑧ ⑩ ⑪ ⑫

PKP 2 6 2 F D 15 A W - H 100 S

① ② ③ ④ ⑤ ⑥ ⑦ ⑧ ⑨ ⑪ ⑫ ⑬

①	Series Name	PKP: PKP Series	
②	2: 2-Phase		
③	Motor Frame Size	4: 42 mm (1.65 in.) [Harmonic Geared type is 51 mm (2.01 in.)] 6: 60 mm (2.36 in.) [Harmonic Geared type is 61 mm (2.40 in.)]	
④	Motor Case Length		
⑤	Motor Identification	F: Motor Frame Size 60 mm (2.36 in.)	
⑥	Number of Lead Wires	D: 4	
⑦	Motor Winding Specification		
⑧	Shaft	A: Single Shaft	
⑨	Cable Type	Blank: Connector Coupled Type W: Lead Wire Type	
⑩	Reference Number		
⑪	Geared Type	Blank: Flat Type H: Flat Type Harmonic Geared	
⑫	Gear Ratio		
⑬	Gear Classification		

PV Series (High inertia capability)

PV 2 6 6 - 0 2 B A

① ② ③ ④ ⑤ ⑥ ⑦ ⑧

①	Series Name	PV: PV Series	
②	2: 2-Phase		
③	Motor Frame Size	6: 60 mm (2.36 in.)	
④	Motor Case Length		
⑤	Motor Lead	0: 6 Leads D: 4 Leads	
⑥	Winding Specification		
⑦	Shaft Type	A: Single Shaft B: Double Shaft	
⑧	U.S.A. Version		

◇ SH Geared Type/CS Geared Type

PKP 2 4 3 U 09 B 2 - SG 18

① ② ③ ④ ⑤ ⑥ ⑦ ⑧ ⑨ ⑩

①	Series Name	PKP: PKP Series	
②	2: 2-Phase		
③	Motor Frame Size	2: 28 mm (1.10 in.) 6: 60 mm (2.36 in.)	4: 42 mm (1.65 in.)
④	Motor Case Length		
⑤	Number of Lead Wires	D: 4 U: 5 or 6	
⑥	Motor Winding Specification		
⑦	Shaft	A: Single Shaft B: Double Shaft	
⑧	Reference Number		
⑨	Geared Type	SG: SH Geared Type CS: CS Geared Type	
⑩	Gear Ratio		

◇ SH Geared Type with Encoder

PKP 2 6 4 D 28 A 2 - SG 18 - R2F L

① ② ③ ④ ⑤ ⑥ ⑦ ⑧ ⑨ ⑩ ⑪ ⑫

①	Series Name	PKP: PKP Series	
②	2: 2-Phase		
③	Motor Frame Size	4: 42 mm (1.65 in.) 6: 60 mm (2.36 in.)	
④	Motor Case Length		
⑤	Number of Lead Wires	D: 4	
⑥	Motor Winding Specification		
⑦	Shaft	A: Single Shaft	
⑧	Reference Number		
⑨	Geared Type	SG: SH Geared Type	
⑩	Gear Ratio		
⑪	Encoder Resolution	R2E: 200 P/R R2F: 400 P/R	
⑫	Encoder Output Circuit Type	L: Line Driver Output Blank: Voltage Output	

◇ CS Geared Type

PKP 2 4 3 D 15 A 2 - CS 5

① ② ③ ④ ⑤ ⑥ ⑦ ⑧ ⑨ ⑩

①	Series Name	PKP: PKP Series	
②	2: 2-Phase		
③	Motor Frame Size	4: 42 mm (1.65 in.)	
④	Motor Case Length		
⑤	Number of Lead Wires	D: 4	
⑥	Motor Winding Specification		
⑦	Shaft		
⑧	Reference Number	A: Single Shaft B: Double Shaft	
⑨	Geared Type	CS: CS Geared Type	
⑩	Gear Ratio		

2-Phase Motors PKP

Features Product Line

Product Number Product Line

Standard Type

High-Resolution Type

Flat Type

SH Geared Type

CS Geared Type

General Specifications/ Inner Wiring Diagram of Motor

5-Phase Motors PKP

Features Product Line

Product Number Product Line

Standard Type

High-Resolution Type

TS Geared Type

General Specifications/ Inner Wiring Diagram of Motor

Driver for 2-Phase/ 5-Phase Motors

Accessories

- Motor Frame Size
- 20 mm (0.79 in.)
- 28 mm (1.10 in.)
- 35 mm (1.38 in.)
- 42 mm (1.65 in.)
- 50 mm (1.97 in.)
- 51 mm (2.01 in.)
- 56.4 mm (2.22 in.)
- 60 mm (2.36 in.)
- 61 mm (2.40 in.)
- 85 mm (3.35 in.)

● Connection cable

◇ Motor Connection Cables

LC 2 B 06 A

- ① ② ③ ④ ⑤

①	Cables	LC: Connector leads
②	2: 2-phase	
③	Cable Type	B: For Bipolar U: For unipolar
④	Cable Length	06: 0.6 m (2 ft.) 10: 1 m (3.3 ft.)
⑤	Reference Number	

◇ Electromagnetic Brake Connection Cables

LC M 02 A - 006

- ① ② ③ ④ ⑤

①	Cables	LC: Connector leads
②	Cable Type	M: For electromagnetic brake
③	Number of Lead Wires	
④	Reference Number	
⑤	Cable Length	006: 0.6 m (2 ft.) 010: 1 m (3.3 ft.)

Types and Prices

A connector-coupled motor requires a connection cable.

Motors and cables must be ordered individually. Refer to motor specification page for connection cables.

● Motor

◇ Standard Type

● Bipolar (4 Lead Wires)

Product Name (Single shaft)	List Price	Product Name (Double shaft)	List Price
PKP213D05A	\$65.00	PKP213D05B	\$67.00
PKP214D06A	\$72.00	PKP214D06B	\$74.00
PKP223D15A2	\$50.00	PKP223D15B2	\$52.00
PKP225D15A2	\$57.00	PKP225D15B2	\$59.00
PKP233D15A	\$48.00	PKP233D15B	\$50.00
PKP233D23A	\$48.00	PKP233D23B	\$50.00
PKP235D15A	\$55.00	PKP235D15B	\$57.00
PKP235D23A	\$55.00	PKP235D23B	\$57.00
PKP243D08A2	\$45.00	PKP243D08B2	\$47.00
PKP243D15A2	\$45.00	PKP243D15B2	\$47.00
PKP243D23A2	\$45.00	PKP243D23B2	\$47.00
PKP244D08A2	\$47.00	PKP244D08B2	\$49.00
PKP244D15A2	\$47.00	PKP244D15B2	\$49.00
PKP244D23A2	\$47.00	PKP244D23B2	\$49.00
PKP245D08A2	\$53.00	PKP245D08B2	\$55.00
PKP245D15A2	\$53.00	PKP245D15B2	\$55.00
PKP245D23A2	\$53.00	PKP245D23B2	\$55.00
PKP246D15A2	\$56.00	PKP246D15B2	\$58.00
PKP246D23A2	\$56.00	PKP246D23B2	\$58.00
PKP254D28AA2	\$53.00	PKP254D28BA2	\$55.00
PKP256D28AA2	\$59.00	PKP256D28BA2	\$63.00
PKP258D28AA2	\$74.00	PKP258D28BA2	\$77.00
PKP264D14A2	\$56.00	PKP264D14B2	\$58.00
PKP264D28A2	\$56.00	PKP264D28B2	\$58.00
PKP264D42A2	\$56.00	PKP264D42B2	\$58.00
PKP266D14A2	\$62.00	PKP266D14B2	\$64.00
PKP266D28A2	\$62.00	PKP266D28B2	\$64.00
PKP266D42A2	\$62.00	PKP266D42B2	\$64.00
PKP268D14A2	\$76.00	PKP268D14B2	\$79.00
PKP268D28A2	\$76.00	PKP268D28B2	\$79.00
PKP268D42A2	\$76.00	PKP268D42B2	\$79.00
PV264-D2.8AA	\$90.00	PV264-D2.8BA	\$93.00
PV266-D2.8AA	\$99.00	PV266-D2.8BA	\$102.00
PV267-D2.8AA	\$117.00	PV267-D2.8BA	\$121.00
PV269-D2.8AA	\$147.00	PV269-D2.8BA	\$151.00
PKP296D45AA	\$108.00	PKP296D45BA	\$112.00
PKP296D63AA	\$108.00	PKP296D63BA	\$112.00
PKP299D45AA	\$165.00	PKP299D45BA	\$171.00
PKP299D63AA	\$165.00	PKP299D63BA	\$171.00
PKP2913D45AA	\$209.00	PKP2913D45BA	\$218.00
PKP2913D56AA	\$209.00	PKP2913D56BA	\$218.00

◇ Encoder Connection Cables

LC E 08 A - 006

- ① ② ③ ④ ⑤

①	Cables	LC: Connector leads
②	Cable Type	E: For encoder
③	Applicable Models	05: Voltage 08: For Line driver output
④	Reference Number	
⑤	Cable Length	006: 0.6 m (2 ft.)

● Unipolar (5 or 6 Lead Wires)

Product Name (Single shaft)	List Price	Product Name (Double shaft)	List Price
PKP213U05A	\$65.00	PKP213U05B	\$67.00
PKP214U06A	\$72.00	PKP214U06B	\$74.00
PKP223U09A2	\$50.00	PKP223U09B2	\$52.00
PKP225U09A2	\$57.00	PKP225U09B2	\$59.00
PKP233U12A	\$48.00	PKP233U12B	\$50.00
PKP235U12A	\$55.00	PKP235U12B	\$57.00
PKP243U08A2	\$45.00	PKP243U08B2	\$47.00
PKP243U12A2	\$45.00	PKP243U12B2	\$47.00
PKP244U08A2	\$47.00	PKP244U08B2	\$49.00
PKP244U12A2	\$47.00	PKP244U12B2	\$49.00
PKP245U08A2	\$53.00	PKP245U08B2	\$55.00
PKP245U12A2	\$53.00	PKP245U12B2	\$55.00
PKP246U12A2	\$56.00	PKP246U12B2	\$58.00
PKP246U16A2	\$56.00	PKP246U16B2	\$58.00
PKP254U20AA2	\$53.00	PKP254U20BA2	\$55.00
PKP256U20AA2	\$59.00	PKP256U20BA2	\$63.00
PKP258U20AA2	\$74.00	PKP258U20BA2	\$77.00
PKP264U10A2	\$56.00	PKP264U10B2	\$58.00
PKP264U20A2	\$56.00	PKP264U20B2	\$58.00
PKP266U10A2	\$62.00	PKP266U10B2	\$64.00
PKP266U20A2	\$62.00	PKP266U20B2	\$64.00
PKP268U10A2	\$76.00	PKP268U10B2	\$79.00
PKP268U20A2	\$76.00	PKP268U20B2	\$79.00
PV264-02AA	\$90.00	PV264-02BA	\$93.00
PV266-02AA	\$99.00	PV266-02BA	\$102.00
PV267-02AA	\$117.00	PV267-02BA	\$121.00
PV269-02AA	\$147.00	PV269-02BA	\$151.00
PKP296U20A	\$108.00	PKP296U20BA	\$112.00
PKP296U30A	\$108.00	PKP296U30BA	\$112.00
PKP296U45A	\$108.00	PKP296U45BA	\$112.00
PKP299U20A	\$165.00	PKP299U20BA	\$171.00
PKP299U30A	\$165.00	PKP299U30BA	\$171.00
PKP299U45A	\$165.00	PKP299U45BA	\$171.00
PKP2913U20A	\$209.00	PKP2913U20BA	\$218.00
PKP2913U40A	\$209.00	PKP2913U40BA	\$218.00

◇ Standard Type with Encoder

● Bipolar (4 Lead Wires)

Product Name	List Price
PKP213D05A-R2E	\$148.00
PKP214D06A-R2E	\$155.00
PKP223D15A2-R2	\$123.00
PKP225D15A2-R2	\$133.00
PKP233D15A-R2	\$123.00
PKP233D23A-R2	\$123.00
PKP235D15A-R2	\$130.00
PKP235D23A-R2	\$130.00
PKP243D08A2-R2	\$104.00
PKP243D15A2-R2	\$104.00
PKP243D23A2-R2	\$104.00
PKP244D08A2-R2	\$106.00
PKP244D15A2-R2	\$106.00
PKP244D23A2-R2	\$106.00
PKP245D08A2-R2	\$113.00
PKP245D15A2-R2	\$113.00
PKP245D23A2-R2	\$113.00
PKP246D15A2-R2	\$115.00
PKP246D23A2-R2	\$115.00
PKP254D28AA2-R2	\$113.00
PKP256D28AA2-R2	\$118.00
PKP258D28AA2-R2	\$136.00
PKP264D14A2-R2	\$115.00
PKP264D28A2-R2	\$115.00
PKP264D42A2-R2	\$115.00
PKP266D14A2-R2	\$121.00
PKP266D28A2-R2	\$121.00
PKP266D42A2-R2	\$121.00
PKP268D14A2-R2	\$138.00
PKP268D28A2-R2	\$138.00
PKP268D42A2-R2	\$138.00

● Either **E** (200 P/R) or **F** (400 P/R) indicating the encoder resolution is specified where the box is located in the product name.

A code **L** (line driver output) indicating the encoder output circuit type is entered where the box is located within the product name. The voltage output type will have no " " in the product name.

◇ Standard Type with Electromagnetic Brake

● Bipolar (4 Lead Wires)

Product Name	List Price
PKP223D15M2	\$115.00
PKP225D15M2	\$122.00
PKP233D15M	\$148.00
PKP235D15M	\$155.00
PKP243D23M2 NEW	\$144.00
PKP244D23M2 NEW	\$146.00
PKP245D23M2 NEW	\$153.00
PKP246D23M2 NEW	\$154.00
PKP264D28M2 NEW	\$167.00
PKP266D28M2 NEW	\$171.00
PKP268D28M2 NEW	\$190.00

◇ High-Resolution Type

● Bipolar (4 Lead Wires)

Product Name (Single shaft)	List Price	Product Name (Double shaft)	List Price
PKP243MD15A2	\$45.00	PKP243MD15B2	\$50.00
PKP244MD15A2	\$50.00	PKP244MD15B2	\$51.00
PKP245MD15A2	\$53.00	PKP245MD15B2	\$55.00
PKP246MD15A2	\$54.00	PKP246MD15B2	\$58.00
PKP264MD28A2	\$56.00	PKP264MD28B2	\$58.00
PKP266MD28A2	\$62.00	PKP266MD28B2	\$64.00
PKP268MD28A2	\$78.00	PKP268MD28B2	\$80.00

◇ High-Resolution Type with Encoder

● Bipolar (4 Lead Wires)

Product Name	List Price
PKP243MD15A2-R2F	\$104.00
PKP244MD15A2-R2F	\$106.00
PKP245MD15A2-R2F	\$113.00
PKP246MD15A2-R2F	\$115.00
PKP264MD28A2-R2F	\$131.00
PKP266MD28A2-R2F	\$137.00
PKP268MD28A2-R2F	\$153.00

● A code **L** (line driver output) indicating the encoder output circuit type is entered where the box is located within the product name. The voltage output type will have no " " in the product name.

● Unipolar (5 or 6 Lead Wires)

Product Name	List Price
PKP213U05A-R2E	\$148.00
PKP214U06A-R2E	\$155.00
PKP223U09A2-R2	\$123.00
PKP225U09A2-R2	\$133.00
PKP233U12A-R2	\$123.00
PKP235U12A-R2	\$130.00
PKP243U08A2-R2	\$104.00
PKP243U09A2-R2	\$104.00
PKP243U12A2-R2	\$104.00
PKP244U08A2-R2	\$106.00
PKP244U12A2-R2	\$106.00
PKP245U08A2-R2	\$113.00
PKP245U12A2-R2	\$113.00
PKP246U12A2-R2	\$115.00
PKP246U16A2-R2	\$115.00
PKP254U20AA2-R2	\$113.00
PKP256U20AA2-R2	\$118.00
PKP258U20AA2-R2	\$136.00
PKP264U10A2-R2	\$115.00
PKP264U20A2-R2	\$115.00
PKP266U10A2-R2	\$121.00
PKP266U20A2-R2	\$121.00
PKP268U10A2-R2	\$138.00
PKP268U20A2-R2	\$138.00

● Either **E** (200 P/R) or **F** (400 P/R) indicating the encoder resolution is specified where the box is located in the product name.

A code **L** (line driver output) indicating the encoder output circuit type is entered where the box is located within the product name. The voltage output type will have no " " in the product name.

● Unipolar (6 Lead Wires)

Product Name	List Price
PKP223U09M2	\$115.00
PKP225U09M2	\$122.00
PKP233U12M	\$148.00
PKP235U12M	\$155.00
PKP243U09M	\$148.00
PKP244U12M	\$149.00
PKP245U12M	\$155.00
PKP246U12M	\$157.00
PKP264U20M	\$171.00
PKP266U20M	\$177.00
PKP268U20M	\$193.00

● Unipolar (5 Lead Wires)

Product Name (Single shaft)	List Price	Product Name (Double shaft)	List Price
PKP243MU12A2	\$45.00	PKP243MU12B2	\$50.00
PKP244MU12A2	\$50.00	PKP244MU12B2	\$51.00
PKP245MU12A2	\$53.00	PKP245MU12B2	\$55.00
PKP246MU12A2	\$54.00	PKP246MU12B2	\$58.00
PKP264MU20A2	\$56.00	PKP264MU20B2	\$58.00
PKP266MU20A2	\$62.00	PKP266MU20B2	\$64.00
PKP268MU20A2	\$78.00	PKP268MU20B2	\$80.00

● Unipolar (5 Lead Wires)

Product Name	List Price
PKP243MU12A2-R2F	\$104.00
PKP244MU12A2-R2F	\$106.00
PKP245MU12A2-R2F	\$113.00
PKP246MU12A2-R2F	\$115.00
PKP264MU20A2-R2F	\$131.00
PKP266MU20A2-R2F	\$137.00
PKP268MU20A2-R2F	\$153.00

- Motor Frame Size
- 20 mm (0.79 in.)
 - 28 mm (1.10 in.)
 - 35 mm (1.38 in.)
 - 42 mm (1.65 in.)
 - 50 mm (1.97 in.)
 - 51 mm (2.01 in.)
 - 56.4 mm (2.22 in.)
 - 60 mm (2.36 in.)
 - 61 mm (2.40 in.)
 - 85 mm (3.35 in.)

◇ High-Resolution Type with Electromagnetic Brake

● Bipolar (4 Lead Wires)

Product Name	List Price
PKP243MD15M	\$148.00
PKP244MD15M	\$149.00
PKP264MD28M	\$171.00
PKP266MD28M	\$177.00
PKP268MD28M	\$193.00

◇ Flat Type

● Bipolar (4 Lead Wires)

Product Name (Single shaft)	List Price
PKP242D23A2	\$52.00
PKP262FD15AW	\$58.00

◇ Flat Type with Harmonic Gears

● Bipolar (4 Lead Wires)

Product Name (Single shaft)	List Price
PKP242D23A2-H50	\$759.00
PKP242D23A2-H100	\$759.00
PKP262FD15AW-H50S	\$818.00
PKP262FD15AW-H100S	\$818.00

◇ SH Geared Type

● Bipolar (4 Lead Wires)

Product Name (Single shaft)	List Price	Product Name (Double shaft)	List Price
PKP223D15A-SG7.2	\$168.00	PKP223D15B-SG7.2	\$170.00
PKP223D15A-SG9	\$168.00	PKP223D15B-SG9	\$170.00
PKP223D15A-SG10	\$168.00	PKP223D15B-SG10	\$170.00
PKP223D15A-SG18	\$182.00	PKP223D15B-SG18	\$184.00
PKP223D15A-SG36	\$182.00	PKP223D15B-SG36	\$184.00
PKP243D15A2-SG3.6	\$121.00	PKP243D15B2-SG3.6	\$123.00
PKP243D23A2-SG3.6	\$121.00	PKP243D23B2-SG3.6	\$123.00
PKP243D15A2-SG7.2	\$121.00	PKP243D15B2-SG7.2	\$123.00
PKP243D23A2-SG7.2	\$121.00	PKP243D23B2-SG7.2	\$123.00
PKP243D15A2-SG9	\$121.00	PKP243D15B2-SG9	\$123.00
PKP243D23A2-SG9	\$121.00	PKP243D23B2-SG9	\$123.00
PKP243D15A2-SG10	\$121.00	PKP243D15B2-SG10	\$123.00
PKP243D23A2-SG10	\$121.00	PKP243D23B2-SG10	\$123.00
PKP243D15A2-SG18	\$138.00	PKP243D15B2-SG18	\$140.00
PKP243D23A2-SG18	\$138.00	PKP243D23B2-SG18	\$140.00
PKP243D15A2-SG36	\$138.00	PKP243D15B2-SG36	\$140.00
PKP243D23A2-SG36	\$138.00	PKP243D23B2-SG36	\$140.00
PKP264D14A2-SG3.6	\$138.00	PKP264D14B2-SG3.6	\$141.00
PKP264D28A2-SG3.6	\$138.00	PKP264D28B2-SG3.6	\$141.00
PKP264D14A2-SG7.2	\$138.00	PKP264D14B2-SG7.2	\$141.00
PKP264D28A2-SG7.2	\$138.00	PKP264D28B2-SG7.2	\$141.00
PKP264D14A2-SG9	\$138.00	PKP264D14B2-SG9	\$141.00
PKP264D28A2-SG9	\$138.00	PKP264D28B2-SG9	\$141.00
PKP264D14A2-SG10	\$138.00	PKP264D14B2-SG10	\$141.00
PKP264D28A2-SG10	\$138.00	PKP264D28B2-SG10	\$141.00
PKP264D14A2-SG18	\$154.00	PKP264D14B2-SG18	\$157.00
PKP264D28A2-SG18	\$154.00	PKP264D28B2-SG18	\$157.00
PKP264D14A2-SG36	\$154.00	PKP264D14B2-SG36	\$157.00
PKP264D28A2-SG36	\$154.00	PKP264D28B2-SG36	\$157.00

● Unipolar (6 Lead Wires)

Product Name	List Price
PKP243MU09M	\$148.00
PKP244MU12M	\$149.00
PKP264MU20M	\$171.00
PKP266MU20M	\$177.00
PKP268MU20M	\$193.00

● Unipolar (5 or 6 Lead Wires)

Product Name (Single shaft)	List Price	Product Name (Double shaft)	List Price
PKP223U09A-SG7.2	\$168.00	PKP223U09B-SG7.2	\$170.00
PKP223U09A-SG9	\$168.00	PKP223U09B-SG9	\$170.00
PKP223U09A-SG10	\$168.00	PKP223U09B-SG10	\$170.00
PKP223U09A-SG18	\$182.00	PKP223U09B-SG18	\$184.00
PKP223U09A-SG36	\$182.00	PKP223U09B-SG36	\$184.00
PKP243U09A2-SG3.6	\$121.00	PKP243U09B2-SG3.6	\$123.00
PKP243U09A2-SG7.2	\$121.00	PKP243U09B2-SG7.2	\$123.00
PKP243U09A2-SG9	\$121.00	PKP243U09B2-SG9	\$123.00
PKP243U09A2-SG10	\$121.00	PKP243U09B2-SG10	\$123.00
PKP243U09A2-SG18	\$138.00	PKP243U09B2-SG18	\$140.00
PKP243U09A2-SG36	\$138.00	PKP243U09B2-SG36	\$140.00
PKP264U10A2-SG3.6	\$138.00	PKP264U10B2-SG3.6	\$141.00
PKP264U20A2-SG3.6	\$138.00	PKP264U20B2-SG3.6	\$141.00
PKP264U10A2-SG7.2	\$138.00	PKP264U10B2-SG7.2	\$141.00
PKP264U20A2-SG7.2	\$138.00	PKP264U20B2-SG7.2	\$141.00
PKP264U10A2-SG9	\$138.00	PKP264U10B2-SG9	\$141.00
PKP264U20A2-SG9	\$138.00	PKP264U20B2-SG9	\$141.00
PKP264U10A2-SG10	\$138.00	PKP264U10B2-SG10	\$141.00
PKP264U20A2-SG10	\$138.00	PKP264U20B2-SG10	\$141.00
PKP264U10A2-SG18	\$154.00	PKP264U10B2-SG18	\$157.00
PKP264U20A2-SG18	\$154.00	PKP264U20B2-SG18	\$157.00
PKP264U10A2-SG36	\$154.00	PKP264U10B2-SG36	\$157.00
PKP264U20A2-SG36	\$154.00	PKP264U20B2-SG36	\$157.00
PK296A1A-SG3.6	\$257.00	PK296B1A-SG3.6	\$261.00
PK296A2A-SG3.6	\$257.00	PK296B2A-SG3.6	\$261.00
PK296A1A-SG7.2	\$257.00	PK296B1A-SG7.2	\$261.00
PK296A2A-SG7.2	\$257.00	PK296B2A-SG7.2	\$261.00
PK296A1A-SG9	\$257.00	PK296B1A-SG9	\$261.00
PK296A2A-SG9	\$257.00	PK296B2A-SG9	\$261.00
PK296A1A-SG10	\$257.00	PK296B1A-SG10	\$261.00
PK296A2A-SG10	\$257.00	PK296B2A-SG10	\$261.00
PK296A1A-SG18	\$257.00	PK296B1A-SG18	\$261.00
PK296A2A-SG18	\$257.00	PK296B2A-SG18	\$261.00
PK296A1A-SG36	\$268.00	PK296B1A-SG36	\$272.00
PK296A2A-SG36	\$268.00	PK296B2A-SG36	\$272.00

◇ **SH Geared Type With Encoder** NEW

● **Bipolar (4 Lead Wires)**

Product Name	List Price
PKP243D15A2-SG3.6-R2FL	\$178.00
PKP243D23A2-SG3.6-R2FL	\$178.00
PKP243D15A2-SG7.2-R2FL	\$178.00
PKP243D23A2-SG7.2-R2FL	\$178.00
PKP243D15A2-SG9-R2FL	\$178.00
PKP243D23A2-SG9-R2FL	\$178.00
PKP243D15A2-SG10-R2FL	\$178.00
PKP243D23A2-SG10-R2FL	\$178.00
PKP243D15A2-SG18-R2FL	\$196.00
PKP243D23A2-SG18-R2FL	\$196.00
PKP243D15A2-SG36-R2FL	\$196.00
PKP243D23A2-SG36-R2FL	\$196.00
PKP264D28A2-SG3.6-R2FL	\$196.00
PKP264D28A2-SG7.2-R2FL	\$196.00
PKP264D28A2-SG9-R2FL	\$196.00
PKP264D28A2-SG10-R2FL	\$196.00
PKP264D28A2-SG18-R2FL	\$212.00
PKP264D28A2-SG36-R2FL	\$212.00

◇ **CS Geared Type** NEW

● **Bipolar (4 Lead Wires)**

Product Name (Single shaft)	List Price	Product Name (Double shaft)	List Price
PKP243D15A2-CS5	\$150.00	PKP243D15B2-CS5	\$152.00
PKP243D23A2-CS5	\$150.00	PKP243D23B2-CS5	\$152.00
PKP243D15A2-CS10	\$150.00	PKP243D15B2-CS10	\$152.00
PKP243D23A2-CS10	\$150.00	PKP243D23B2-CS10	\$152.00
PKP243D15A2-CS15	\$150.00	PKP243D15B2-CS15	\$152.00
PKP243D23A2-CS15	\$150.00	PKP243D23B2-CS15	\$152.00
PKP243D15A2-CS20	\$150.00	PKP243D15B2-CS20	\$152.00
PKP243D23A2-CS20	\$150.00	PKP243D23B2-CS20	\$152.00

● **Connection cable**

Check the product dimensions page for the applicable motors of connection cables.

Recommended drivers and some cables that can be directly connected are available. Refer to page 130.

■ **Included Items**

Type	Included Items	Surge Suppressor	Parallel Key	Motor Installation Screws	Operating Manual
Standard Type High-Resolution Type Flat Type		—	—	—	1 Set
With Electromagnetic Brake		1 Piece	—	—	
SH Geared Type	Frame Size 28 mm Frame Size 42 mm Frame Size 60 mm	—	—	—	
SH Geared Type	Frame Size 90 mm	—	1 Piece	M6×18 P1.0 (4 Screws)	
CS Geared Type	Frame Size 42 mm (1.65 in.)	—	—	—	

■ **Descriptions of Terms in Specifications Tables**

Max. holding torque	: This is the max. holding torque (holding force) the motor has when power is supplied (at rated current) but the motor is not rotating. (With geared types, the value of holding torque considers the permissible strength of the gear.)
Permissible torque	: This is the max. torque which can be applied continuously to the output gear shaft. For the SH Geared Type, make sure that the applied torque, including during acceleration and deceleration, does not exceed the permissible torque.
Max. instantaneous torque	: This is the max. torque that can be applied to the output gear shaft during acceleration/deceleration such when an inertial load is started and stopped.
Holding torque at motor standstill	: This is the holding torque when the automatic current cutback function is active shown.

2-Phase
Motors
PKP

Features
Product
Line

Product
Number
Product Line

Standard
Type

High-
Resolution
Type

Flat Type

SH
Geared
Type

CS
Geared
Type

General
Specifications/
Inner Wiring
Diagram of Motor

5-Phase
Motors
PKP

Features
Product
Line

Product
Number
Product Line

Standard
Type

High-
Resolution
Type

TS
Geared
Type

General
Specifications/
Inner Wiring
Diagram of Motor

Driver for
2-Phase/
5-Phase Motors

Accessories

Standard Type

Frame Size 20 mm (0.79 in.) (Bipolar 4 Lead Wires)

Specifications

Product Name	Maximum Holding Torque N·m (oz·in)	Rotor Inertia J: kg·m ² (oz·in ²)	Rated Current A/Phase	Voltage VDC	Winding Resistance Ω/Phase	Inductance mH/Phase	Basic Step Angle	Recommended Driver Product Name*
PKP213D05□	0.02 (2.8)	1.6×10^{-7} (0.0088)	0.5	4.25	8.5	4.1	1.8°	CVD205BR-K
PKP214D06□	0.036 (5.1)	2.9×10^{-7} (0.0159)	0.6	3.9	6.5	3.5		CVD206BR-K

● The box □ in the product name indicates the shaft **A** (single shaft) or **B** (double shaft).

* See page 94 for details on the recommended drivers.

Speed – Torque Characteristics (Reference Values) fs: Max. Starting Frequency

PKP213D05A/PKP213D05B

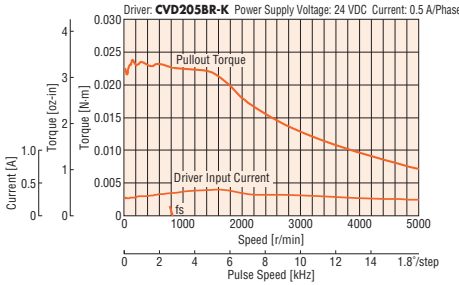

PKP214D06A/PKP214D06B

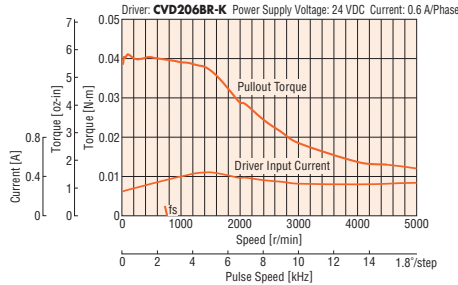

Note

- Data for the speed – torque characteristics is based on Oriental Motor's internal measurement conditions. If the conditions are changed, the characteristics may also change as a result.
- Depending on the driving conditions, a considerable amount of heat may be generated by the motor. Be sure to keep the temperature of the motor case under 100°C (212°F).
- Set the current of the driver so that it does not exceed the rated current of the motor.

Dimensions Unit = mm (in.)

Motor

2D & 3D CAD

Product Name	L1	L2	Mass kg (lb.)	2D CAD
PKP213D05A	30	—	0.05	B976
PKP213D05B	(1.18)	38 (1.50)	(0.110)	
PKP214D06A	40	—	0.07	B978
PKP214D06B	(1.57)	48 (1.89)	(0.154)	

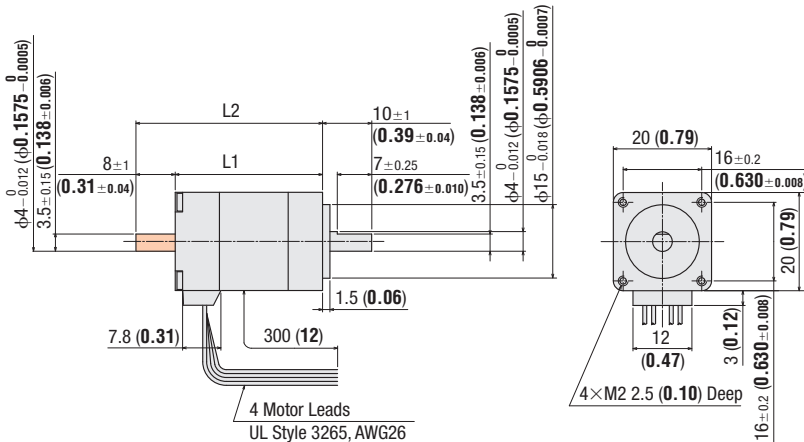

- These dimensions are for double shaft products.
- For single shaft products, ignore the shaded areas.
- Back shaft of double shaft products have a flat the whole length.

Inner Wiring Diagram of Motor

Wiring Diagram No.: Model C5

- Refer to page 67 for inner wiring diagram of motor.

Standard Type with Encoder Frame Size 20 mm (0.79 in.) (Bipolar 4 Lead Wires)

2-Phase Motors
PKP

Specifications

Product Name	Maximum Holding Torque N·m (oz·in)	Rotor Inertia J: kg·m ² (oz·in ²)	Rated Current A/Phase	Voltage VDC	Winding Resistance Ω/Phase	Inductance mH/Phase	Basic Step Angle	Recommended Driver Product Name*
PKP213D05A-R2E ■	0.02 (2.8)	1.66×10^{-7} (0.0091)	0.5	4.25	8.5	4.1	1.8°	CVD205BR-K
PKP214D06A-R2E ■	0.036 (5.1)	2.96×10^{-7} (0.0162)	0.6	3.9	6.5	3.5		CVD206BR-K

- The box ■ in the product name indicates the encoder output circuit type L (line driver output). The voltage output type will have no "■" within the product name.
- See page 64 for encoder specifications.
- * See page 94 for details on the recommended drivers.

Speed – Torque Characteristics (Reference Values) fs: Max. Starting Frequency

PKP213D05A-R2EL
PKP213D05A-R2E

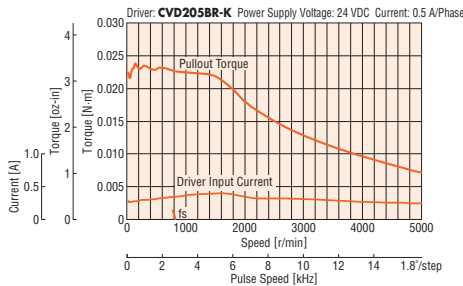

PKP214D06A-R2EL
PKP214D06A-R2E

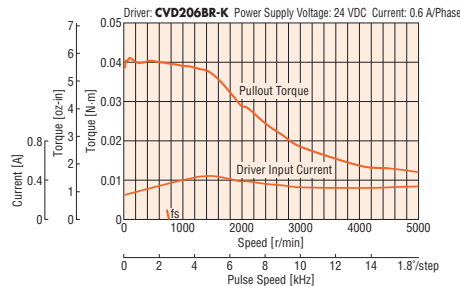

Note

- Data for the speed – torque characteristics is based on Oriental Motor's internal measurement conditions. If the conditions are changed, the characteristics may also change as a result.
- Depending on the driving conditions, a considerable amount of heat may be generated by the motor. To protect the encoder, be sure to keep the motor case temperature at 85°C (185°F) max.
- Set the current of the driver so that it does not exceed the rated current of the motor.

Dimensions Unit = mm (in.)

Motor

2D & 3D CAD

Product Name	L	Mass kg (lb.)	2D CAD
PKP213D05A-R2E ■	46.5 (1.83)	0.06 (0.132)	B1100
PKP214D06A-R2E ■	56.5 (2.22)	0.08 (0.176)	B1101

- The box ■ in the product name indicates the encoder output circuit type L (line driver output). The voltage output type will have no "■" within the product name.

Applicable Connector (Molex)

	Encoder
Connector Housing	51021-0800
Contact	50079-8100
Crimp Tool	57177-5000

Connection Cable (Sold separately)

Encoder Connection Cable

Encoder Output Circuit Type	Product Name	Length L [m (ft.)]
Line Driver Output Type	LCE08A-006	0.6 (2)
Voltage Output Type	LCE05A-006	

•LCE08A-006

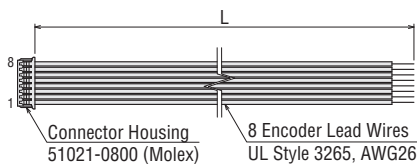

•LCE05A-006

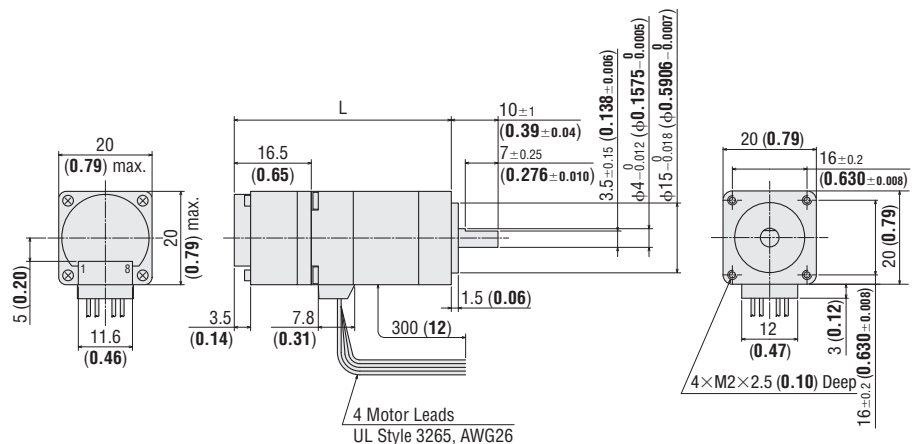
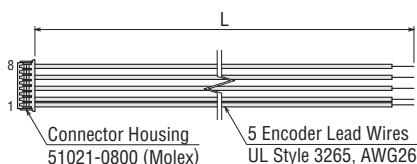

Inner Wiring Diagram of Motor

Wiring Diagram No.: Model C5

- Refer to page 67 for inner wiring diagram of motor.

Features Product Line

Product Number Product Line

Standard Type

High-Resolution Type

Flat Type

SH Geared Type

CS Geared Type

General Specifications/ Inner Wiring Diagram of Motor

5-Phase Motors PKP

Features Product Line

Product Number Product Line

Standard Type

High-Resolution Type

TS Geared Type

General Specifications/ Inner Wiring Diagram of Motor

Driver for 2-Phase/ 5-Phase Motors

Accessories

Standard Type

Frame Size 28 mm (1.10 in.) (Bipolar 4 Lead Wires)

Specifications

Product Name	Maximum Holding Torque N·m (oz·in)	Rotor Inertia J: kg·m ² (oz·in ²)	Rated Current A/Phase	Voltage VDC	Winding Resistance Ω/Phase	Inductance mH/Phase	Basic Step Angle	Recommended Driver Product Name*
PKP223D15□2	0.095 (13.4)	9×10^{-7} (0.049)	1.5	1.77	1.18	0.96	1.8°	CVD215BR-K
PKP225D15□2	0.19 (26)	18×10^{-7} (0.098)		3	2	1.6		

● The box □ in the product name indicates the shaft **A** (single shaft) or **B** (double shaft).

* See page 94 for details on the recommended drivers.

Speed – Torque Characteristics (Reference Values) fs: Max. Starting Frequency

PKP223D15A2/ PKP223D15B2

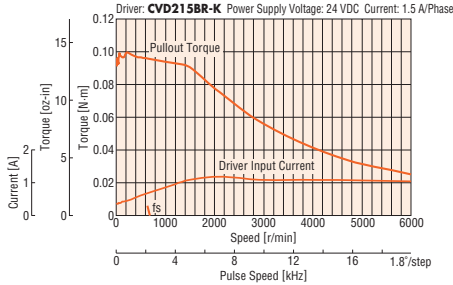

PKP225D15A2/ PKP225D15B2

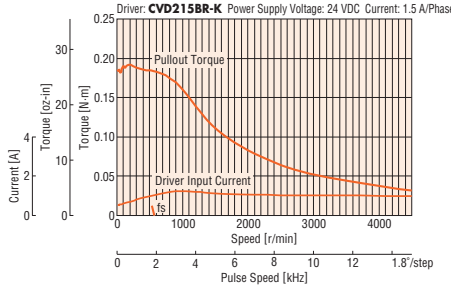

Note

- Data for the speed – torque characteristics is based on Oriental Motor's internal measurement conditions. If the conditions are changed, the characteristics may also change as a result.
- Depending on the driving conditions, a considerable amount of heat may be generated by the motor. Be sure to keep the temperature of the motor case under 100°C (212°F).
- Set the current of the driver so that it does not exceed the rated current of the motor.

Dimensions Unit = mm (in.)

Motor

2D & 3D CAD

Product Name	L1	L2	Mass kg (lb.)	2D CAD
PKP223D15A2	32	—	0.11 (0.24)	B980
PKP223D15B2	(1.26)	42 (1.65)		
PKP225D15A2	51.5	—	0.2 (0.44)	B982
PKP225D15B2	(2.03)	61.5 (2.42)		

Applicable Connector

Connector Housing: 51065-0600 (Molex)

Contact: 50212-8100 (Molex)

Crimp Tool: 57176-5000 (Molex)

Inner Wiring Diagram of Motor

Wiring Diagram No.: Model B③

- Refer to page 67 for inner wiring diagram of motor.

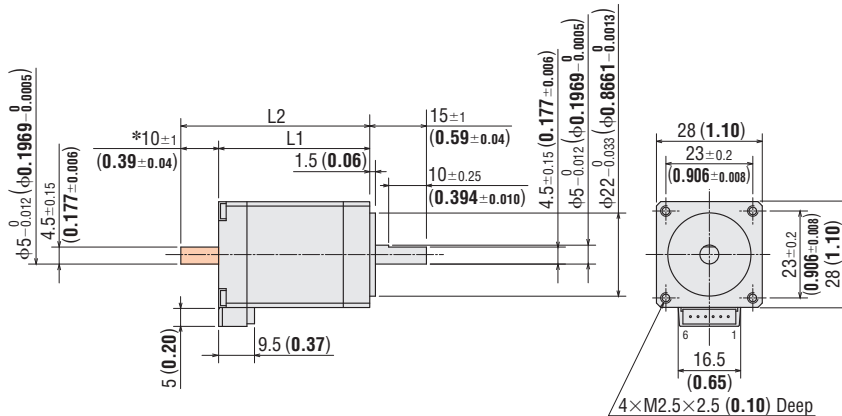

*The length of the shaft flat on the double shaft model is 10±0.25 (0.394±0.010).

● These dimensions are for double shaft motors.

For single shaft motors, ignore the shaded areas.

Connection Cable (Sold separately)

Motor Connection Cable

Product Name	Length L [m (ft.)]
LC2B06A	0.6 (2)
LC2B10A	1 (3.3)

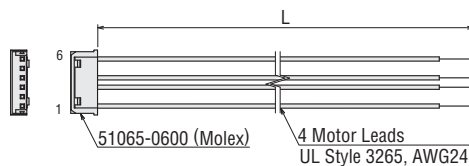

Standard Type with Encoder Frame Size 28 mm (1.10 in.) (Bipolar 4 Lead Wires)

2-Phase Motors PKP

Specifications

Product Name	Maximum Holding Torque N·m (oz·in)	Rotor Inertia J: kg·m ² (oz·in ²)	Rated Current A/Phase	Voltage VDC	Winding Resistance Ω/Phase	Inductance mH/Phase	Basic Step Angle	Recommended Driver Product Name*
PKP223D15A2-R2□■	0.095 (13.4)	9.1×10^{-7} (0.05)	1.5	1.77	1.18	0.96	1.8°	CVD215BR-K
PKP225D15A2-R2□■	0.19 (26)	18×10^{-7} (0.098)		3	2	1.6		

● Either **E** (200P/R) or **F** (400P/R) indicating the encoder resolution is entered where the box □ is located within the product name.

A code **L** (line driver output) indicating the encoder output circuit type is entered where the box ■ is located within the product name. The voltage output type will have no "■" in the product name.

● See page 64 for encoder specifications.

*See page 94 for details on the recommended drivers.

Speed – Torque Characteristics (Reference Values) fs: Max. Starting Frequency

PKP223D15A2-R2EL/ PKP223D15A2-R2FL
PKP223D15A2-R2E/ PKP223D15A2-R2F

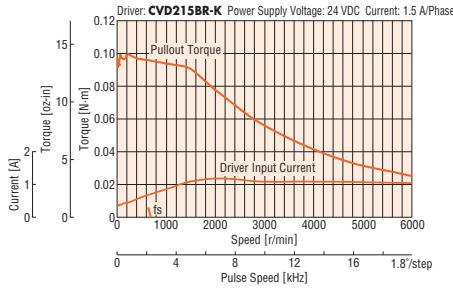

PKP225D15A2-R2EL/ PKP225D15A2-R2FL
PKP225D15A2-R2E/ PKP225D15A2-R2F

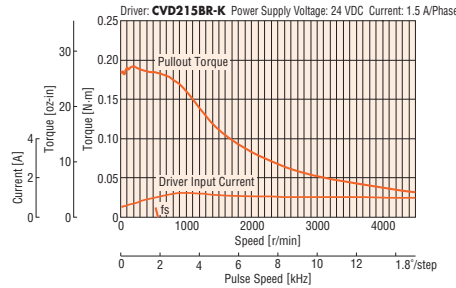

Note

- Data for the speed – torque characteristics is based on Oriental Motor's internal measurement conditions. If the conditions are changed, the characteristics may also change as a result.
- Depending on the driving conditions, a considerable amount of heat may be generated by the motor. To protect the encoder, keep the motor case temperature at 85°C (185°F) max.
- Set the current of the driver so that it does not exceed the rated current of the motor.

Dimensions Unit = mm (in.)

Motor

2D & 3D CAD

Product Name	L	Mass kg (lb.)	2D CAD
PKP223D15A2-R2□■	47.5 (1.87)	0.12 (0.26)	B1198
PKP225D15A2-R2□■	67 (2.64)	0.21 (0.46)	B1199

● Either **E** (200P/R) or **F** (400P/R) indicating the encoder resolution is entered where the box □ is located within the product name.

A code **L** (line driver output) indicating the encoder output circuit type is entered where the box ■ is located within the product name. The voltage output type will have no "■" in the product name.

● Applicable Connector (Molex)

	Motor	Encoder
Connector Housing	51065-0600	51021-0800
Contact	50212-8100	50079-8100
Crimp Tool	57176-5000	57177-5000

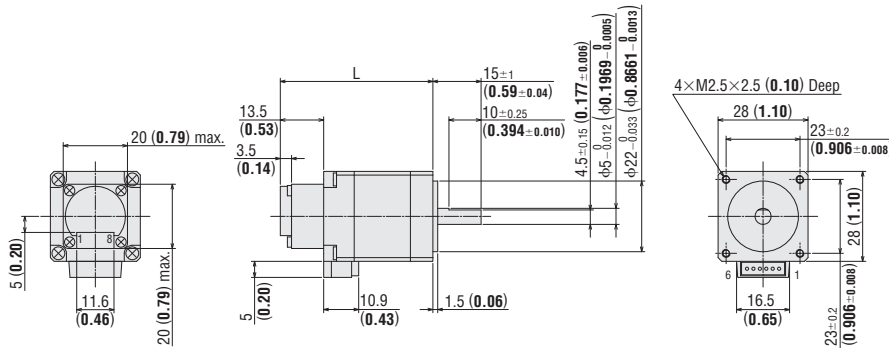

Inner Wiring Diagram of Motor

Wiring Diagram No.: Model B③

● Refer to page 67 for inner wiring diagram of motor.

Connection Cable (Sold separately)

Motor Connection Cable

Product Name	Length L [m (ft.)]
LC2B06A	0.6 (2)
LC2B10A	1 (3.3)

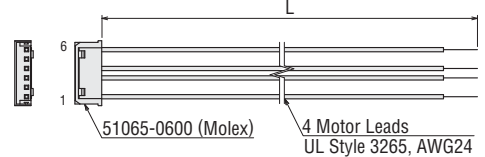

Encoder Connection Cable

Encoder Output Circuit Type	Product Name	Length L [m (ft.)]
Line Driver Output Type	LCE08A-006	0.6 (2)
Voltage Output Type	LCE05A-006	

•LCE08A-006

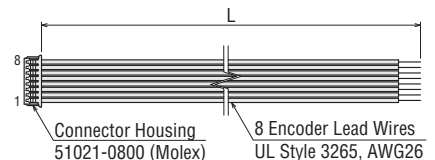

•LCE05A-006

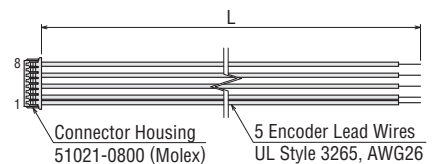

Features Product Line

Product Number Product Line

Standard Type

High-Resolution Type

Flat Type

SH Geared Type

CS Geared Type

General Specifications/ Inner Wiring Diagram of Motor

5-Phase Motors PKP

Features Product Line

Product Number Product Line

Standard Type

High-Resolution Type

TS Geared Type

General Specifications/ Inner Wiring Diagram of Motor

Driver for 2-Phase/ 5-Phase Motors

Accessories

Motor Frame Size

- 20 mm (0.79 in.)
- 28 mm (1.10 in.)
- 35 mm (1.38 in.)
- 42 mm (1.65 in.)
- 50 mm (1.97 in.)
- 51 mm (2.01 in.)
- 56.4 mm (2.22 in.)
- 60 mm (2.36 in.)
- 61 mm (2.40 in.)
- 85 mm (3.35 in.)

Standard Type with Electromagnetic Brake Frame Size 28 mm (1.10 in.) (Bipolar 4 Lead Wires)

Specifications

Product Name	Maximum Holding Torque N·m (oz·in)	Rotor Inertia J: kg·m ² (oz·in ²)	Rated Current A/Phase	Voltage VDC	Winding Resistance Ω/Phase	Inductance mH/Phase	Basic Step Angle	Electromagnetic Brake Static Friction Torque N·m (oz·in)
PKP223D15M2	0.095 (13.4)	14×10^{-7} (0.077)*	1.5	1.77	1.18	0.96	1.8°	0.08 (11.3)
PKP225D15M2	0.19 (26)	23×10^{-7} (0.126)*		3	2	1.6		

● See page 64 for electromagnetic brake specifications.
 *The inertia of the electromagnetic brake is included in the value.

Speed – Torque Characteristics (Reference Values) fs: Max. Starting Frequency

PKP223D15M2

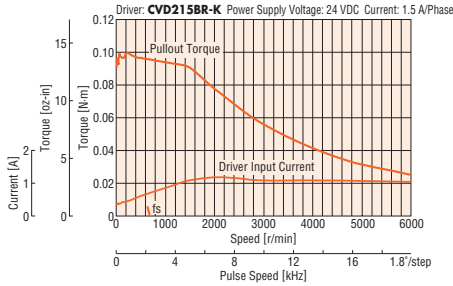

PKP225D15M2

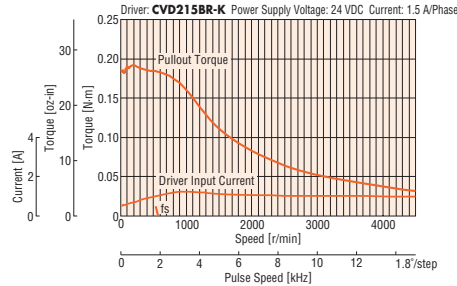

Note

- Data for the speed – torque characteristics is based on Oriental Motor's internal measurement conditions. If the conditions are changed, the characteristics may also change as a result.
- Depending on the driving conditions, a considerable amount of heat may be generated by the motor. Be sure to keep the temperature of the motor case under 100°C (212°F).
- Set the current of the driver so that it does not exceed the rated current of the motor.

Dimensions Unit = mm (in.)

● Motor

2D & 3D CAD

Product Name	L	Mass kg (lb.)	2D CAD
PKP223D15M2	65.5 (2.58)	0.17 (0.37)	B1196
PKP225D15M2	85 (3.35)	0.26 (0.57)	B1197

- Applicable Connector
 Connector Housing: 51065-0600 (Molex)
 Contact: 50212-8100 (Molex)
 Crimp Tool: 57176-5000 (Molex)

Inner Wiring Diagram of Motor

Wiring Diagram No.: Model B③

- Refer to page 67 for inner wiring diagram of motor.

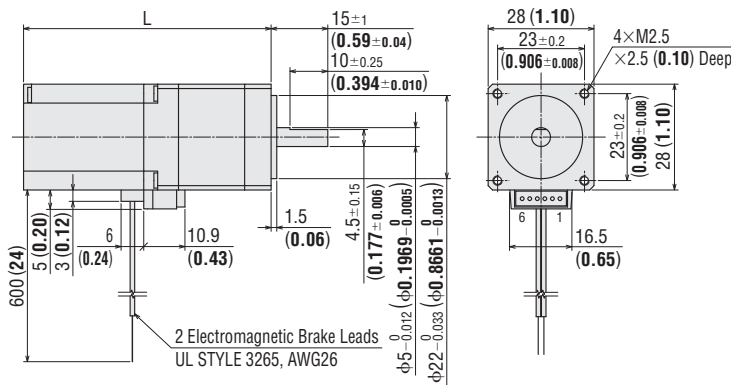

● Connection Cable (Sold separately)

◇ Motor Connection Cable

Product Name	Length L [m (ft.)]
LC2B06A	0.6 (2)
LC2B10A	1 (3.3)

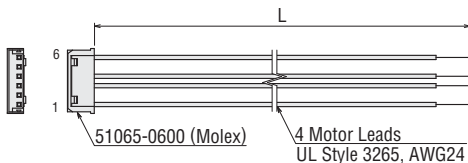

Standard Type

Frame Size 35 mm (1.38 in.) (Bipolar 4 Lead Wires)

2-Phase Motors
PKP

Specifications

Product Name	Maximum Holding Torque N-m (oz-in)	Rotor Inertia J: kg·m ² (oz-in ²)	Rated Current A/Phase	Voltage VDC	Winding Resistance Ω/Phase	Inductance mH/Phase	Basic Step Angle	Recommended Driver Product Name*
PKP233D15□	0.2 (28)	24×10 ⁻⁷ (0.131)	1.5	2.43	1.62	1.5	1.8°	CVD215BR-K
PKP233D23□			2.3	1.56	0.68	0.67		CVD223BR-K
PKP235D15□	0.37 (52)	50×10 ⁻⁷ (0.27)	1.5	3.6	2.4	2.6		CVD215BR-K
PKP235D23□			2.3	2.23	0.97	1.2		CVD223BR-K

□ The box □ in the product name indicates the shaft **A** (single shaft) or **B** (double shaft).

*See page 94 for details on the recommended drivers.

Speed – Torque Characteristics (Reference Values) *f_s*: Max. Starting Frequency

PKP233D15A/PKP233D15B

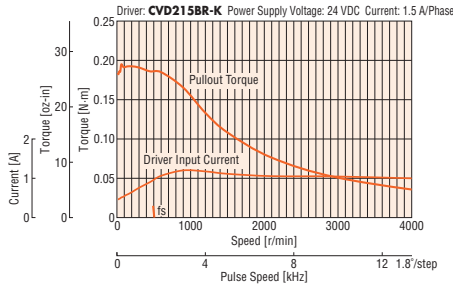

PKP235D15A/PKP235D15B

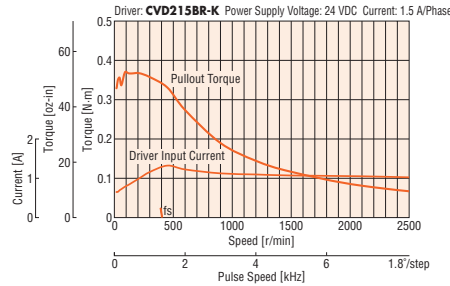

PKP233D23A/PKP233D23B

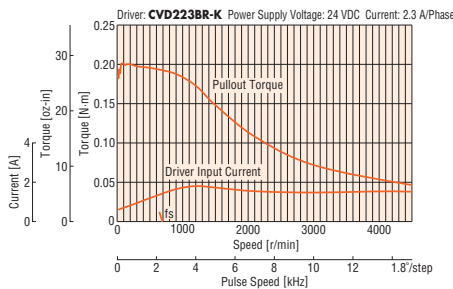

PKP235D23A/PKP235D23B

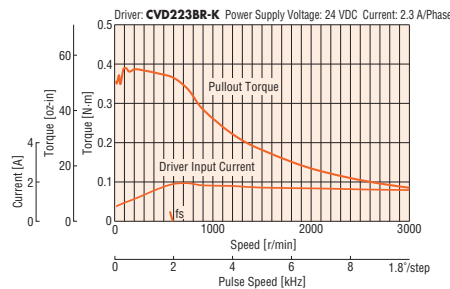

Note

- Data for the speed – torque characteristics is based on Oriental Motor's internal measurement conditions. If the conditions are changed, the characteristics may also change as a result.
- Depending on the driving conditions, a considerable amount of heat may be generated by the motor. Be sure to keep the temperature of the motor case under 100°C (212°F).
- Set the current of the driver so that it does not exceed the rated current of the motor.

Dimensions Unit = mm (in.)

Motor

2D & 3D CAD

Product Name	L1	L2	Mass kg (lb.)	2D CAD
PKP233D15A	37 (1.46)	—	0.18 (0.4)	B983
PKP233D15B		52 (2.05)		
PKP233D23A	52 (2.05)	—	0.285 (0.63)	B1111
PKP233D23B		52 (2.05)		
PKP235D15A	52 (2.05)	—	0.285 (0.63)	B984
PKP235D15B		67 (2.67)		
PKP235D23A	52 (2.05)	—	0.285 (0.63)	B1112
PKP235D23B		67 (2.67)		

Applicable Connector

Connector Housing: 51103-0600 (Molex)
Contact: 50351-8100 (Molex)
Crimp Tool: 57295-5000 (Molex)

Connection Cable (Sold separately)

Motor Connection Cable

Product Name	Length L [m (ft.)]
LC2B06B	0.6 (2)
LC2B10B	1 (3.3)

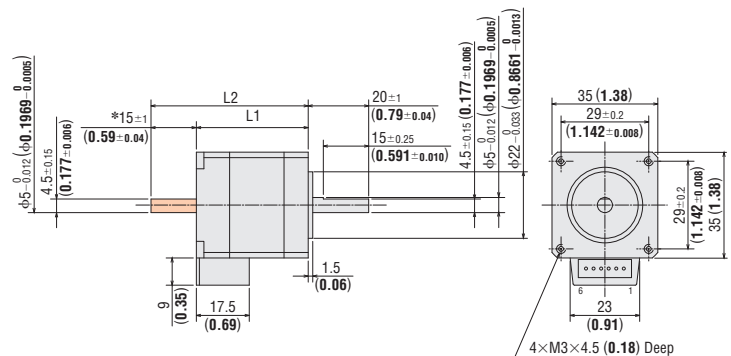
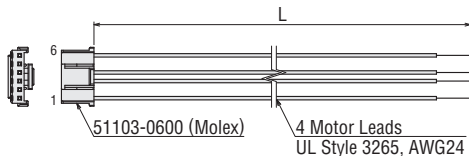

*The length of machining on the double shaft product is 15±0.25 (0.591±0.010).

● These dimensions are for double shaft products.

For single shaft products, ignore the shaded areas.

Inner Wiring Diagram of Motor

Wiring Diagram No.: Model B③

● Refer to page 67 for inner wiring diagram of motor.

Features Product Line

Product Number Product Line

Standard Type

High-Resolution Type

Flat Type

SH Geared Type

CS Geared Type

General Specifications/ Inner Wiring Diagram of Motor

5-Phase Motors PKP

Features Product Line

Product Number Product Line

Standard Type

High-Resolution Type

TS Geared Type

General Specifications/ Inner Wiring Diagram of Motor

Driver for 2-Phase/ 5-Phase Motors

Accessories

Standard Type with Encoder Frame Size 35 mm (1.38 in.) (Bipolar 4 Lead Wires)

20 mm
(0.79 in.)

28 mm
(1.10 in.)

35 mm
(1.38 in.)

42 mm
(1.65 in.)

50 mm
(1.97 in.)
51 mm
(2.01 in.)

56.4 mm
(2.22 in.)

60 mm
(2.36 in.)
61 mm
(2.40 in.)

85 mm
(3.35 in.)

Specifications

Product Name	Maximum Holding Torque N·m (oz·in)	Rotor Inertia J: kg·m ² (oz·in ²)	Rated Current A/Phase	Voltage VDC	Winding Resistance Ω/Phase	Inductance mH/Phase	Basic Step Angle	Recommended Driver Product Name*
PKP233D15A-R2	0.2 (28)	24 × 10 ⁻⁷ (0.131)	1.5	2.43	1.62	1.5	1.8°	CVD215BR-K
PKP233D23A-R2			2.3	1.56	0.68	0.67		CVD223BR-K
PKP235D15A-R2	0.37 (52)	50 × 10 ⁻⁷ (0.27)	1.5	3.6	2.4	2.6		CVD215BR-K
PKP235D23A-R2			2.3	2.23	0.97	1.2		CVD223BR-K

- Either **E** (200P/R) or **F** (400P/R) indicating the encoder resolution is entered where the box □ is located within the product name.
- A code **L** (line driver output) indicating the encoder output circuit type is entered where the box ■ is located within the product name. The voltage output type will have no " ■ " in the product name.
- See page 64 for encoder specifications.
- *See page 94 for details on the recommended drivers.

Speed – Torque Characteristics (Reference Values) fs: Max. Starting Frequency

PKP233D15A-R2EL/PKP233D15A-R2FL
PKP233D15A-R2E/PKP233D15A-R2F

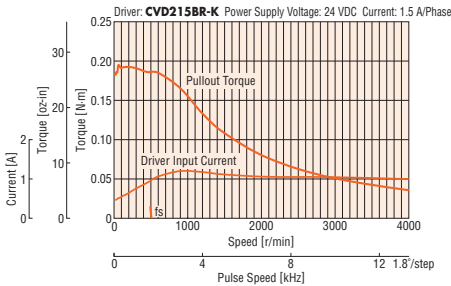

PKP235D15A-R2EL/PKP235D15A-R2FL
PKP235D15A-R2E/PKP235D15A-R2F

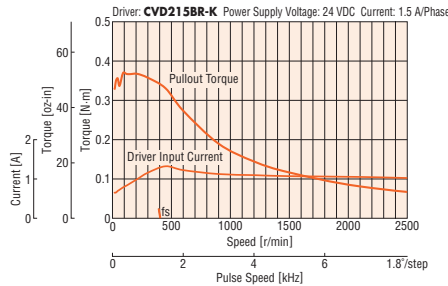

PKP233D23A-R2EL/PKP233D23A-R2FL
PKP233D23A-R2E/PKP233D23A-R2F

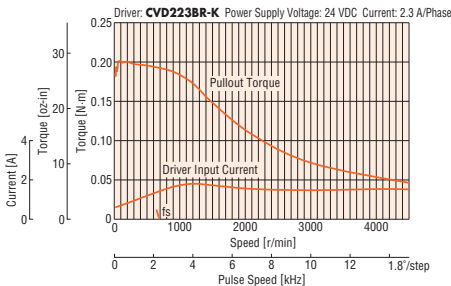

PKP235D23A-R2EL/PKP235D23A-R2FL
PKP235D23A-R2E/PKP235D23A-R2F

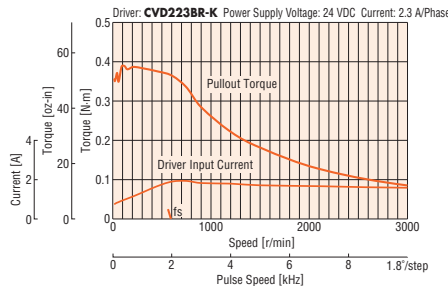

Note

- Data for the speed – torque characteristics is based on Oriental Motor's internal measurement conditions. If the conditions are changed, the characteristics may also change as a result.
- Depending on the driving conditions, a considerable amount of heat may be generated by the motor. To protect the encoder, keep the motor case temperature at 85°C (185°F) max.
- Set the current of the driver so that it does not exceed the rated current of the motor.

Dimensions Unit = mm (in.)

Motor

2D & 3D CAD

Product Name	L	Mass kg (lb.)	2D CAD
PKP233D15A-R2 <input type="checkbox"/> <input type="checkbox"/>	50.5 (1.99)	0.19 (0.42)	B1102
PKP233D23A-R2 <input type="checkbox"/> <input type="checkbox"/>			
PKP235D15A-R2 <input type="checkbox"/> <input type="checkbox"/>	65.5 (2.58)	0.295 (0.65)	B1103
PKP235D23A-R2 <input type="checkbox"/> <input type="checkbox"/>			

● Either **E** (200P/R) or **F** (400P/R) indicating the encoder resolution is entered where the box is located within the product name.

A code **L** (line driver output) indicating the encoder output circuit type is entered where the box is located within the product name. The voltage output type will have no " " in the product name.

● Applicable Connector (Molex)

	Motor	Encoder
Connector Housing	51103-0600	51021-0800
Contact	50351-8100	50079-8100
Crimp Tool	57295-5000	57177-5000

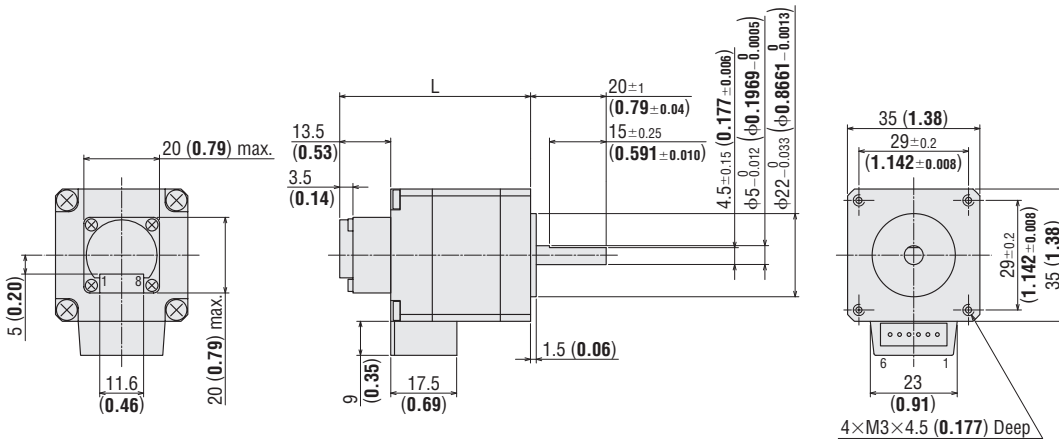

● Connection Cables (Sold separately)

◇ Motor Connection Cable

Product Name	Length L [m (ft.)]
LC2B06B	0.6 (2)
LC2B10B	1 (3.3)

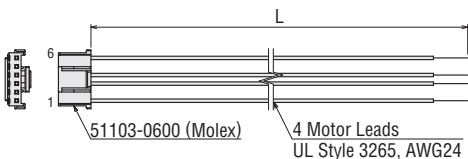

◇ Encoder Connection Cable

Encoder Output Circuit Type	Product Name	Length L [m (ft.)]
Line Driver Output Type	LCE08A-006	0.6 (2)
Voltage Output Type	LCE05A-006	

● LCE08A-006

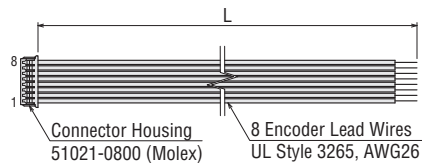

● LCE05A-006

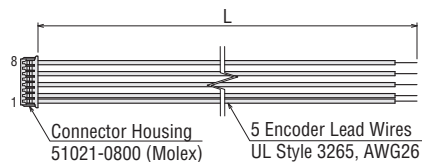

Inner Wiring Diagram of Motor

Wiring Diagram No.: Model B③

● Refer to page 67 for inner wiring diagram of motor.

Standard Type with Electromagnetic Brake Frame Size 35 mm (1.38 in.) (Bipolar 4 Lead Wires)

20 mm
(0.79 in.)

28 mm
(1.10 in.)

35 mm
(1.38 in.)

42 mm
(1.65 in.)

50 mm
(1.97 in.)
51 mm
(2.01 in.)

56.4 mm
(2.22 in.)

60 mm
(2.36 in.)
61 mm
(2.40 in.)

85 mm
(3.35 in.)

Specifications

Product Name	Maximum Holding Torque N·m (oz·in)	Rotor Inertia J: kg·m ² (oz·in ²)	Rated Current A/Phase	Voltage VDC	Winding Resistance Ω/Phase	Inductance mH/Phase	Basic Step Angle	Electricmagnetic Brake Static Friction Torque N·m (oz·in)
PKP233D15M	0.2 (28)	36×10^{-7} (0.197)*	1.5	2.43	1.62	1.5	1.8°	0.3 (42)
PKP235D15M	0.37 (52)	62×10^{-7} (0.34)*		3.6	2.4	2.6		

● See page 64 for electromagnetic brake specifications.

*The Inertia of the electromagnetic brake is included in the value.

Speed – Torque Characteristics (Reference Values) *fs*: Max. Starting Frequency

PKP233D15M

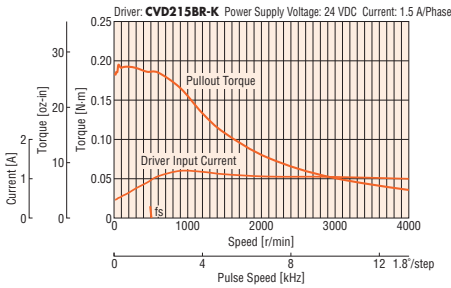

PKP235D15M

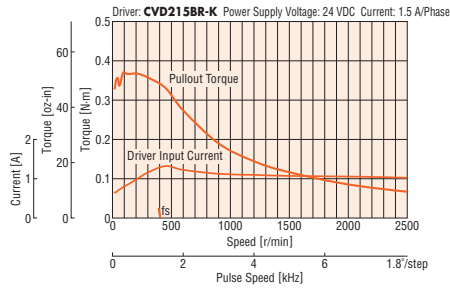

Note

- Data for the speed – torque characteristics is based on Oriental Motor's internal measurement conditions. If the conditions are changed, the characteristics may also change as a result.
- Depending on the driving conditions, a considerable amount of heat may be generated by the motor. Be sure to keep the temperature of the motor case under 100°C (212°F).
- Set the current of the driver so that it does not exceed the rated current of the motor.

Dimensions Unit: mm (in.)

Motor

2D & 3D CAD

Product Name	L	Mass kg (lb.)	2D CAD
PKP233D15M	71 (2.80)	0.285 (0.63)	B1134
PKP235D15M	86 (3.39)	0.39 (0.86)	B1135

- Applicable Connector (Molex)
Connector Housing: 51103-0600
Contact: 50351-8100
Crimp Tool: 57295-5000

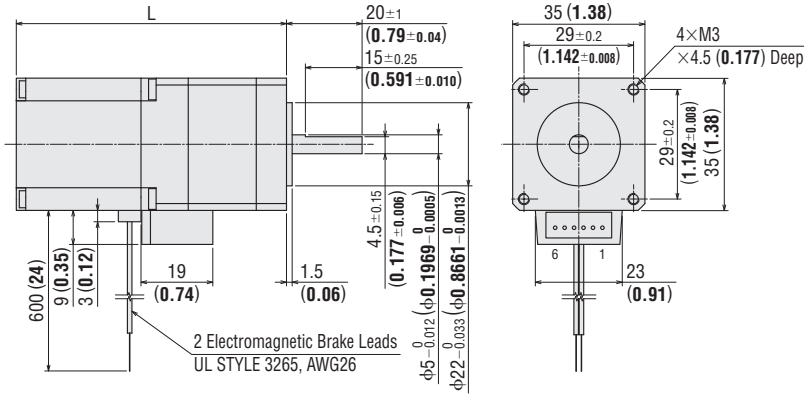

Connection Cables (Sold separately)

Motor Connection Cable

Product Name	Length L [m (ft.)]
LC2B06B	0.6 (2)
LC2B10B	1 (3.3)

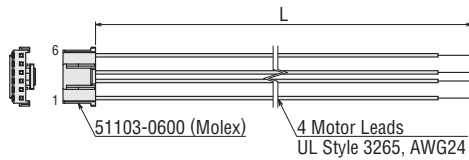

Inner Wiring Diagram of Motor

Wiring Diagram No.: Model B③

- Refer to page 67 for inner wiring diagram of motor.

2-Phase
Motors
PKP

Features
Product
Line

Product
Number
Product Line

Standard
Type

High-
Resolution
Type

Flat Type

SH
Geared
Type

CS
Geared
Type

General
Specifications/
Inner Wiring
Diagram of Motor

5-Phase
Motors
PKP

Features
Product
Line

Product
Number
Product Line

Standard
Type

High-
Resolution
Type

TS
Geared
Type

General
Specifications/
Inner Wiring
Diagram of Motor

Driver for
2-Phase/
5-Phase Motors

Accessories

Standard Type

Frame Size 42 mm (1.65 in.) (Bipolar 4 Lead Wires)

Specifications

Product Name	Maximum Holding Torque N·m (oz·in)	Rotor Inertia J: kg·m ² (oz·in ²)	Rated Current A/Phase	Voltage VDC	Winding Resistance Ω/Phase	Inductance mH/Phase	Basic Step Angle	Recommended Driver Product Name*
PKP243D08□2	0.35 (49)	36 × 10 ⁻⁷ (0.197)	0.85	4.6	5.4	10	1.8°	CVD223FBR-K
PKP243D15□2			1.5	2.7	1.8	3.3		
PKP243D23□2			2.3	1.8	0.78	1.4		
PKP244D08□2	0.48 (68)	54 × 10 ⁻⁷ (0.3)	0.85	5.7	6.7	14		
PKP244D15□2			1.5	3.2	2.1	4.4		
PKP244D23□2			2.3	2.1	0.93	1.9		
PKP245D08□2	0.66 (93)	73 × 10 ⁻⁷ (0.4)	0.85	6	7.1	16		
PKP245D15□2			1.5	3.3	2.2	5.3		
PKP245D23□2			2.3	2.3	1	2.2		
PKP246D15□2	0.99 (140)	110 × 10 ⁻⁷ (0.6)	1.5	4.4	2.9	7.9		
PKP246D23□2			2.3	3.2	1.4	3.3		

● The box □ in the product name indicates the shaft **A** (single shaft) or **B** (double shaft).

*See page 94 for details on the recommended drivers.

Speed – Torque Characteristics (Reference Values) fs: Max. Starting Frequency

PKP243D08A2/ PKP243D08B2

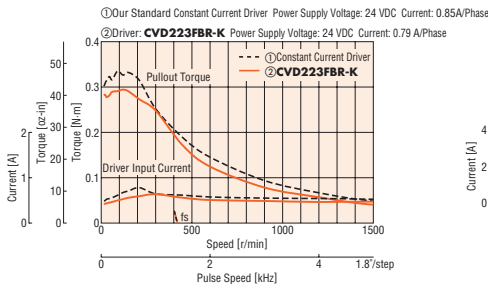

PKP243D15A2/ PKP243D15B2

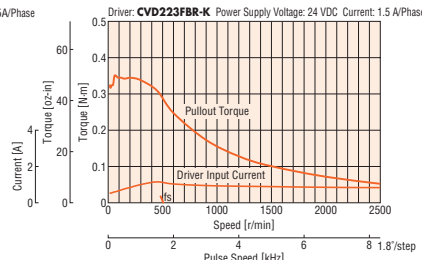

PKP243D23A2/ PKP243D23B2

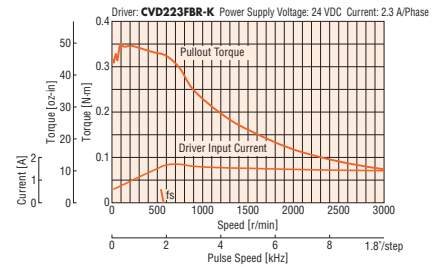

PKP244D08A2/ PKP244D08B2

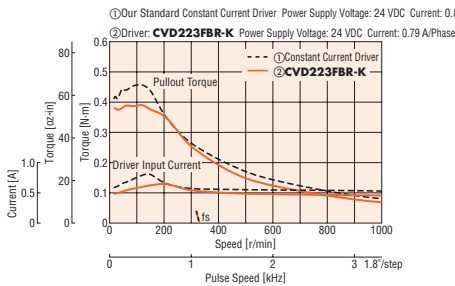

PKP244D15A2/ PKP244D15B2

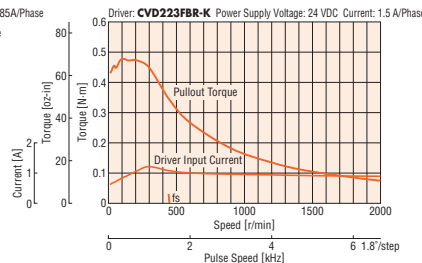

PKP244D23A2/ PKP244D23B2

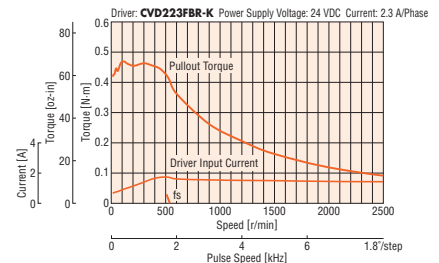

PKP245D08A2/ PKP245D08B2

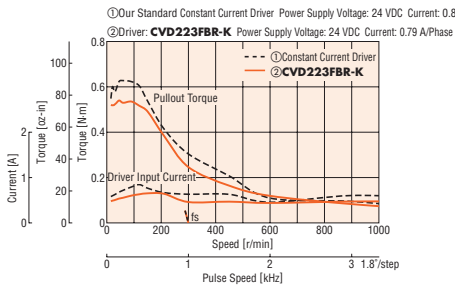

PKP245D15A2/ PKP245D15B2

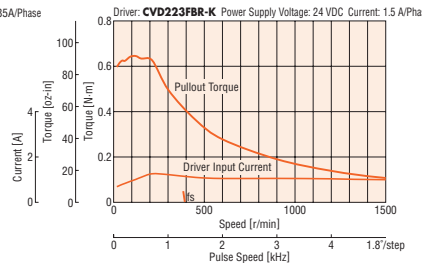

PKP245D23A2/ PKP245D23B2

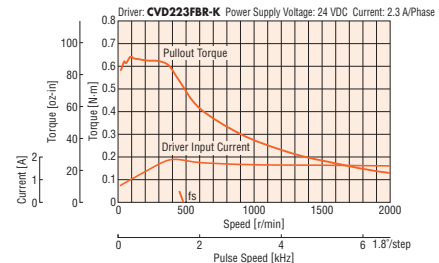

PKP246D15A2/ PKP246D15B2

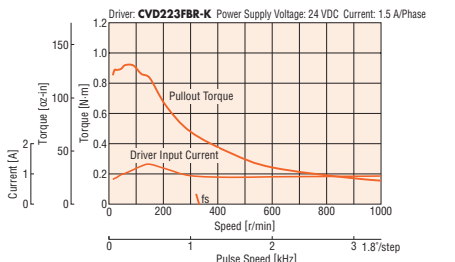

PKP246D23A2/ PKP246D23B2

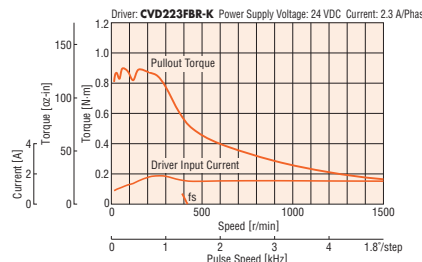

Note

- Data for the speed – torque characteristics is based on Oriental Motor's internal measurement conditions. If the conditions are changed, the characteristics may also change as a result.
- Depending on the driving conditions, a considerable amount of heat may be generated by the motor. Be sure to keep the temperature of the motor case under 100°C (212°F).
- Set the current of the driver so that it does not exceed the rated current of the motor.

Dimensions Unit: mm (in.)

● Motor

2D & 3D CAD

Product Name	L1	L2	Mass kg (lb.)	2D CAD
PKP243D08A2	33 (1.30)	—	0.23 (0.51)	B1260
PKP243D08B2		48 (1.89)		
PKP243D15A2		—		
PKP243D15B2		48 (1.89)		
PKP243D23A2		—		
PKP243D23B2	48 (1.89)	—	—	—
PKP244D08A2	39 (1.54)	—	0.3 (0.66)	B1261
PKP244D08B2		54 (2.13)		
PKP244D15A2		—		
PKP244D15B2		54 (2.13)		
PKP244D23A2		—		
PKP244D23B2	54 (2.13)	—	—	—
PKP245D08A2	47 (1.85)	—	0.37 (0.81)	B1262
PKP245D08B2		62 (2.44)		
PKP245D15A2		—		
PKP245D15B2		62 (2.44)		
PKP245D23A2		—		
PKP245D23B2	62 (2.44)	—	—	—
PKP246D15A2	59 (2.32)	—	0.5 (1.1)	B1263
PKP246D15B2		74 (2.91)		
PKP246D23A2		—		
PKP246D23B2		74 (2.91)		

● Applicable Connector

Connector Housing: MDF97-5S-3.5C (HIROSE ELECTRIC CO., LTD.)
 Contact: MDF97-22SC (HIROSE ELECTRIC CO., LTD.)
 Crimp Tool: HT801/MDF97-22S (HIROSE ELECTRIC CO., LTD.)

● Connection Cables (Sold separately)

◇ Motor Connection Cable

Product Name	Length L [m (ft.)]
LC2B06E	0.6 (2)
LC2B10E	1 (3.3)

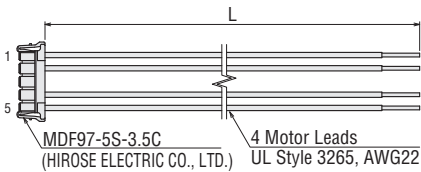

Inner Wiring Diagram of Motor

Wiring Diagram No.: Model A①

● Refer to page 67 for inner wiring diagram of motor.

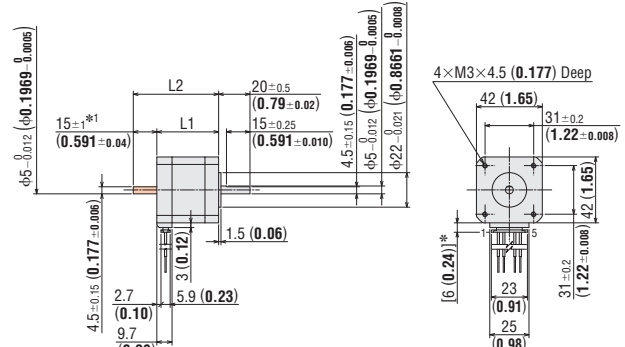

*1 The length of machining on the double shaft product is 15 ± 0.25 (0.591 ± 0.010).

*2 With connection cable

● These dimensions are for double shaft products. For single shaft products, ignore the areas.

2-Phase
Motors
PKP

Features
Product
Line

Product
Number
Product Line

Standard
Type

High-
Resolution
Type

Flat Type

SH
Geared
Type

CS
Geared
Type

General
Specifications/
Inner Wiring
Diagram of Motor

5-Phase
Motors
PKP

Features
Product
Line

Product
Number
Product Line

Standard
Type

High-
Resolution
Type

TS
Geared
Type

General
Specifications/
Inner Wiring
Diagram of Motor

Driver for
2-Phase/
5-Phase Motors

Accessories

Standard Type with Encoder Frame Size 42 mm (1.65 in.) (Bipolar 4 Lead Wires)

20 mm
(0.79 in.)

28 mm
(1.10 in.)

35 mm
(1.38 in.)

42 mm
(1.65 in.)

50 mm
(1.97 in.)
51 mm
(2.01 in.)

56.4 mm
(2.22 in.)

60 mm
(2.36 in.)
61 mm
(2.40 in.)

85 mm
(3.35 in.)

Specifications

Product Name	Maximum Holding Torque N·m (oz·in)	Rotor Inertia J: kg·m ² (oz·in ²)	Rated Current A/Phase	Voltage VDC	Winding Resistance Ω/Phase	Inductance mH/Phase	Basic Step Angle	Recommended Driver Product Name*
PKP243D08A2-R2	0.35 (49)	36 × 10 ⁻⁷ (0.197)	0.85	4.5	5.4	10	1.8°	CVD223FBR-K
PKP243D15A2-R2			1.5	2.7	1.8	3.3		
PKP243D23A2-R2			2.3	1.8	0.78	1.4		
PKP244D08A2-R2	0.48 (68)	54 × 10 ⁻⁷ (0.3)	0.85	5.7	6.7	14		
PKP244D15A2-R2			1.5	3.2	2.1	4.4		
PKP244D23A2-R2			2.3	2.1	0.93	1.9		
PKP245D08A2-R2	0.66 (93)	73 × 10 ⁻⁷ (0.4)	0.85	6	7.1	16		
PKP245D15A2-R2			1.5	3.3	2.2	5.3		
PKP245D23A2-R2			2.3	2.3	1	2.2		
PKP246D15A2-R2	0.99 (140)	110 × 10 ⁻⁷ (0.6)	1.5	4.4	2.9	7.9		
PKP246D23A2-R2			2.3	3.2	1.4	3.3		

● The box **E** in the product name indicates the encoder resolution **E** (200 P/R) or **F** (400 P/R).

● The box **L** in the product name indicates the encoder output circuit type **L** (line driver output). The voltage output type will have no " **L** " in the product name.

● See page 64 for encoder specifications.

*See page 94 for details on the recommended drivers.

Speed – Torque Characteristics (Reference Values) *fs*: Max. Starting Frequency

PKP243D08A2-R2EL/ PKP243D08A2-R2FL
PKP243D08A2-R2E/ PKP243D08A2-R2F

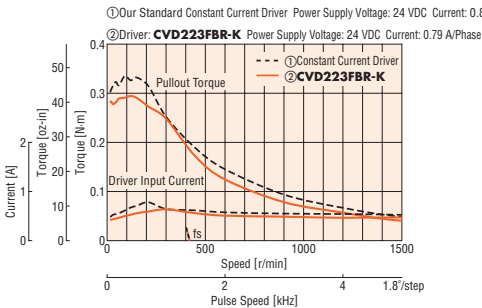

PKP243D15A2-R2EL/ PKP243D15A2-R2FL
PKP243D15A2-R2E/ PKP243D15A2-R2F

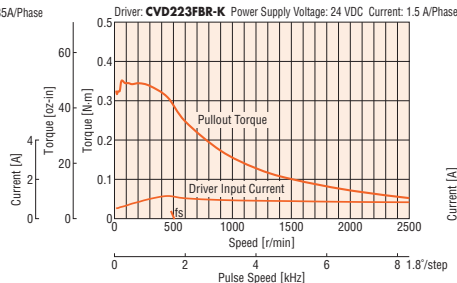

PKP243D23A2-R2EL/ PKP243D23A2-R2FL
PKP243D23A2-R2E/ PKP243D23A2-R2F

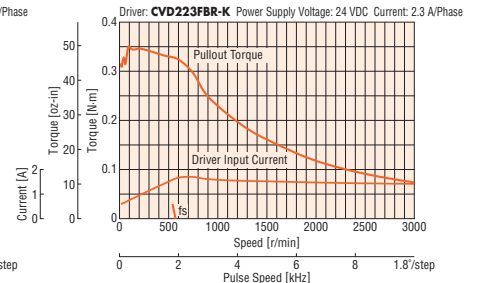

PKP244D08A2-R2EL/ PKP244D08A2-R2FL
PKP244D08A2-R2E/ PKP244D08A2-R2F

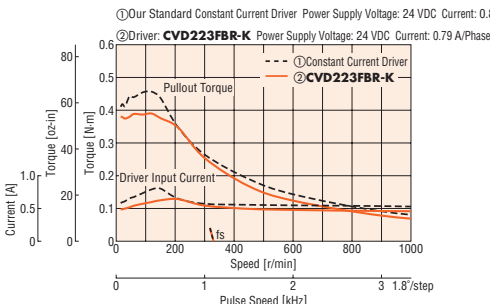

PKP244D15A2-R2EL/ PKP244D15A2-R2FL
PKP244D15A2-R2E/ PKP244D15A2-R2F

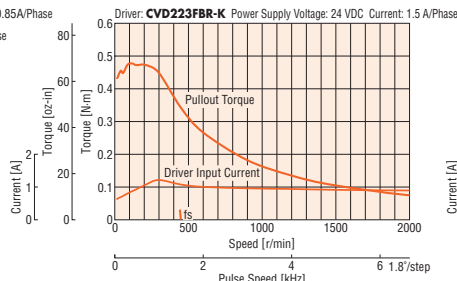

PKP244D23A2-R2EL/ PKP244D23A2-R2FL
PKP244D23A2-R2E/ PKP244D23A2-R2F

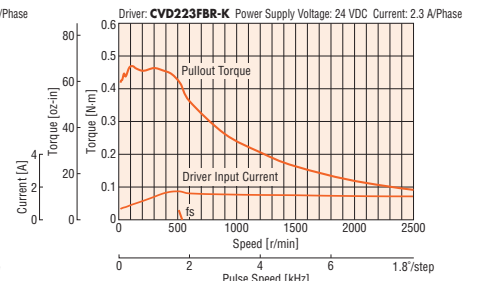

PKP245D08A2-R2EL/ PKP245D08A2-R2FL
PKP245D08A2-R2E/ PKP245D08A2-R2F

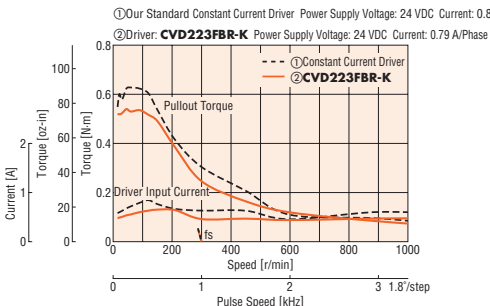

PKP245D15A2-R2EL/ PKP245D15A2-R2FL
PKP245D15A2-R2E/ PKP245D15A2-R2F

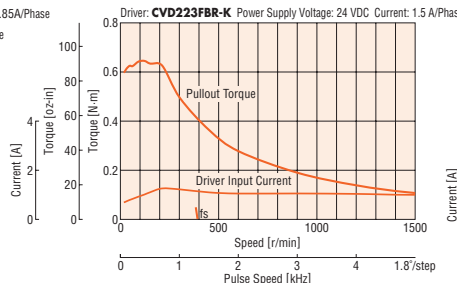

PKP245D23A2-R2EL/ PKP245D23A2-R2FL
PKP245D23A2-R2E/ PKP245D23A2-R2F

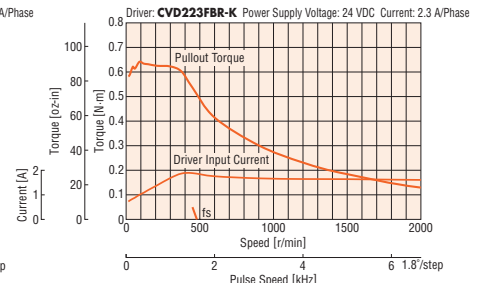

Note

● Data for the speed – torque characteristics is based on Oriental Motor's internal measurement conditions. If the conditions are changed, the characteristics may also change as a result.

● Depending on the driving conditions, a considerable amount of heat may be generated by the motor. To protect the encoder, keep the motor case temperature at 85°C (185°F) max.

● Set the current of the driver so that it does not exceed the rated current of the motor.

Speed – Torque Characteristics (Reference Values) fs: Max. Starting Frequency

PKP246D15A2-R2EL/PKP246D15A2-R2FL
PKP246D15A2-R2E/PKP246D15A2-R2F

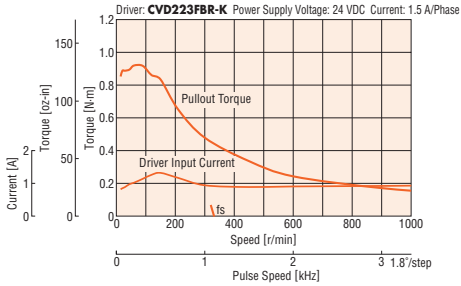

PKP246D23A2-R2EL/PKP246D23A2-R2FL
PKP246D23A2-R2E/PKP246D23A2-R2F

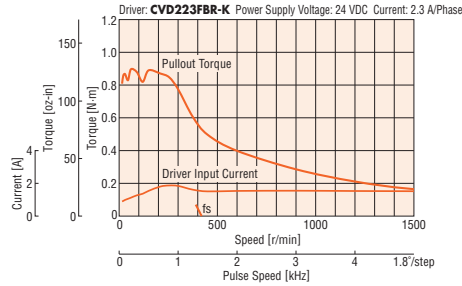

Note

- Data for the speed – torque characteristics is based on Oriental Motor's internal measurement conditions. If the conditions are changed, the characteristics may also change as a result.
- Depending on the driving conditions, a considerable amount of heat may be generated by the motor. To protect the encoder, keep the motor case temperature at 85°C (185°F) max.
- Set the current of the driver so that it does not exceed the rated current of the motor.

Dimensions Unit: mm (in.)

● Motor

2D & 3D CAD

Product Name	L	Mass kg (lb.)	2D CAD
PKP243D08A2-R2 <input type="checkbox"/>	46.5 (1.83)	0.24 (0.53)	B1321
PKP243D15A2-R2 <input type="checkbox"/>			
PKP243D23A2-R2 <input type="checkbox"/>			
PKP244D08A2-R2 <input type="checkbox"/>	52.5 (2.07)	0.31 (0.68)	B1322
PKP244D15A2-R2 <input type="checkbox"/>			
PKP244D23A2-R2 <input type="checkbox"/>			
PKP245D08A2-R2 <input type="checkbox"/>	60.5 (2.38)	0.38 (0.84)	B1323
PKP245D15A2-R2 <input type="checkbox"/>			
PKP245D23A2-R2 <input type="checkbox"/>			
PKP246D15A2-R2 <input type="checkbox"/>	72.5 (2.85)	0.51 (1.12)	B1324
PKP246D23A2-R2 <input type="checkbox"/>			

- Either **E** (200P/R) or **F** (400P/R) indicating the encoder resolution is entered where the box is located within the product name.
- A code **L** (line driver output) indicating the encoder output circuit type is entered where the box is located within the product name. The voltage output type will have no " " in the product name.

● Applicable Connector

	Motor (Hirose Electric Co., Ltd.)	Encoder (Molex)
Connector Housing	MDF97-5S-3.5C	51021-0800
Contact	MDF97-22SC	50079-8100
Crimp Tool	HT801/MDF97-22S	57177-5000

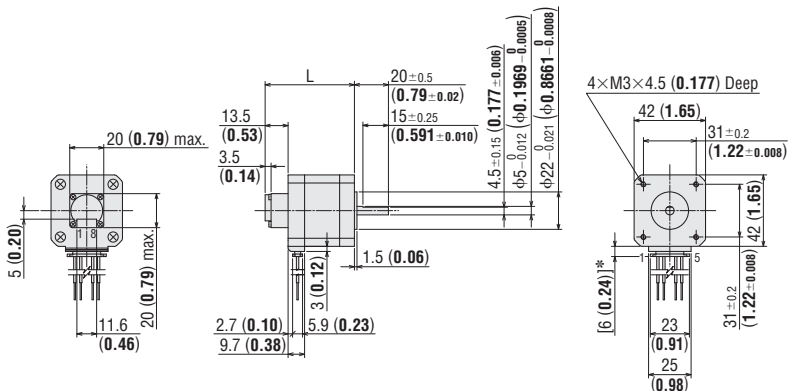

*With connection cable

Inner Wiring Diagram of Motor

Wiring Diagram No.: Model A①

- Refer to page 67 for inner wiring diagram of motor.

● Connection Cables (Sold separately)

◇ Motor Connection Cable

Product Name	Length L [m (ft.)]
LC2B06E	0.6 (2)
LC2B10E	1 (3.3)

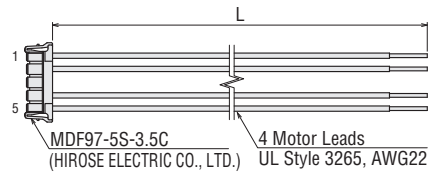

◇ Encoder Connection Cable

Encoder Output Circuit Type	Product Name	Length L [m (ft.)]
Line Driver Output Type	LC0E08A-006	0.6 (2)
Voltage Output Type	LC0E05A-006	

● LCE08A-006

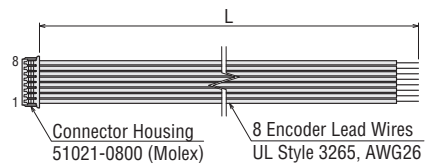

● LCE05A-006

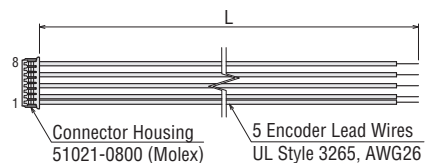

2-Phase
Motors
PKP

Features
Product
Line

Product
Number
Product Line

Standard
Type

High-
Resolution
Type

Flat Type

SH
Geared
Type

CS
Geared
Type

General
Specifications/
Inner Wiring
Diagram of Motor

5-Phase
Motors
PKP

Features
Product
Line

Product
Number
Product Line

Standard
Type

High-
Resolution
Type

TS
Geared
Type

General
Specifications/
Inner Wiring
Diagram of Motor

Driver for
2-Phase/
5-Phase Motors

Accessories

Standard Type with Electromagnetic Brake Frame Size 42 mm (1.65 in.) (Bipolar 4 Lead Wires)

20 mm
(0.79 in.)

28 mm
(1.10 in.)

35 mm
(1.38 in.)

42 mm
(1.65 in.)

50 mm
(1.97 in.)
51 mm
(2.01 in.)

56.4 mm
(2.22 in.)

60 mm
(2.36 in.)
61 mm
(2.40 in.)

85 mm
(3.35 in.)

Specifications

Product Name	Maximum Holding Torque N·m (oz·in)	Rotor Inertia J: kg·m ² (oz·in ²)	Rated Current A/Phase	Voltage VDC	Winding Resistance Ω/Phase	Inductance mH/Phase	Basic Step Angle	Electricmagnetic Brake Static Friction Torque N·m (oz·in)
PKP243D23M2	0.35 (49)	48×10^{-7} (0.26)*	2.3	1.8	0.78	1.4	1.8°	0.3 (42)
PKP244D23M2	0.48 (68)	69×10^{-7} (0.38)*		2.1	0.93	1.9		
PKP245D23M2	0.66 (93)	85×10^{-7} (0.46)*		2.3	1	2.2		
PKP246D23M2	0.99 (140)	120×10^{-7} (0.66)*		3.2	1.4	3.3		

See page 64 for electromagnetic brake specifications.

*The Inertia of the electromagnetic brake is included in the value.

Speed – Torque Characteristics (Reference Values) fs: Max. Starting Frequency

PKP243D23M2

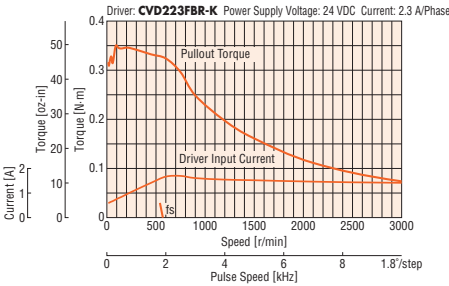

PKP244D23M2

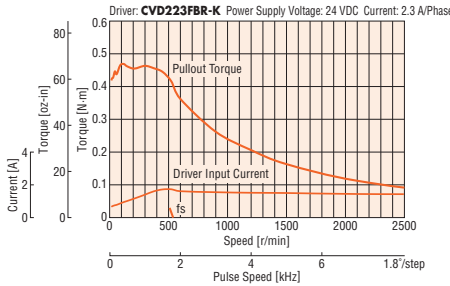

PKP245D23M2

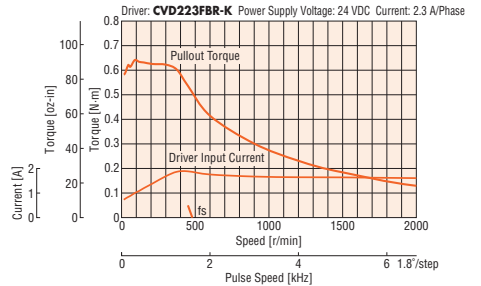

PKP246D23M2

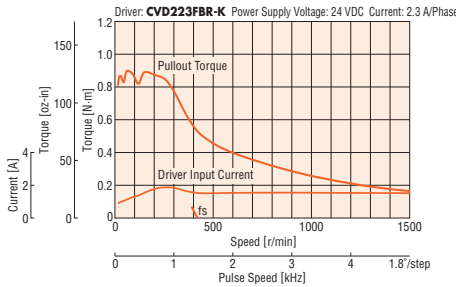

Note

- Data for the speed – torque characteristics is based on Oriental Motor's internal measurement conditions. If the conditions are changed, the characteristics may also change as a result.
- Depending on the driving conditions, a considerable amount of heat may be generated by the motor. Be sure to keep the temperature of the motor case under 100°C (212°F).
- Set the current of the driver so that it does not exceed the rated current of the motor.

Dimensions Unit: mm (in.)

Motor

2D & 3D CAD

Product Name	L1	L2	Mass kg (lb.)	2D CAD
PKP243D23M2	69 (2.72)	49 (1.93)	0.33 (0.73)	B1435
PKP244D23M2	75 (2.95)	55 (2.17)	0.40 (0.88)	B1436
PKP245D23M2	83 (3.27)	63 (2.84)	0.47 (1.03)	B1437
PKP246D23M2	95 (3.74)	75 (2.95)	0.60 (1.32)	B1438

Applicable Connector

	Motor (Hirose Electric Co., Ltd.)	Electromagnetic Brake (Hirose Electric Co., Ltd.)
Connector Housing	MDF97-5S-3.5C	DF62C-2S-2.2C
Contact	MDF97-22SC	DF62-22SCA
Crimp Tool	HT801/MDF97-22S	HT801/DF62-22(10)

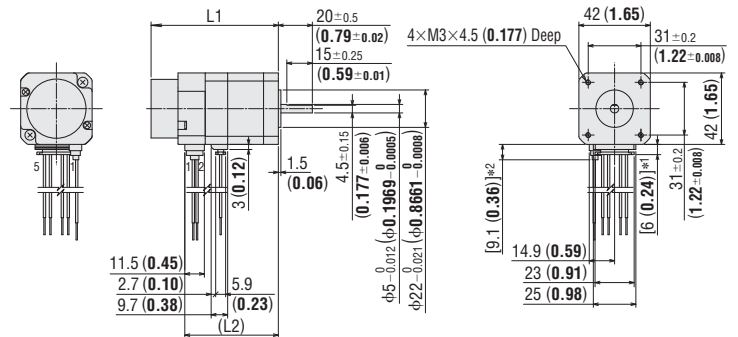

Connection Cables (Sold separately)

Motor Connection Cable

Product Name	Length L [m (ft.)]
LC2B06E	0.6 (2)
LC2B10E	1 (3.3)

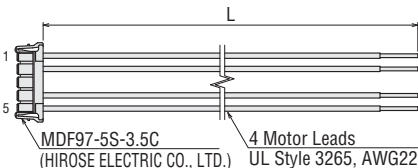

Electromagnetic Brake Connection Cable

Product Name	Length L [m (ft.)]
LCM02A-006	0.6 (2)
LCM02A-010	1 (3.3)

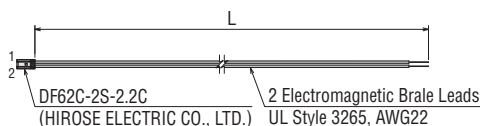

Inner Wiring Diagram of Motor

Wiring Diagram No.: Model A①

Refer to page 67 for inner wiring diagram of motor.

Standard Type

Frame Size 50 mm (1.97 in.) (Bipolar 4 Lead Wires)

2-Phase Motors PKP

Specifications

Product Name	Maximum Holding Torque N·m (oz·in)	Rotor Inertia J: kg·m ² (oz·in ²)	Rated Current A/Phase	Voltage VDC	Winding Resistance Ω/Phase	Inductance mH/Phase	Basic Step Angle	Recommended Driver Product Name*
PKP254D28□A2	0.63 (89)	120×10 ⁻⁷ (0.66)	2.8	1.5	0.55	1.1	1.8°	CVD228BR-K
PKP256D28□A2	1.08 (153)	220×10 ⁻⁷ (1.20)		2	0.7	1.6		
PKP258D28□A2	1.99 (280)	450×10 ⁻⁷ (2.5)		3.1	1.1	2.8		

● The box □ in the product name indicates the shaft **A** (single shaft) or **B** (double shaft).

* See page 94 for details on the recommended drivers.

Speed – Torque Characteristics (Reference Values) fs: Max. Starting Frequency

PKP254D28AA2/ PKP254D28BA2

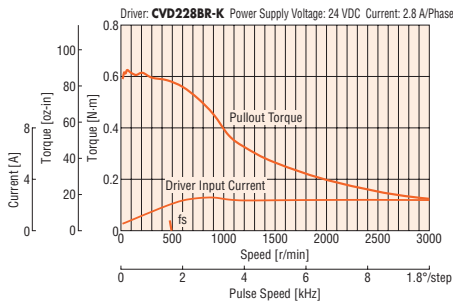

PKP256D28AA2/ PKP256D28BA2

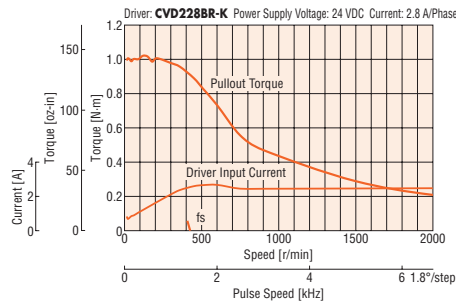

PKP258D28AA2/ PKP258D28BA2

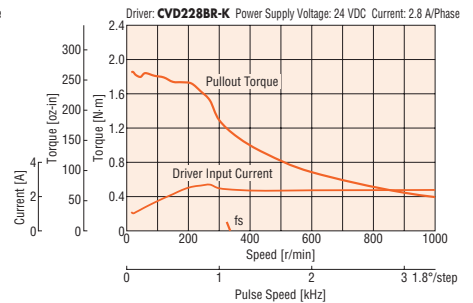

Note

- Data for the speed – torque characteristics is based on Oriental Motor's internal measurement conditions. If the conditions are changed, the characteristics may also change as a result.
- Depending on the driving conditions, a considerable amount of heat may be generated by the motor. Be sure to keep the temperature of the motor case under 100°C (212°F).
- Set the current of the driver so that it does not exceed the rated current of the motor.

Dimensions Unit: mm (in.)

Motor

2D & 3D CAD

Product Name	L1	L2	Mass kg (lb.)	2D CAD
PKP254D28AA2	39	—	0.37 (0.81)	B1452
PKP254D28BA2	(1.54)	55 (2.17)		
PKP256D28AA2	51.5	—	0.54 (1.19)	B1453
PKP256D28BA2	(2.03)	67.5 (2.66)		
PKP258D28AA2	81	—	0.93 (2.0)	B1454
PKP258D28BA2	(3.19)	97 (3.82)		

Applicable Connector

Connector Housing: MDF97-5S-3.5C (HIROSE ELECTRIC CO., LTD.)
Contact: MDF97-22SC (HIROSE ELECTRIC CO., LTD.)
Crimp Tool: HT801/MDF97-22S (HIROSE ELECTRIC CO., LTD.)

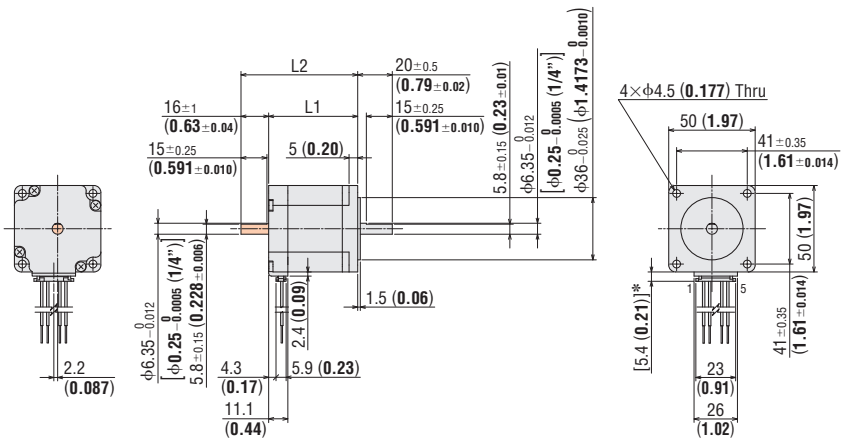

*With connection cable

● These dimensions are for double shaft products.

For single shaft products, ignore the shaded areas.

Connection Cables (Sold separately)

Motor Connection Cable

Product Name	Length L [m (ft.)]
LC2B06E	0.6 (2)
LC2B10E	1 (3.3)

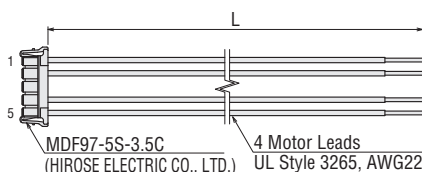

Inner Wiring Diagram of Motor

Wiring Diagram No.: Model A①

● Refer to page 67 for inner wiring diagram of motor.

Features Product Line

Product Number Product Line

Standard Type

High-Resolution Type

Flat Type

SH Geared Type

CS Geared Type

General Specifications/ Inner Wiring Diagram of Motor

5-Phase Motors PKP

Features Product Line

Product Number Product Line

Standard Type

High-Resolution Type

TS Geared Type

General Specifications/ Inner Wiring Diagram of Motor

Driver for 2-Phase/ 5-Phase Motors

Accessories

Standard Type with Encoder Frame Size 50 mm (1.97 in.) (Bipolar 4 Lead Wires)

- 20 mm (0.79 in.)
- 28 mm (1.10 in.)
- 35 mm (1.38 in.)
- 42 mm (1.65 in.)
- 50 mm (1.97 in.)
- 51 mm (2.01 in.)
- 56.4 mm (2.22 in.)
- 60 mm (2.36 in.)
- 61 mm (2.40 in.)
- 85 mm (3.35 in.)

Specifications

Product Name	Maximum Holding Torque N·m (oz·in)	Rotor Inertia J: kg·m ² (oz·in ²)	Rated Current A/Phase	Voltage VDC	Winding Resistance Ω/Phase	Inductance mH/Phase	Basic Step Angle	Recommended Driver Product Name*
PKP254D28AA2-R2□	0.63 (89)	120×10 ⁻⁷ (0.66)	2.8	1.5	0.55	1.1	1.8°	CVD228BR-K
PKP256D28AA2-R2□	1.08 (153)	220×10 ⁻⁷ (1.20)		2	0.7	1.6		
PKP258D28AA2-R2□	1.99 (280)	450×10 ⁻⁷ (2.5)		3.1	1.1	2.8		

- The box □ in the product name indicates the encoder resolution **E** (200 P/R) or **F** (400 P/R).
- The box ■ in the product name indicates the encoder output circuit type **L** (line driver output). The voltage output type will have no "■" in the product name.
- See page 64 for encoder specifications.
- * See page 94 for details on the recommended drivers.

Speed – Torque Characteristics (Reference Values) fs: Max. Starting Frequency

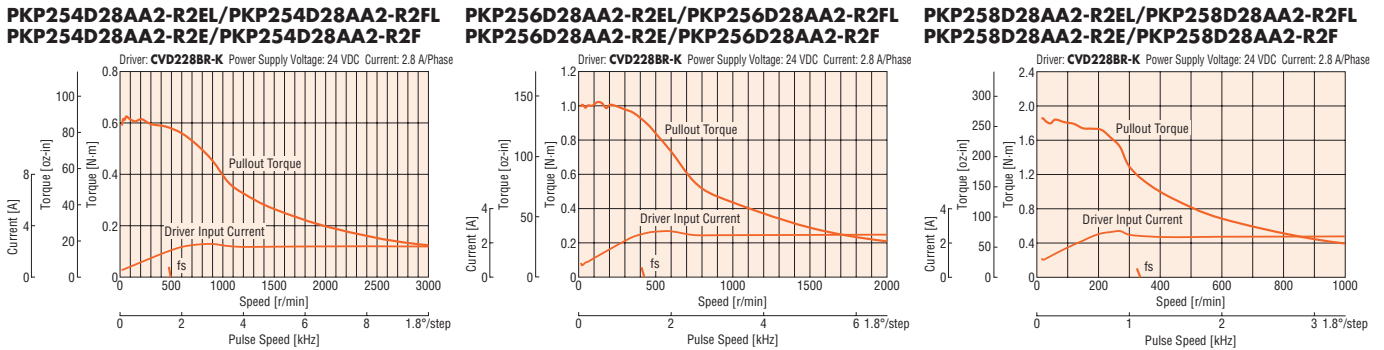

- Note**
- Data for the speed – torque characteristics is based on Oriental Motor's internal measurement conditions. If the conditions are changed, the characteristics may also change as a result.
 - Depending on the driving conditions, a considerable amount of heat may be generated by the motor. To protect the encoder, keep the motor case temperature at 85°C (185°F) max.
 - Set the current of the driver so that it does not exceed the rated current of the motor.

Dimensions Unit: mm (in.)

Motor 2D & 3D CAD

Product Name	L	Mass kg (lb.)	2D CAD
PKP254D28AA2-R2□	55.5 (2.19)	0.37 (0.81)	B1458
PKP256D28AA2-R2□	68 (2.68)	0.54 (1.19)	B1459
PKP258D28AA2-R2□	97.5 (3.84)	0.93 (2.0)	B1460

- Either **E** (200P/R) or **F** (400P/R) indicating the encoder resolution is entered where the box □ is located within the product name.
- A code **L** (line driver output) indicating the encoder output circuit type is entered where the box ■ is located within the product name. The voltage output type will have no "■" in the product name.

Applicable Connector

	Motor (Hirose Electric Co., Ltd.)	Encoder (Molex)
Connector Housing	MDF97-5S-3.5C	51021-0800
Contact	MDF97-22SC	50079-8100
Crimp Tool	HT801/MDF97-22S	57177-5000

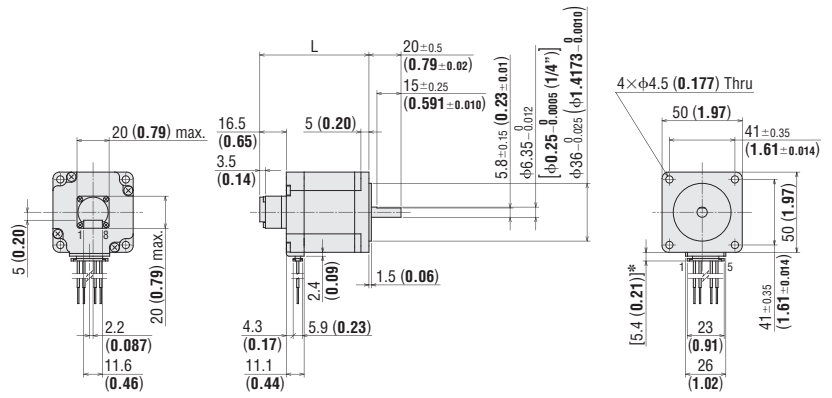

Connection Cables (Sold separately)

Motor Connection Cable

Product Name	Length L [m (ft.)]
LC2B06E	0.6 (2)
LC2B10E	1 (3.3)

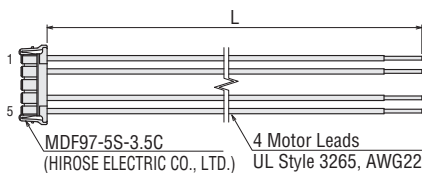

Encoder Connection Cable

Encoder Output Circuit Type	Product Name	Length L [m (ft.)]
Line Driver Output Type	LCE08A-006	0.6 (2)
Voltage Output Type	LCE05A-006	

•LCE08A-006

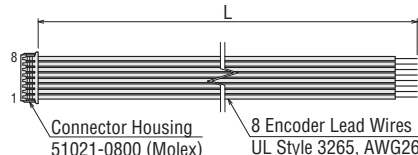

•LCE05A-006

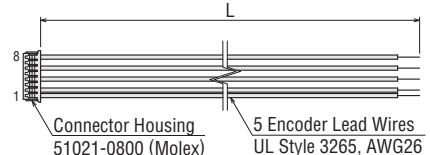

Inner Wiring Diagram of Motor

Wiring Diagram No.: Model A①

- Refer to page 67 for inner wiring diagram of motor.

Standard Type

Frame Size 56.4 mm (2.22 in.) (Bipolar 4 Lead Wires)

2-Phase
Motors
PKP

Features
Product
Line

Product
Number
Product Line

Standard
Type

High-
Resolution
Type

Flat Type

SH
Geared
Type

CS
Geared
Type

General
Specifications/
Inner Wiring
Diagram of Motor

5-Phase
Motors
PKP

Features
Product
Line

Product
Number
Product Line

Standard
Type

High-
Resolution
Type

TS
Geared
Type

General
Specifications/
Inner Wiring
Diagram of Motor

Driver for
2-Phase/
5-Phase Motors

Accessories

Specifications

Product Name	Maximum Holding Torque N·m (oz·in)	Rotor Inertia J: kg·m ² (oz·in ²)	Rated Current A/Phase	Voltage VDC	Winding Resistance Ω/Phase	Inductance mH/Phase	Basic Step Angle	Recommended Driver Product Name*
PKP264D14□2	0.74 (105)	140×10 ⁻⁷ (0.77)	1.4	2.9	2.1	6	1.8°	CVD228BR-K
PKP264D28□2			2.8	1.6	0.57	1.5		
PKP264D42□2			4.2	1	0.24	0.65		
PKP266D14□2	1.4 (198)	270×10 ⁻⁷ (1.48)	1.4	4.6	3.3	12		CVD228BR-K
PKP266D28□2			2.8	2.4	0.86	2.9		CVD242BR-K
PKP266D42□2			4.2	1.6	0.38	1.3		CVD242BR-K
PKP268D14□2	2.5 (350)	500×10 ⁻⁷ (2.7)	1.4	6.6	4.7	18		CVD228BR-K
PKP268D28□2			2.8	3.4	1.2	4.6		CVD228BR-K
PKP268D42□2			4.2	2.2	0.53	2		CVD242BR-K

● The box □ in the product name indicates the shaft **A** (single shaft) or **B** (double shaft).

*See page 94 for details on the recommended drivers.

Speed – Torque Characteristics

PKP264D14A2/PKP264D14B2

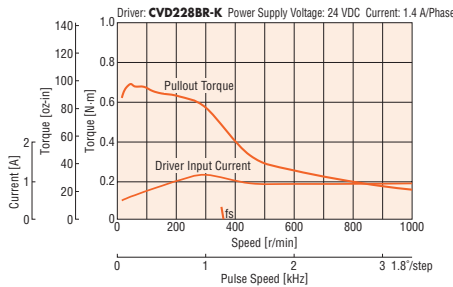

PKP264D28A2/PKP264D28B2

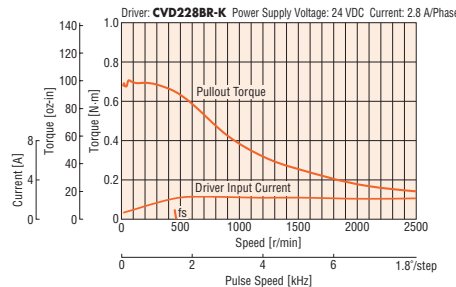

PKP264D42A2/PKP264D42B2

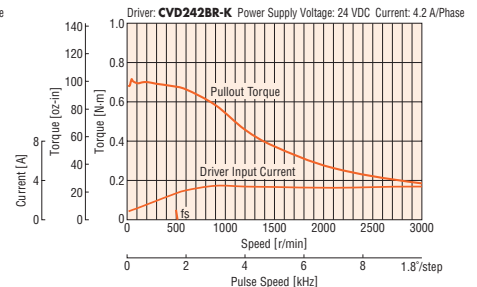

PKP266D14A2/PKP266D14B2

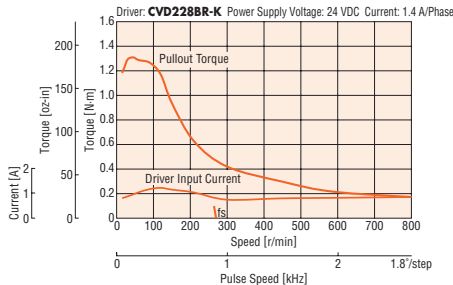

PKP266D28A2/PKP266D28B2

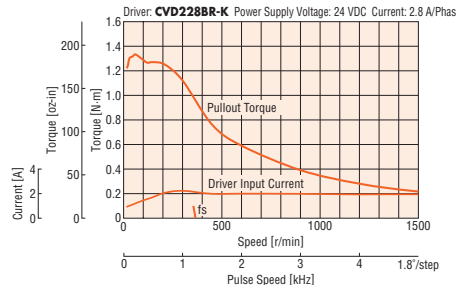

PKP266D42A2/PKP266D42B2

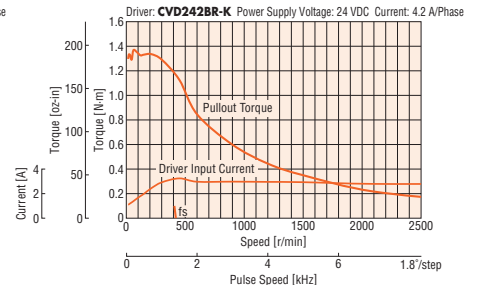

PKP268D14A2/PKP268D14B2

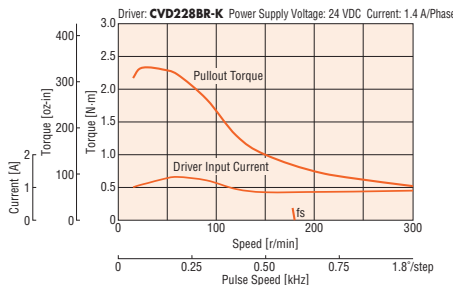

PKP268D28A2/PKP268D28B2

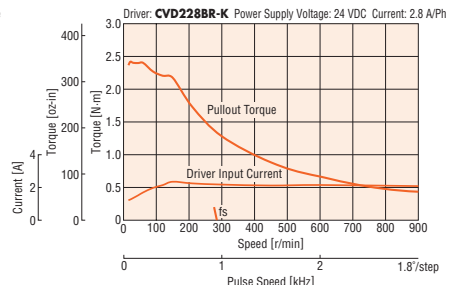

PKP268D42A2/PKP268D42B2

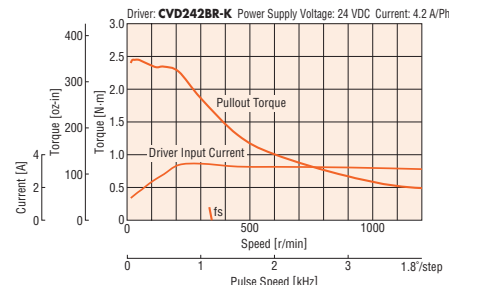

Note

- Data for the speed – torque characteristics is based on Oriental Motor's internal measurement conditions. If the conditions are changed, the characteristics may also change as a result.
- Depending on the driving conditions, a considerable amount of heat may be generated by the motor. Be sure to keep the temperature of the motor case under 100°C (212°F).
- Set the current of the driver so that it does not exceed the rated current of the motor.

Motor
Frame Size

20 mm
(0.79 in.)

28 mm
(1.10 in.)

35 mm
(1.38 in.)

42 mm
(1.65 in.)

50 mm
(1.97 in.)
51 mm
(2.01 in.)

56.4 mm
(2.22 in.)

60 mm
(2.36 in.)
61 mm
(2.40 in.)

85 mm
(3.35 in.)

Dimensions Unit: mm (in.)

● Motor

2D & 3D CAD

Product Name	L1	L2	Mass kg (lb.)	2D CAD
PKP264D14A2	39 (1.54)	—	0.45 (0.99)	B1357
PKP264D14B2		62 (2.44)		
PKP264D28A2		—		
PKP264D28B2		62 (2.44)		
PKP264D42A2	54 (2.13)	—	0.7 (1.54)	B1358
PKP266D14B2		77 (3.03)		
PKP266D28A2		—		
PKP266D28B2		77 (3.03)		
PKP266D42A2	76 (2.99)	—	1.1 (2.4)	B1251
PKP268D14A2		99 (3.90)		
PKP268D28A2		—		
PKP268D28B2		99 (3.90)		
PKP268D42A2	—	—	—	—
PKP268D42B2				

- Applicable Connector
Connector Housing: MDF97-5S-3.5C (HIROSE ELECTRIC CO., LTD.)
Contact: MDF97-22SC (HIROSE ELECTRIC CO., LTD.)
Crimp Tool: HT801/MDF97-22S (HIROSE ELECTRIC CO., LTD.)

● Connection Cables (Sold separately)

◇ Motor Connection Cable

Product Name	Length L [m (ft.)]
LC2B06E	0.6 (2)
LC2B10E	1 (3.3)

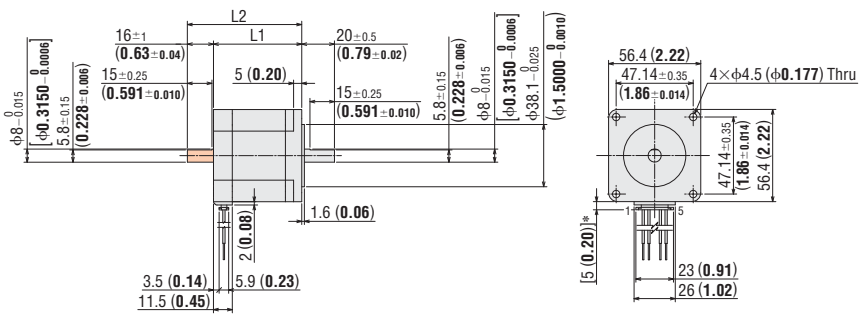
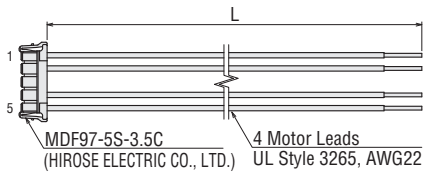

- *With connection cable
- These dimensions are for double shaft products.
For single shaft products, ignore the [shaded] areas.

Inner Wiring Diagram of Motor

Wiring Diagram No.: Model A①

- Refer to page 67 for inner wiring diagram of motor.

Standard Type with Encoder Frame Size 56.4 mm (2.22 in.) (Bipolar 4 Lead Wires)

2-Phase Motors PKP

Specifications

Product Name	Maximum Holding Torque N·m (oz·in)	Rotor Inertia J: kg·m ² (oz·in ²)	Rated Current A/Phase	Voltage VDC	Winding Resistance Ω/Phase	Inductance mH/Phase	Basic Step Angle	Recommended Driver Product Name*
PKP264D14A2-R2□□	0.74 (105)	140×10 ⁻⁷ (0.77)	1.4	2.9	2.1	6	1.8°	CVD228BR-K
PKP264D28A2-R2□□			2.8	1.6	0.57	1.5		
PKP264D42A2-R2□□			4.2	1	0.24	0.65		
PKP266D14A2-R2□□	1.4 (198)	270×10 ⁻⁷ (1.48)	1.4	4.6	3.3	12		CVD228BR-K
PKP266D28A2-R2□□			2.8	2.4	0.86	2.9		
PKP266D42A2-R2□□			4.2	1.6	0.38	1.3		
PKP268D14A2-R2□□	2.5 (350)	500×10 ⁻⁷ (2.7)	1.4	6.6	4.7	18		CVD228BR-K
PKP268D28A2-R2□□			2.8	3.4	1.2	4.6		
PKP268D42A2-R2□□			4.2	2.2	0.53	2		

● The box □ in the product name indicates the encoder resolution **E** (200 P/R) or **F** (400 P/R).

The box ■ in the product name indicates the encoder output circuit type **L** (line driver output). The voltage output type will have no "■" in the product name.

● See page 64 for encoder specifications.

*See page 94 for details on the recommended drivers.

Features Product Line

Product Number Product Line

Standard Type

High-Resolution Type

Flat Type

SH Geared Type

CS Geared Type

General Specifications/Inner Wiring Diagram of Motor

Speed – Torque Characteristics (Reference Values) *f_s*: Max. Starting Frequency

PKP264D14A2-R2EL/ PKP264D14A2-R2FL
PKP264D14A2-R2E/ PKP264D14A2-R2F

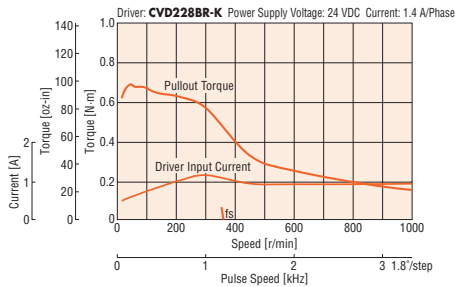

PKP264D28A2-R2EL/ PKP264D28A2-R2FL
PKP264D28A2-R2E/ PKP264D28A2-R2F

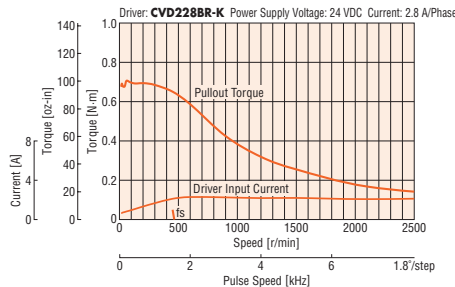

PKP264D42A2-R2EL/ PKP264D42A2-R2FL
PKP264D42A2-R2E/ PKP264D42A2-R2F

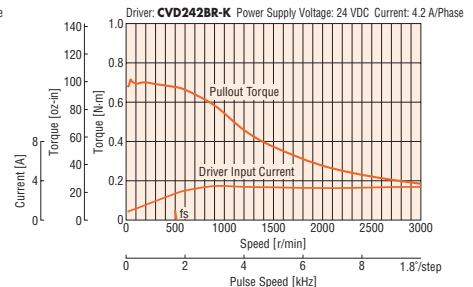

PKP266D14A2-R2EL/ PKP266D14A2-R2FL
PKP266D14A2-R2E/ PKP266D14A2-R2F

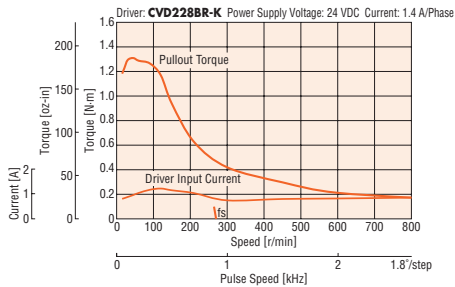

PKP266D28A2-R2EL/ PKP266D28A2-R2FL
PKP266D28A2-R2E/ PKP266D28A2-R2F

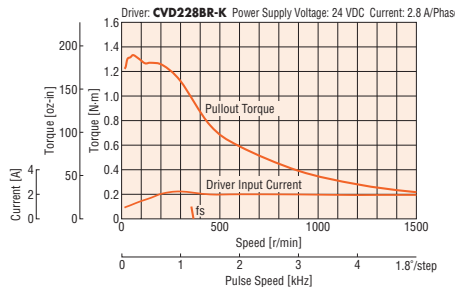

PKP266D42A2-R2EL/ PKP266D42A2-R2FL
PKP266D42A2-R2E/ PKP266D42A2-R2F

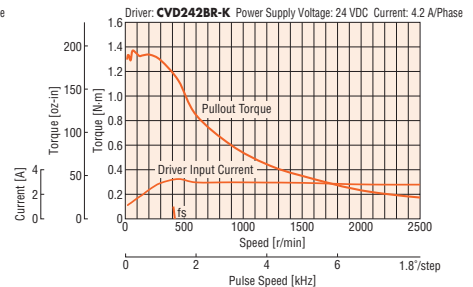

PKP268D14A2-R2EL/ PKP268D14A2-R2FL
PKP268D14A2-R2E/ PKP268D14A2-R2F

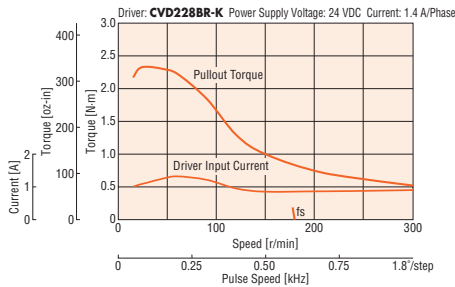

PKP268D28A2-R2EL/ PKP268D28A2-R2FL
PKP268D28A2-R2E/ PKP268D28A2-R2F

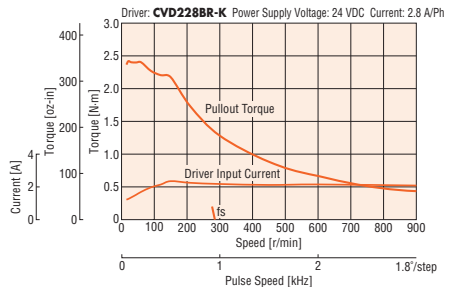

PKP268D42A2-R2EL/ PKP268D42A2-R2FL
PKP268D42A2-R2E/ PKP268D42A2-R2F

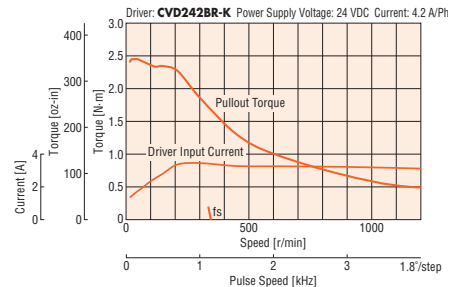

Note

- Data for the speed – torque characteristics is based on Oriental Motor's internal measurement conditions. If the conditions are changed, the characteristics may also change as a result.
- Depending on the driving conditions, a considerable amount of heat may be generated by the motor. To protect the encoder, be sure to keep the motor case temperature at 85°C (185°F) max.
- Set the current of the driver so that it does not exceed the rated current of the motor.

5-Phase Motors PKP

Features Product Line

Product Number Product Line

Standard Type

High-Resolution Type

TS Geared Type

General Specifications/Inner Wiring Diagram of Motor

Driver for 2-Phase/5-Phase Motors

Accessories

- Motor Frame Size
- 20 mm (0.79 in.)
 - 28 mm (1.10 in.)
 - 35 mm (1.38 in.)
 - 42 mm (1.65 in.)
 - 50 mm (1.97 in.)
 - 51 mm (2.01 in.)
 - 56.4 mm (2.22 in.)
 - 60 mm (2.36 in.)
 - 61 mm (2.40 in.)
 - 85 mm (3.35 in.)

Dimensions Unit = mm (in.)

Motor

2D & 3D CAD

Product Name	L	Mass kg (lb.)	2D CAD
PKP264D14A2-R2□□	55.5 (2.19)	0.45 (0.99)	B1325
PKP264D28A2-R2□□			
PKP264D42A2-R2□□			
PKP266D14A2-R2□□	70.5 (2.78)	0.7 (1.54)	B1326
PKP266D28A2-R2□□			
PKP266D42A2-R2□□			
PKP268D14A2-R2□□	92.5 (3.64)	1.1 (2.4)	B1327
PKP268D28A2-R2□□			
PKP268D42A2-R2□□			

● The box □ in the product name indicates the encoder resolution **E** (200 P/R) or **F** (400 P/R).

The box ■ in the product name indicates the encoder output circuit type **L** (line driver output). The voltage output type will have no "■" in the product name.

Applicable Connector

	Motor (HIROSE ELECTRIC CO.,LTD.)	Encoder (Molex)
Connector Housing	MDF97-5S-3.5C	51021-0800
Contact	MDF97-22SC	50079-8100
Crimp Tool	HT801/MDF97-22S	57177-5000

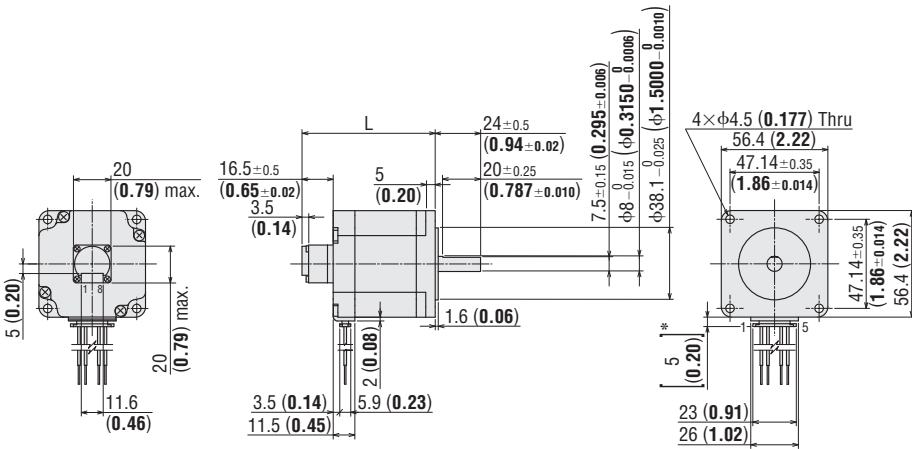

*With connection cable

Connection Cable (Sold separately)

◇ Motor Connection Cable

Product Name	Length L [m (ft.)]
LC2B06E	0.6 (2)
LC2B10E	1 (3.3)

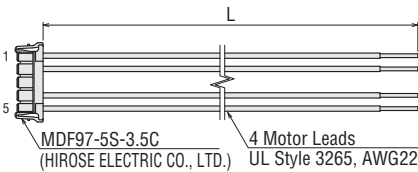

◇ Encoder Connection Cable

Encoder Output Circuit Type	Product Name	Length L [m (ft.)]
Line Driver Output Type	LCE08A-006	0.6 (2)
Voltage Output Type	LCE05A-006	

● LCE08A-006

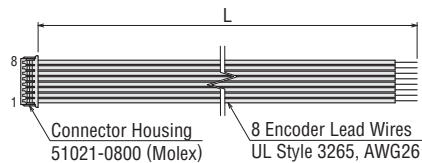

● LCE05A-006

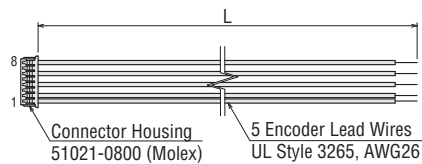

Inner Wiring Diagram of Motor

Wiring Diagram No.: Model A①

● Refer to page 67 for inner wiring diagram of motor.

Standard Type with Electromagnetic Brake Frame Size 56.4 mm (2.22 in.) (Bipolar 4 Lead Wires)

2-Phase Motors
PKP

Features Product Line

Product Number Product Line

Standard Type

High-Resolution Type

Flat Type

SH Geared Type

CS Geared Type

General Specifications/ Inner Wiring Diagram of Motor

5-Phase Motors
PKP

Features Product Line

Product Number Product Line

Standard Type

High-Resolution Type

TS Geared Type

General Specifications/ Inner Wiring Diagram of Motor

Driver for 2-Phase/ 5-Phase Motors

Accessories

Specifications

Product Name	Maximum Holding Torque N·m (oz·in)	Rotor Inertia J: kg·m ² (oz·in ²)	Rated Current A/Phase	Voltage VDC	Winding Resistance Ω/Phase	Inductance mH/Phase	Basic Step Angle	Electricmagnetic Brake Static Friction Torque N·m (oz·in)
PKP264D28M2	0.74 (105)	270×10 ⁻⁷ (1.48)*	2.8	1.6	0.57	1.5	1.8°	0.8 (113)
PKP266D28M2	1.4 (198)	400×10 ⁻⁷ (2.2)*		2.4	0.86	2.9		
PKP268D28M2	2.5 (350)	630×10 ⁻⁷ (3.4)*		3.4	1.2	4.6		

● See page 64 for electromagnetic brake specifications.

*The Inertia of the electromagnetic brake is included in the value.

Speed – Torque Characteristics (Reference Values) *f_s*: Max. Starting Frequency

PKP264D28M2

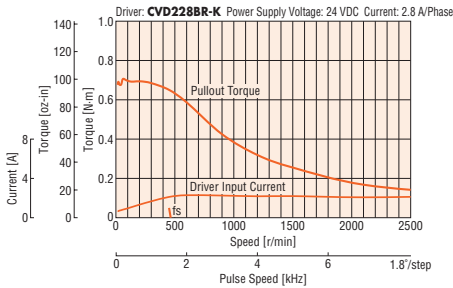

PKP266D28M2

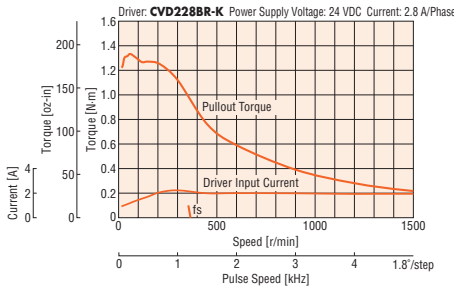

PKP268D28M2

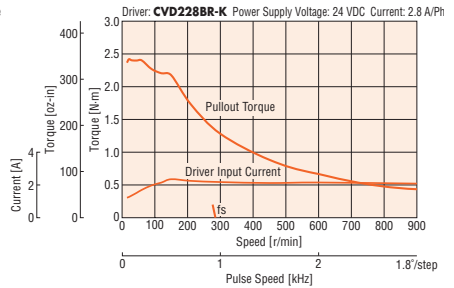

Note

- Data for the speed – torque characteristics is based on Oriental Motor's internal measurement conditions. If the conditions are changed, the characteristics may also change as a result.
- Depending on the driving conditions, a considerable amount of heat may be generated by the motor. Be sure to keep the motor case temperature at 100°C (212°F) max.
- Set the current of the driver so that it does not exceed the rated current of the motor.

Dimensions Unit = mm (in.)

● Motor

2D & 3D CAD

Product Name	L1	L2	Mass kg (lb.)	2D CAD
PKP264D28M2	73.5 (2.89)	55.3 (2.18)	0.65 (1.43)	B1439
PKP266D28M2	88.5 (3.48)	70.3 (2.77)	0.9 (1.98)	B1440
PKP268D28M2	110.5 (4.35)	92.3 (3.63)	1.3 (2.9)	B1441

● Applicable Connector

	Motor (Hirose Electric Co., Ltd.)	Electromagnetic Brake (Hirose Electric Co., Ltd.)
Connector Housing	MDF97-5S-3.5C	DF62C-2S-2.2C
Contact	MDF97-22SC	DF62-22SCA
Crimp Tool	HT801/MDF97-22S	HT801/DF62-22(10)

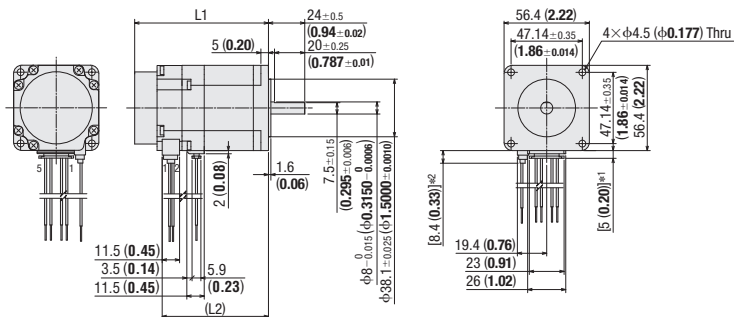

● Connection Cable (Sold separately)

◇ Motor Connection Cable

Product Name	Length L [m (ft.)]
LC2B06E	0.6 (2)
LC2B10E	1 (3.3)

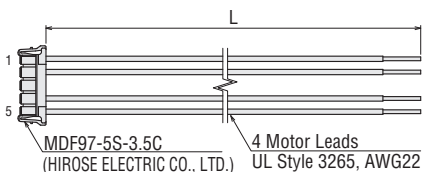

◇ Electromagnetic Brake Connection Cable

Product Name	Length L [m (ft.)]
LCM02A-006	0.6 (2)
LCM02A-010	1 (3.3)

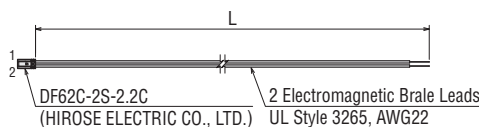

Inner Wiring Diagram of Motor

Wiring Diagram No.: Model A①

● Refer to page 67 for inner wiring diagram of motor.

Standard Type

Frame Size 60 mm (2.36 in.) (Bipolar 4 Lead Wires)

Specifications

Product Name	Maximum Holding Torque N·m (oz·in)	Rotor Inertia J: kg·m ² (oz·in ²)	Rated Current A/Phase	Voltage VDC	Winding Resistance Ω/Phase	Inductance mH/Phase	Basic Step Angle
PV264-D2.8□A	1.06 (150)	280×10 ⁻⁷ (1.53)	2.8	2.1	0.73	1.8	1.8°
PV266-D2.8□A	1.75 (240)	450×10 ⁻⁷ (2.5)		2.8	1	3.05	
PV267-D2.8□A	2.2 (310)	570×10 ⁻⁷ (3.1)		3.4	1.2	3.54	
PV269-D2.8□A	3.1 (440)	900×10 ⁻⁷ (4.9)		4.2	1.49	5.7	

● The box □ in the product name indicates the shaft **A** (single shaft) or **B** (double shaft).

Speed – Torque Characteristics (Reference Values) fs: Max. Starting Frequency

PV264-D2.8AA/PV264-D2.8BA

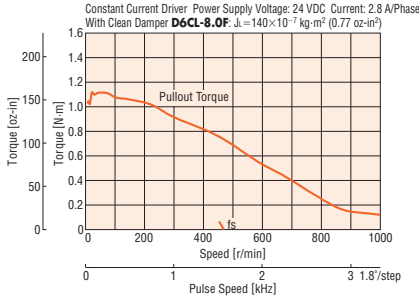

PV266-D2.8AA/PV266-D2.8BA

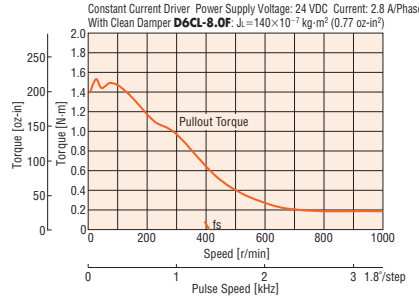

PV267-D2.8AA/PV267-D2.8BA

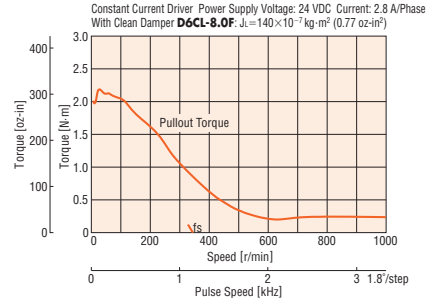

PV269-D2.8AA/PV269-D2.8BA

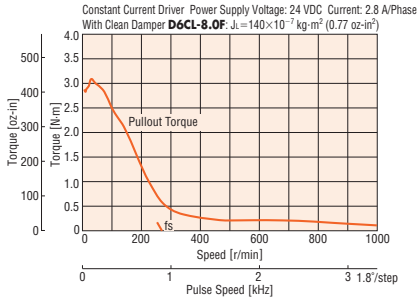

Note

- Data for the speed – torque characteristics is based on Oriental Motor's internal measurement conditions. If the conditions are changed, the characteristics may also change as a result.
- If there is a "clean damper" entry in the speed – torque characteristics, the data is for a double shaft motor when a clean damper is equipped.
- Depending on the driving conditions, a considerable amount of heat may be generated by the motor. Be sure to keep the motor case temperature at 100°C (212°F) max.
- Set the current of the driver so that it does not exceed the rated current of the motor.

Dimensions Unit = mm (in.)

Motor

2D & 3D CAD

Product Name	L1	L2	Mass kg (lb.)	2D CAD
PV264-D2.8AA	43.5	—	0.6	B279
PV264-D2.8BA	(1.71)	66.5 (2.62)	(1.32)	
PV266-D2.8AA	54	—	0.83	B232
PV266-D2.8BA	(2.13)	77 (3.04)	(1.83)	
PV267-D2.8AA	65	—	1.02	B233
PV267-D2.8BA	(2.56)	88 (3.47)	(2.2)	
PV269-D2.8AA	85	—	1.43	B280
PV269-D2.8BA	(3.35)	101 (3.98)	(3.1)	

Inner Wiring Diagram of Motor

Wiring Diagram No.: Model C⑤

● Refer to page 67 for inner wiring diagram of motor.

● PV264, PV266, PV267

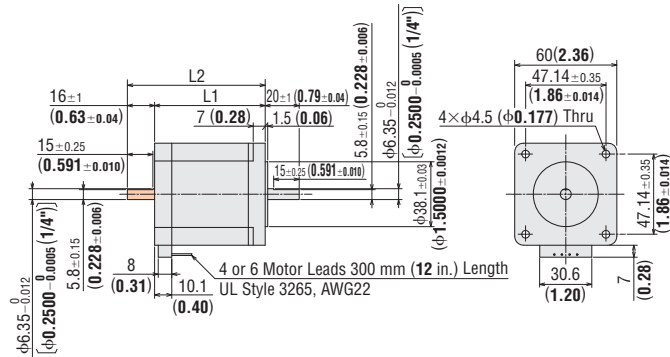

● PV269

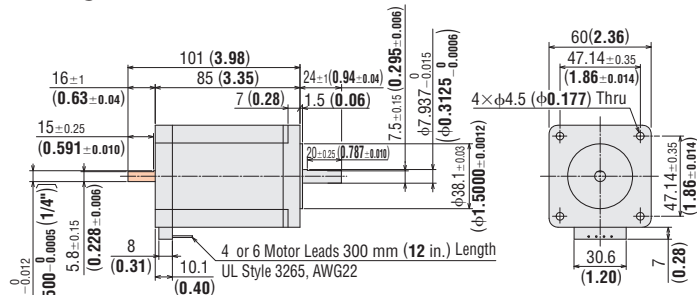

● These dimensions are for double shaft motors.
For single shaft motors, ignore the shaded areas.

Standard Type

Frame Size 85 mm (3.35 in.) (Bipolar 4 Lead Wires)

2-Phase Motors
PKP

Specifications

Product Name	Maximum Holding Torque N·m (oz·in)	Rotor Inertia J: kg·m ² (oz·in ²)	Rated Current A/Phase	Voltage VDC	Winding Resistance Ω/Phase	Inductance mH/Phase	Basic Step Angle	Recommended Driver Product Name*
PKP296D45□A	3.3	1100×10 ⁻⁷	4.5	1.9	0.42	3.1	1.8°	CVD245BR-K
PKP296D63□A	(29)	(6)	6.3	1.4	0.23	1.6		-
PKP299D45□A	6.4	2200×10 ⁻⁷	4.5	2.7	0.6	5.4		CVD245BR-K
PKP299D63□A	(56)	(12)	6.3	2	0.32	2.6		-
PKP2913D45□A	9.5	3400×10 ⁻⁷	4.5	3.5	0.78	6.9		CVD245BR-K
PKP2913D56□A	(84)	(18.6)	5.6	2.6	0.47	4.4		-

● The box □ in the product name indicates the shaft **A** (single shaft) or **B** (double shaft).

*See page 94 for details on the recommended drivers.

Speed – Torque Characteristics (Reference Values) *f_s*: Max. Starting Frequency

PKP296D45AA/PKP296D45BA

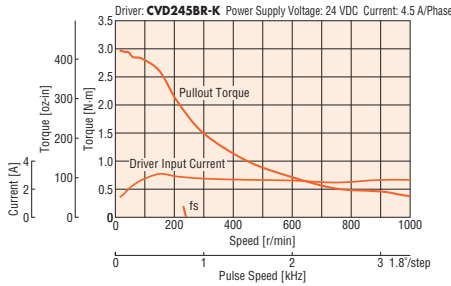

PKP299D45AA/PKP299D45BA

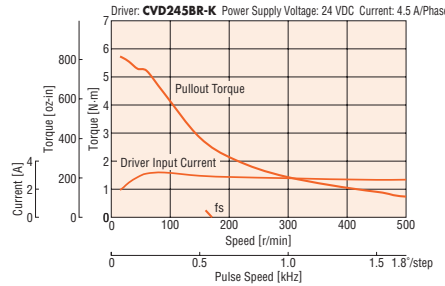

PKP2913D45AA/PKP2913D45BA

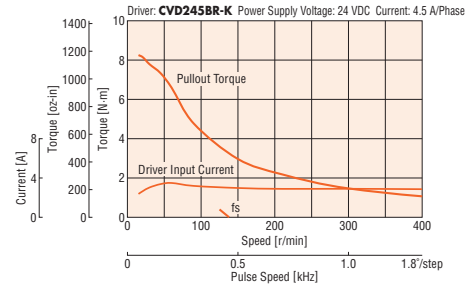

PKP296D63AA/PKP296D63BA

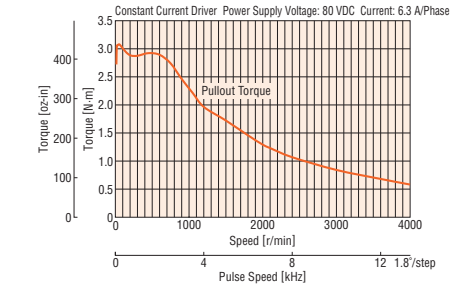

PKP299D63AA/PKP299D63BA

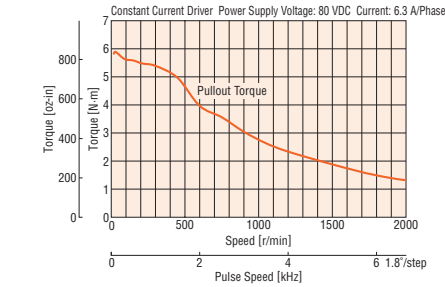

PKP2913D56AA/PKP2913D56BA

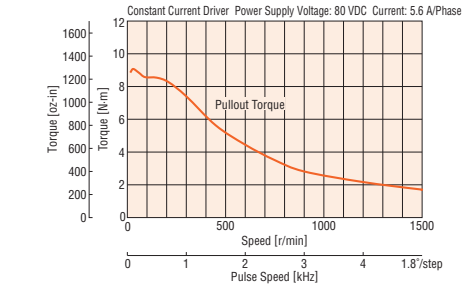

Note

- Data for the speed – torque characteristics is based on Oriental Motor's internal measurement conditions. If the conditions are changed, the characteristics may also change as a result.
- Depending on the driving conditions, a considerable amount of heat may be generated by the motor. Be sure to keep the motor case temperature at 100°C (212°F) max.
- Set the current of the driver so that it does not exceed the rated current of the motor.

Dimensions Unit = mm (in.)

Motor

2D & 3D CAD

Product Name	L1	L2	Mass kg (lb.)	2D CAD
PKP296D45AA	—	—	—	B1240
PKP296D45BA	66 (2.60)	100 (3.94)	1.8 (4.0)	
PKP296D63AA	—	—	—	
PKP296D63BA	—	100 (3.94)	—	B1241
PKP299D45AA	—	—	—	
PKP299D45BA	96 (3.78)	130 (5.12)	2.9 (6.4)	
PKP299D63AA	—	—	—	B1242
PKP299D63BA	—	130 (5.12)	—	
PKP2913D45AA	—	—	—	
PKP2913D45BA	126 (4.96)	160 (6.30)	4 (8.8)	B1242
PKP2913D56AA	—	—	—	
PKP2913D56BA	—	160 (6.30)	—	

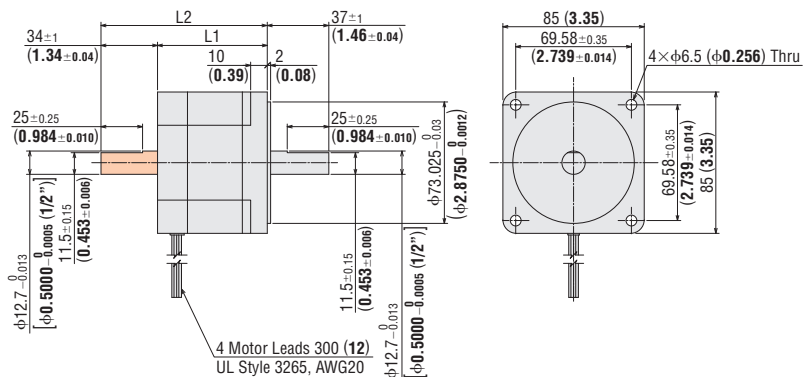

● These dimensions are for double shaft motors.

For single shaft motors, ignore the shaded areas.

Inner Wiring Diagram of Motor

Wiring Diagram No.: Model C⑤

- Refer to page 67 for inner wiring diagram of motor.

Features
Product
Line

Product
Number
Product Line

Standard
Type

High-Resolution
Type

Flat Type

SH
Geared
Type

CS
Geared
Type

General
Specifications/
Inner Wiring
Diagram of Motor

5-Phase
Motors
PKP

Features
Product
Line

Product
Number
Product Line

Standard
Type

High-Resolution
Type

TS
Geared
Type

General
Specifications/
Inner Wiring
Diagram of Motor

Driver for
2-Phase/
5-Phase Motors

Accessories

High-Resolution Type

Frame Size 42 mm (1.65 in.) (Bipolar 4 Lead Wires)

- 20 mm (0.79 in.)
- 28 mm (1.10 in.)
- 35 mm (1.38 in.)
- 42 mm (1.65 in.)
- 50 mm (1.97 in.)
- 51 mm (2.01 in.)
- 56.4 mm (2.22 in.)
- 60 mm (2.36 in.)
- 61 mm (2.40 in.)
- 85 mm (3.35 in.)

Specifications

Product Name	Maximum Holding Torque N·m (oz·in)	Rotor Inertia J: kg·m ² (oz·in ²)	Rated Current A/Phase	Voltage VDC	Winding Resistance Ω/Phase	Inductance mH/Phase	Basic Step Angle	Recommended Driver Product Name*
PKP243MD15□□	0.32 (45)	39×10^{-7} (0.21)	1.5	2.7	1.8	5.1	0.9°	CVD223FBR-K
PKP244MD15□□	0.42 (59)	58×10^{-7} (0.32)		3.2	2.1	6		
PKP245MD15□□	0.61 (86)	78×10^{-7} (0.43)		3	2	6.6		
PKP246MD15□□	0.82 (116)	116×10^{-7} (0.64)		3.9	2.6	9		

● The box □ in the product name indicates the shaft **A** (single shaft) or **B** (double shaft).

* See page 94 for details on the recommended drivers.

Speed – Torque Characteristics (Reference values) fs: Max. Starting Frequency

PKP243MD15A2/ PKP243MD15B2

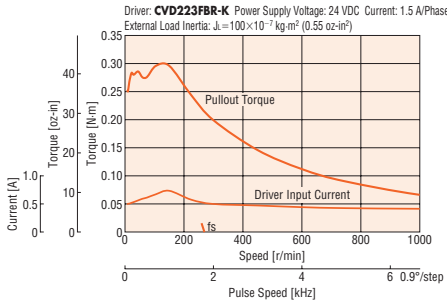

PKP244MD15A2/ PKP244MD15B2

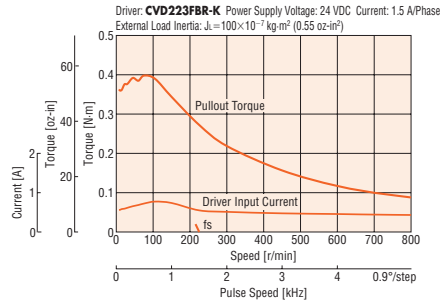

PKP245MD15A2/ PKP245MD15B2

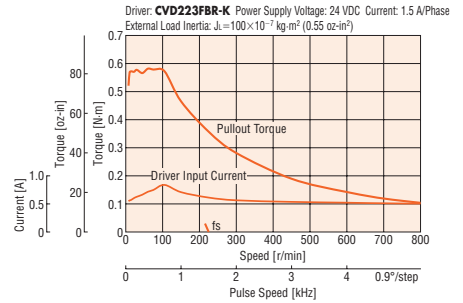

PKP246MD15A2/ PKP246MD15B2

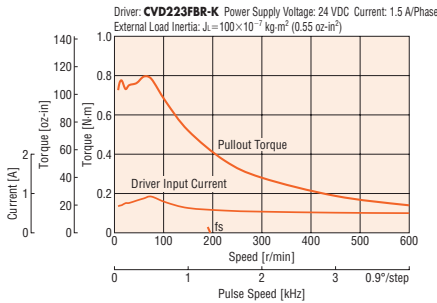

Note

- Data for the speed – torque characteristics is based on Oriental Motor's internal measurement conditions. If the conditions are changed, the characteristics may also change as a result.
- The data in the speed – torque characteristics represents the use of an external load inertia.
- Depending on the driving conditions, a considerable amount of heat may be generated by the motor. Be sure to keep the temperature of the motor case under 100°C (212°F).
- Set the current of the driver so that it does not exceed the rated current of the motor.

Dimensions Unit: mm (in.)

Motor

2D & 3D CAD

Product Name	L1	L2	Mass kg (lb.)	2D CAD
PKP243MD15A2	33	—	0.23	B1260
PKP243MD15B2	(1.30)	48 (1.89)	(0.51)	
PKP244MD15A2	39	—	0.3	B1261
PKP244MD15B2	(1.54)	54 (2.13)	(0.66)	
PKP245MD15A2	47	—	0.37	B1262
PKP245MD15B2	(1.85)	62 (2.44)	(0.81)	
PKP246MD15A2	59	—	0.5	B1263
PKP246MD15B2	(2.32)	74 (2.91)	(1.1)	

Applicable Connector

Connector Housing: MDF97-5S-3.5C (HIROSE ELECTRIC CO., LTD.)
Contact: MDF97-22SC (HIROSE ELECTRIC CO., LTD.)
Crimp Tool: HT801/MDF97-22S (HIROSE ELECTRIC CO., LTD.)

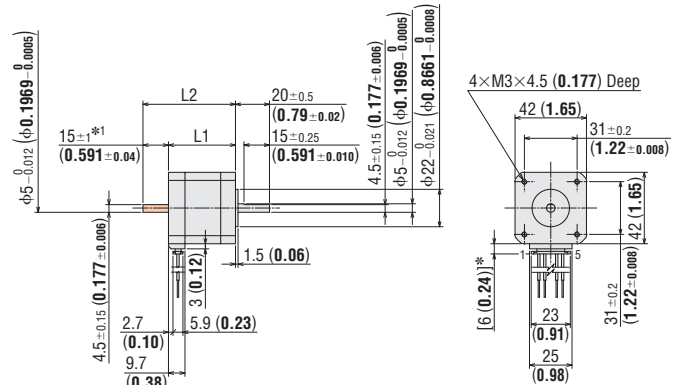

*1 The length of machining on the double shaft product is 15±0.25 (0.591±0.010).

*2 With connection cable

● These dimensions are for double shaft products.
For single shaft products, ignore the shaded areas.

Connection Cables (Sold separately)

Motor Connection Cable

Product Name	Length L [m (ft.)]
LC2B06E	0.6 (2)
LC2B10E	1 (3.3)

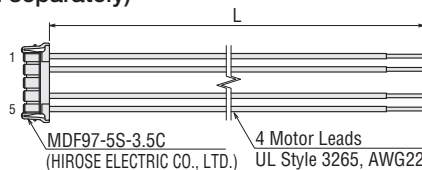

Inner Wiring Diagram of Motor

Wiring Diagram No.: Model A①

● Refer to page 67 for inner wiring diagram of motor.

High-Resolution Type with Encoder Frame Size 42 mm (1.65 in.) (Bipolar 4 Lead Wires)

2-Phase Motors
PKP

Specifications

Product Name	Maximum Holding Torque N·m (oz·in)	Rotor Inertia J: kg·m ² (oz·in ²)	Rated Current A/Phase	Voltage VDC	Winding Resistance Ω/Phase	Inductance mH/Phase	Basic Step Angle	Recommended Driver Product Name*
PKP243MD15A2-R2F ■	0.32 (45)	39 × 10 ⁻⁷ (0.21)	1.5	2.7	1.8	5.1	0.9°	CVD223FBR-K
PKP244MD15A2-R2F ■	0.42 (59)	58 × 10 ⁻⁷ (0.32)		3.2	2.1	6		
PKP245MD15A2-R2F ■	0.61 (86)	78 × 10 ⁻⁷ (0.43)		3	2	6.6		
PKP246MD15A2-R2F ■	0.82 (116)	116 × 10 ⁻⁷ (0.64)		3.9	2.6	9		

- A code L (line driver output) indicating the encoder output circuit type is entered where the box ■ is located within the product name. The voltage output type will have no "■" in the product name.
- See page 64 for encoder specifications.

*See page 94 for details on the recommended drivers.

Speed – Torque Characteristics (Reference values) fs: Max. Starting Frequency

PKP243MD15A2-R2FL
PKP243MD15A2-R2F

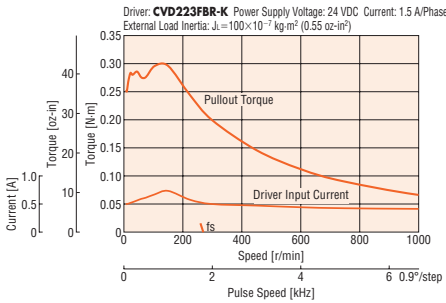

PKP244MD15A2-R2FL
PKP244MD15A2-R2F

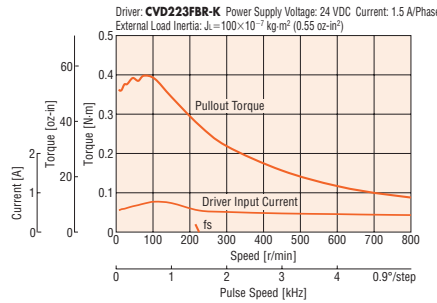

PKP245MD15A2-R2FL
PKP245MD15A2-R2F

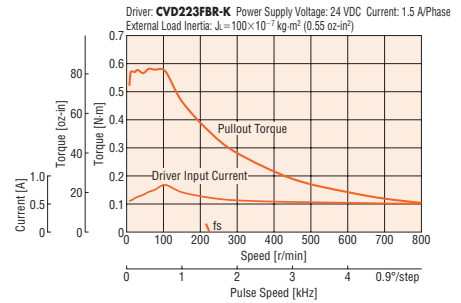

PKP246MD15A2-R2FL
PKP246MD15A2-R2F

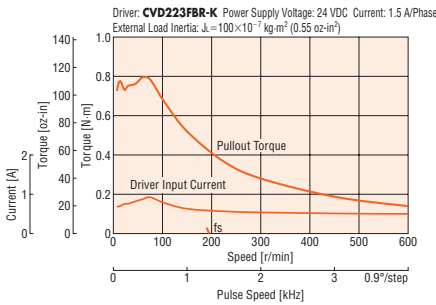

Note

- Data for the speed – torque characteristics is based on Oriental Motor's internal measurement conditions. If the conditions are changed, the characteristics may also change as a result.
- The data in the speed – torque characteristics represents the use of an external load inertia.
- Depending on the driving conditions, a considerable amount of heat may be generated by the motor. To protect the encoder, keep the motor case temperature at 85°C (185°F) max.
- Set the current of the driver so that it does not exceed the rated current of the motor.

Dimensions Unit: mm (in.)

Motor

2D & 3D CAD

Product Name	L	Mass kg (lb.)	2D CAD
PKP243MD15A2-R2F ■	46.5 (1.83)	0.23 (0.51)	B1321
PKP244MD15A2-R2F ■	52.5 (2.07)	0.3 (0.66)	B1322
PKP245MD15A2-R2F ■	60.5 (2.38)	0.37 (0.81)	B1323
PKP246MD15A2-R2F ■	72.5 (2.85)	0.5 (1.1)	B1324

- A code L (line driver output) indicating the encoder output circuit type is entered where the box ■ is located within the product name. The voltage output type will have no "■" in the product name.

Applicable Connector

	Motor (Hirose Electric Co., Ltd.)	Encoder (Molex)
Connector Housing	MDF97-5S-3.5C	51021-0800
Contact	MDF97-22SC	50079-8100
Crimp Tool	HT801/MDF97-22S	57177-5000

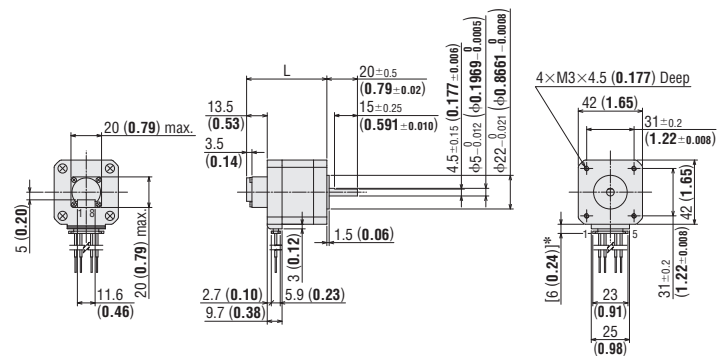

Connection Cables (Sold separately)

Motor Connection Cable

Product Name	Length L [m (ft.)]
LC2B06E	0.6 (2)
LC2B10E	1 (3.3)

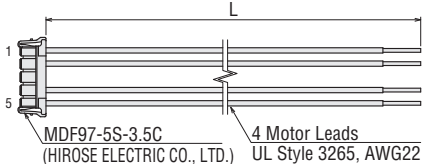

Encoder Connection Cable

Encoder Output Circuit Type	Product Name	Length L [m (ft.)]
Line Driver Output Type	LCE08A-006	0.6 (2)
Voltage Output Type	LCE05A-006	

•LCE08A-006

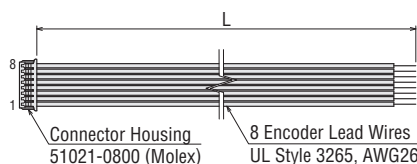

•LCE05A-006

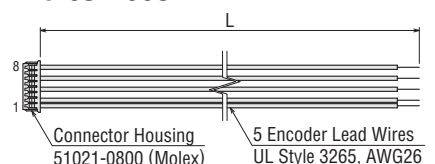

Inner Wiring Diagram of Motor

Wiring Diagram No.: Model A①

- Refer to page 67 for inner wiring diagram of motor.

Features
Product Line

Product Number
Product Line

Standard Type

High-Resolution Type

Flat Type

SH Geared Type

CS Geared Type

General Specifications/
Inner Wiring Diagram of Motor

5-Phase Motors
PKP

Features
Product Line

Product Number
Product Line

Standard Type

High-Resolution Type

TS Geared Type

General Specifications/
Inner Wiring Diagram of Motor

Driver for
2-Phase/
5-Phase Motors

Accessories

High-Resolution Type with Electromagnetic Brake Frame Size 42 mm (1.65 in.) (Bipolar 4 Lead Wires)

20 mm
(0.79 in.)

28 mm
(1.10 in.)

35 mm
(1.38 in.)

42 mm
(1.65 in.)

50 mm
(1.97 in.)
51 mm
(2.01 in.)

56.4 mm
(2.22 in.)

60 mm
(2.36 in.)
61 mm
(2.40 in.)

85 mm
(3.35 in.)

Specifications

Product Name	Maximum Holding Torque N·m (oz·in)	Rotor Inertia J: kg·m ² (oz·in ²)	Rated Current A/Phase	Voltage VDC	Winding Resistance Ω/Phase	Inductance mH/Phase	Basic Step Angle	Electromagnetic Brake Static Friction Torque* N·m (oz·in)
PKP243MD15M	0.30 (42)	48×10^{-7} (0.26)*	1.5	2.85	1.9	6.6	0.9°	0.3 (42)
PKP244MD15M	0.42 (59)	69×10^{-7} (0.38)*		3.9	2.6	7.6		

● See page 64 for electromagnetic brake specifications.

*The inertia of the electromagnetic brake is included in the value.

Speed – Torque Characteristics (Reference values) fs: Max. Starting Frequency

PKP243MD15M

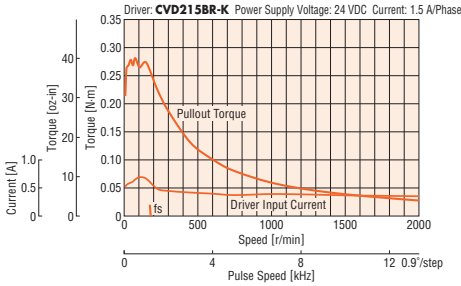

PKP244MD15M

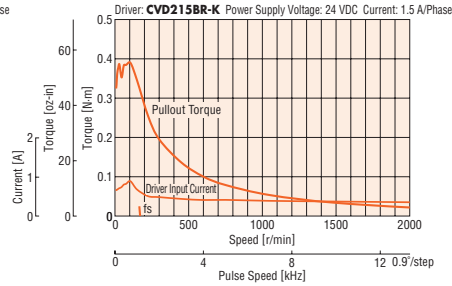

Note

- Data for the speed – torque characteristics is based on Oriental Motor's internal measurement conditions. If the conditions are changed, the characteristics may also change as a result.
- Depending on the driving conditions, a considerable amount of heat may be generated by the motor. Be sure to keep the motor case temperature at 100°C (212°F) max.
- Set the current of the driver so that it does not exceed the rated current of the motor.

Dimensions Unit: mm (in.)

Motor

2D & 3D CAD

Product Name	L	Mass kg (lb.)	2D CAD
PKP243MD15M	67 (2.64)	0.36 (0.79)	B1136
PKP244MD15M	73 (2.87)	0.41 (0.90)	B1137

- Applicable Connector (Molex)
Connector Housing: 51103-0600
Contact: 50351-8100
Crimp Tool: 57295-5000

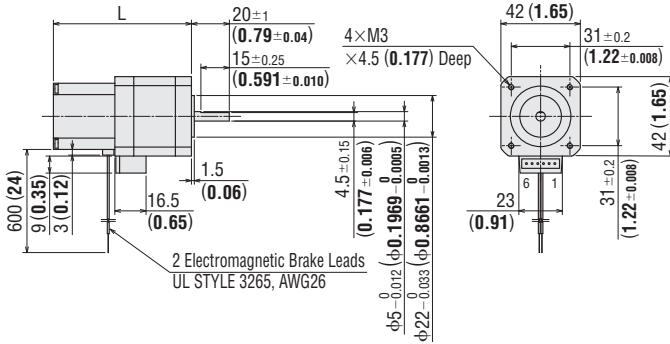

Connection Cables (Sold separately)

Motor Connection Cable

Product Name	Length L [m (ft.)]
LC2B06B	0.6 (2)
LC2B10B	1 (3.3)

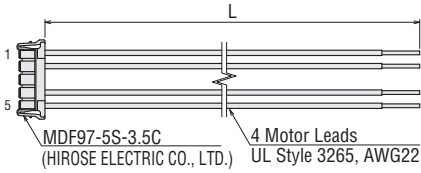

Inner Wiring Diagram of Motor

Wiring Diagram No.: Model B③

- Refer to page 67 for inner wiring diagram of motor.

2-Phase
Motors
PKP

Features
Product
Line

Product
Number
Product Line

Standard
Type

High-
Resolution
Type

Flat Type

SH
Geared
Type

CS
Geared
Type

General
Specifications/
Inner Wiring
Diagram of Motor

5-Phase
Motors
PKP

Features
Product
Line

Product
Number
Product Line

Standard
Type

High-
Resolution
Type

TS
Geared
Type

General
Specifications/
Inner Wiring
Diagram of Motor

Driver for
2-Phase/
5-Phase Motors

Accessories

High-Resolution Type Frame Size 56.4 mm (2.22 in.) (Bipolar 4 Lead Wires)

20 mm (0.79 in.)

28 mm (1.10 in.)

35 mm (1.38 in.)

42 mm (1.65 in.)

50 mm (1.97 in.)
51 mm (2.01 in.)

56.4 mm (2.22 in.)

60 mm (2.36 in.)
61 mm (2.40 in.)

85 mm (3.35 in.)

Specifications

Product Name	Maximum Holding Torque N·m (oz·in)	Rotor Inertia J: kg·m ² (oz·in ²)	Rated Current A/Phase	Voltage VDC	Winding Resistance Ω/Phase	Inductance mH/Phase	Basic Step Angle	Recommended Driver Product Name*
PKP264MD28□2	0.7 (99)	150×10 ⁻⁷ (0.82)	2.8	2	0.73	2.1	0.9°	CVD228BR-K
PKP266MD28□2	1.4 (198)	310×10 ⁻⁷ (1.7)		1.8	0.65	3		
PKP268MD28□2	2.3 (320)	520×10 ⁻⁷ (2.8)		2.7	0.97	4.7		

● The box □ in the product name indicates the shaft **A** (single shaft) or **B** (double shaft).

*See page 94 for details on the recommended drivers.

Speed – Torque Characteristics (Reference Values) fs: Max. Starting Frequency

PKP264MD28A2/ PKP264MD28B2

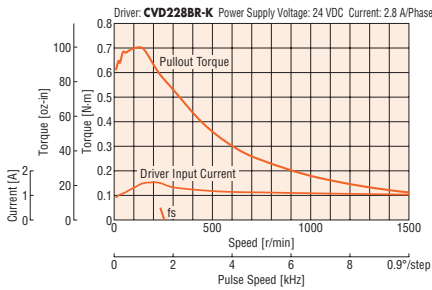

PKP266MD28A2/ PKP266MD28B2

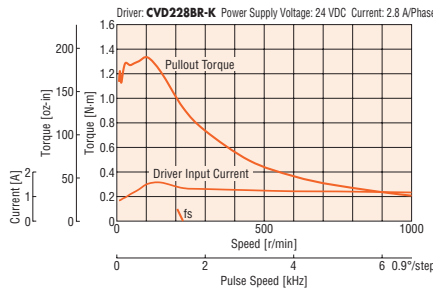

PKP268MD28A2/ PKP268MD28B2

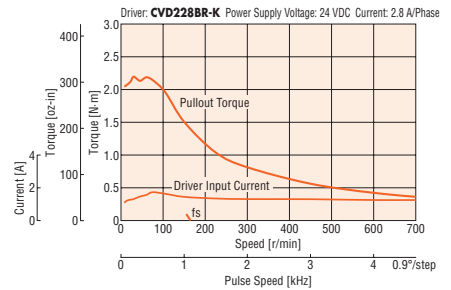

Note

- Data for the speed – torque characteristics is based on Oriental Motor's internal measurement conditions. If the conditions are changed, the characteristics may also change as a result.
- Depending on the driving conditions, a considerable amount of heat may be generated by the motor. Be sure to keep the temperature of the motor case under 100°C (212°F).
- Set the current of the driver so that it does not exceed the rated current of the motor.

Dimensions Unit: mm (in.)

Motor

2D & 3D CAD

Product Name	L1	L2	Mass kg (lb.)	2D CAD
PKP264MD28A2	39	—	0.45	B1249
PKP264MD28B2	(1.54)	62 (2.44)	(0.99)	
PKP266MD28A2	54	—	0.7	B1250
PKP266MD28B2	(2.13)	77 (3.03)	(1.54)	
PKP268MD28A2	76	—	1.1	B1251
PKP268MD28B2	(2.99)	99 (3.90)	(2.4)	

Applicable Connector

Connector Housing: MDF97-5S-3.5C (HIROSE ELECTRIC CO., LTD.)
Contact: MDF97-22SC (HIROSE ELECTRIC CO., LTD.)
Crimp Tool: HT801/MDF97-22S (HIROSE ELECTRIC CO., LTD.)

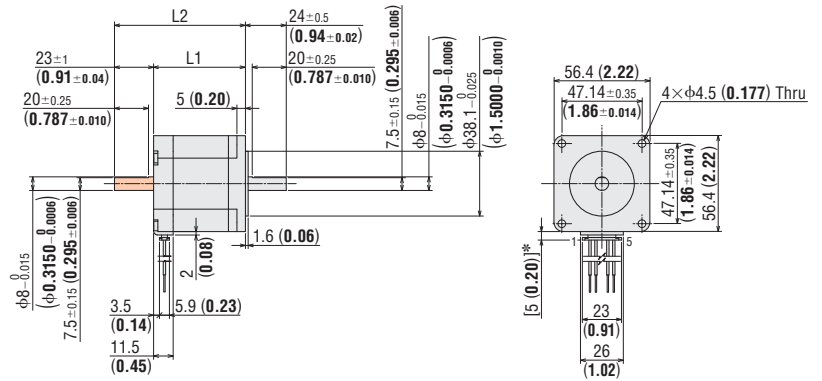

*With connection cable

- These dimensions are for double shaft products.
- For single shaft products, ignore the shaded areas.

Connection Cables (Sold separately)

Motor Connection Cable

Product Name	Length L [m (ft.)]
LC2B06E	0.6 (2)
LC2B10E	1 (3.3)

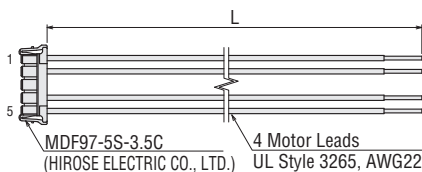

Inner Wiring Diagram of Motor

Wiring Diagram No.: Model A①

● Refer to page 67 for inner wiring diagram of motor.

High-Resolution Type with Encoder Frame Size 56.4 mm (2.22 in.) (Bipolar 4 Lead Wires)

2-Phase Motors
PKP

Features Product Line

Product Number Product Line

Standard Type

High-Resolution Type

Flat Type

SH Geared Type

CS Geared Type

General Specifications/ Inner Wiring Diagram of Motor

5-Phase Motors PKP

Features Product Line

Product Number Product Line

Standard Type

High-Resolution Type

TS Geared Type

General Specifications/ Inner Wiring Diagram of Motor

Driver for 2-Phase/ 5-Phase Motors

Accessories

Specifications

Product Name	Maximum Holding Torque N·m (oz·in)	Rotor Inertia J: kg·m ² (oz·in ²)	Rated Current A/Phase	Voltage VDC	Winding Resistance Ω/Phase	Inductance mH/Phase	Basic Step Angle	Recommended Driver Product Name*
PKP264MD28A2-R2F	0.7 (99)	150×10 ⁻⁷ (0.82)	2.8	2	0.73	2.1	0.9°	CVD228BR-K
PKP266MD28A2-R2F	1.4 (198)	310×10 ⁻⁷ (1.7)		1.8	0.65	3		
PKP268MD28A2-R2F	2.3 (320)	520×10 ⁻⁷ (2.8)		2.7	0.97	4.7		

● A code L (line driver output) indicating the encoder output circuit type is entered where the box ■ is located within the product name. The voltage output type will have no "■" in the product name.

● See page 64 for encoder specifications.

*See page 94 for details on the recommended drivers.

Speed – Torque Characteristics (Reference Values) fs: Max. Starting Frequency

PKP264MD28A2-R2FL
PKP264MD28A2-R2F

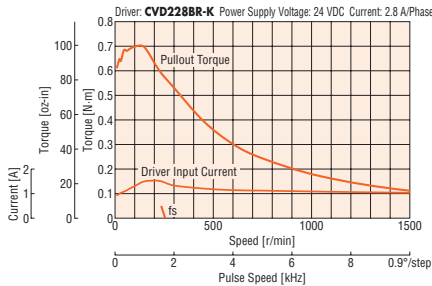

PKP266MD28A2-R2FL
PKP266MD28A2-R2F

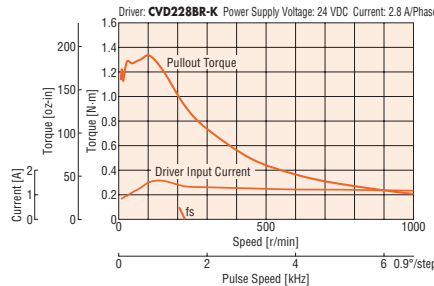

PKP268MD28A2-R2FL
PKP268MD28A2-R2F

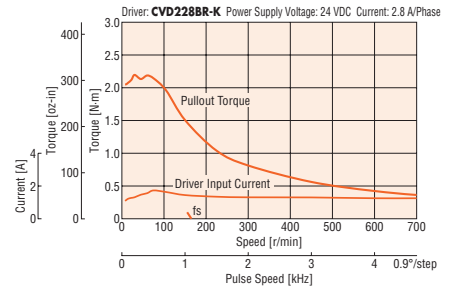

Note

- Data for the speed – torque characteristics is based on Oriental Motor's internal measurement conditions. If the conditions are changed, the characteristics may also change as a result.
- Depending on the driving conditions, a considerable amount of heat may be generated by the motor. To protect the encoder, keep the motor case temperature at 85°C (185°F) max.
- Set the current of the driver so that it does not exceed the rated current of the motor.

Dimensions Unit: mm (in.)

Motor

2D & 3D CAD

Product Name	L	Mass kg (lb.)	2D CAD
PKP264MD28A2-R2F	55.5 (2.19)	0.45 (0.99)	B1325
PKP266MD28A2-R2F	70.5 (2.78)	0.7 (1.54)	B1326
PKP268MD28A2-R2F	92.5 (3.64)	1.1 (2.4)	B1327

● A code L (line driver output) indicating the encoder output circuit type is entered where the box ■ is located within the product name. The voltage output type will have no "■" in the product name.

Applicable Connector

	Motor (Hirose Electric Co., Ltd.)	Encoder (Molex)
Connector Housing	MDF97-5S-3.5C	51021-0800
Contact	MDF97-22SC	50079-8100
Crimp Tool	HT801/MDF97-22S	57177-5000

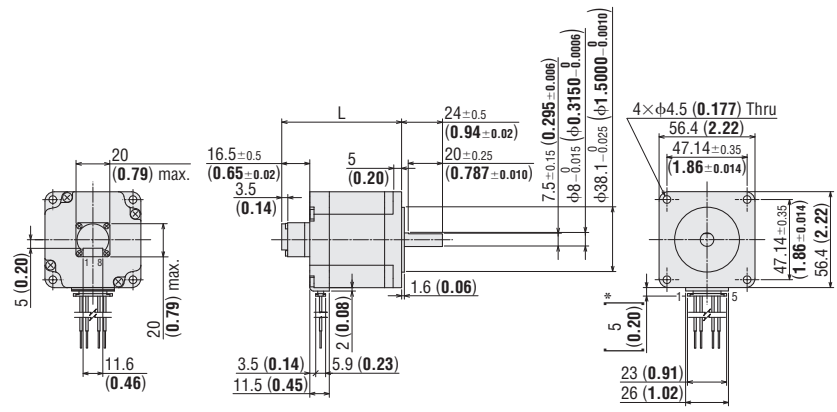

*With connection cable

Connection Cables (Sold separately)

Motor Connection Cable

Product Name	Length L [m (ft.)]
LC2B06E	0.6 (2)
LC2B10E	1 (3.3)

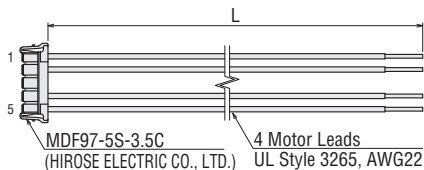

Encoder Connection Cable

Product Name	Length L [m (ft.)]
LCE08A-006	0.6 (2)

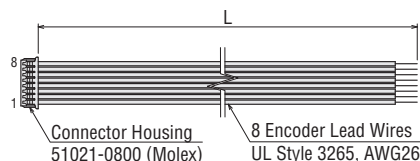

Inner Wiring Diagram of Motor

Wiring Diagram No.: Model A①

● Refer to page 67 for inner wiring diagram of motor.

Motor
Frame Size

20 mm
(0.79 in.)

28 mm
(1.10 in.)

35 mm
(1.38 in.)

42 mm
(1.65 in.)

50 mm
(1.97 in.)
51 mm
(2.01 in.)

56.4 mm
(2.22 in.)

60 mm
(2.36 in.)
61 mm
(2.40 in.)

85 mm
(3.35 in.)

High-Resolution Type with Electromagnetic Brake Frame Size 56.4 mm (2.22 in.) (Bipolar 4 lead wires)

Specifications

Product Name	Maximum Holding Torque N·m (oz·in)	Rotor Inertia J: kg·m ² (oz·in ²)	Rated Current A/Phase	Voltage VDC	Winding Resistance Ω/Phase	Inductance mH/Phase	Basic Step Angle	Electricmagnetic Brake Static Friction Torque N·m (oz·in)
PKP264MD28M	0.6 (85)	270×10^{-7} (1.48)*	2.8	2	0.73	2.1	0.9°	1.5 (213)
PKP266MD28M	1.32 (187)	440×10^{-7} (2.4)*		2.8	1	3.9		
PKP268MD28M	2.23 (325)	640×10^{-7} (3.5)*		3.4	1.23	5.6		

● See page 64 for electromagnetic brake specifications.

*The Inertia of the electromagnetic brake is included in the value.

Speed – Torque Characteristics (Reference Values) fs: Max. Starting Frequency

PKP264MD28M

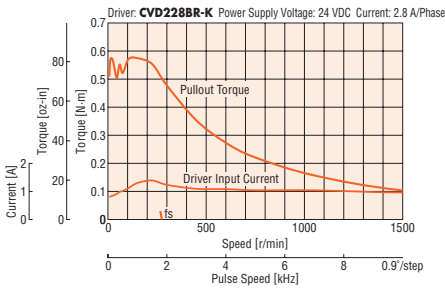

PKP266MD28M

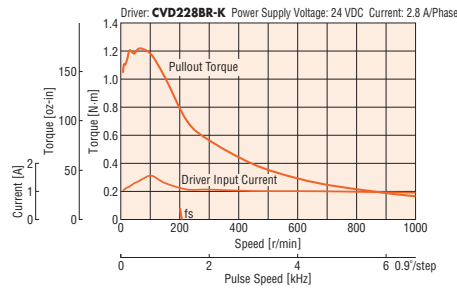

PKP268MD28M

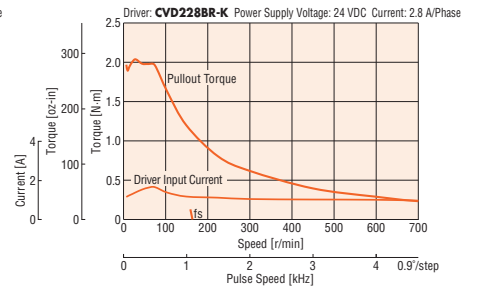

Note

- Data for the speed – torque characteristics is based on Oriental Motor's internal measurement conditions. If the conditions are changed, the characteristics may also change as a result.
- Depending on the driving conditions, a considerable amount of heat may be generated by the motor. Be sure to keep the motor case temperature at 100°C (212°F) max.
- Set the current of the driver so that it does not exceed the rated current of the motor.

Dimensions Unit: mm (in.)

● Motor

2D & 3D CAD

Product Name	L	Mass kg (lb.)	2D CAD
PKP264MD28M	75.5 (2.97)	0.76 (1.67)	B1140
PKP266MD28M	90.5 (3.56)	1.03 (2.3)	B1141
PKP268MD28M	112.5 (4.43)	1.4 (3.1)	B1142

- Applicable Connector (Molex)
 - Connector Housing: 51067-0600
 - Contact: 50217-9101
 - Crimp Tool: 57189-5000
 - 57190-5000

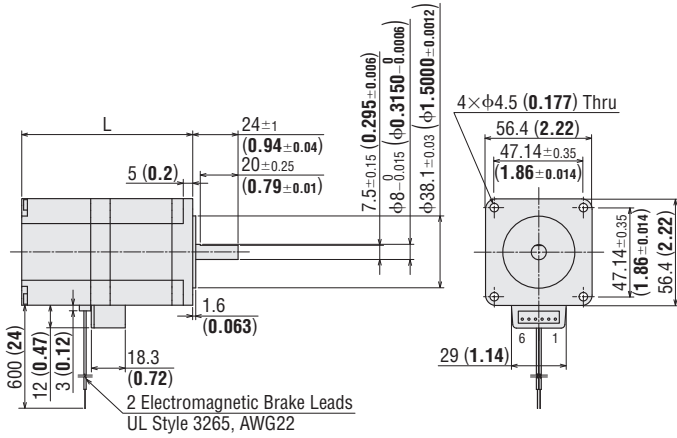

● Connection Cable (Sold separately)

◇ Motor Connection Cable

Product Name	Length L [m (ft.)]
LC2B06C	0.6 (2)
LC2B10C	1 (3.3)

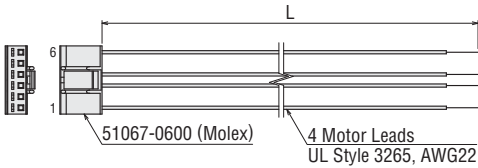

Inner Wiring Diagram of Motor

Wiring Diagram No.: Model B③

- Refer to page 67 for inner wiring diagram of motor.

2-Phase
Motors
PKP

Features
Product
Line

Product
Number
Product Line

Standard
Type

High-
Resolution
Type

Flat Type

SH
Geared
Type

CS
Geared
Type

General
Specifications/
Inner Wiring
Diagram of Motor

5-Phase
Motors
PKP

Features
Product
Line

Product
Number
Product Line

Standard
Type

High-
Resolution
Type

TS
Geared
Type

General
Specifications/
Inner Wiring
Diagram of Motor

Driver for
2-Phase/
5-Phase Motors

Accessories

Flat Type

Frame Size 42 mm (1.65 in.) (Bipolar 4 Lead Wires)

20 mm
(0.79 in.)

28 mm
(1.10 in.)

35 mm
(1.38 in.)

42 mm
(1.65 in.)

50 mm
(1.97 in.)
51 mm
(2.01 in.)

56.4 mm
(2.22 in.)

60 mm
(2.36 in.)
61 mm
(2.40 in.)

85 mm
(3.35 in.)

Specifications

Product Name	Maximum Holding Torque N·m (oz·in)	Rotor Inertia J: kg·m ² (oz·in ²)	Rated Current A/Phase	Voltage VDC	Winding Resistance Ω/Phase	Inductance mH/Phase	Basic Step Angle	Recommended Driver Product Name*
PKP242D23A2	0.1 (14)	13×10^{-7} (0.071)	2.3	1.4	0.61	0.53	1.8°	CVD223FBR-K

*See page 94 for details on the recommended drivers.

Speed – Torque Characteristics (Reference Values) fs: Max. Starting Frequency

PKP242D23A2

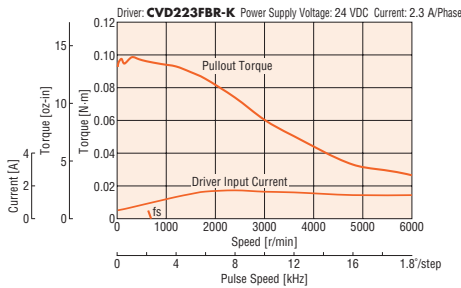

Note

- Data for the speed – torque characteristics is based on Oriental Motor's internal measurement conditions. If the conditions are changed, the characteristics may also change as a result.
- Depending on the driving conditions, a considerable amount of heat may be generated by the motor. Be sure to keep the motor case temperature at 100°C (212°F) max.
- Set the current of the driver so that it does not exceed the rated current of the motor.

Dimensions Unit: mm (in.)

Motor

2D & 3D CAD

Product Name	Mass kg (lb.)	2D CAD
PKP242D23A2	0.11 (0.24)	B1355

Applicable Connector

Connector Housing: MDF97-5S-3.5C (HIROSE ELECTRIC CO., LTD.)

Contact: MDF97-22SC (HIROSE ELECTRIC CO., LTD.)

Crimp Tool: HT801/MDF97-22S (HIROSE ELECTRIC CO., LTD.)

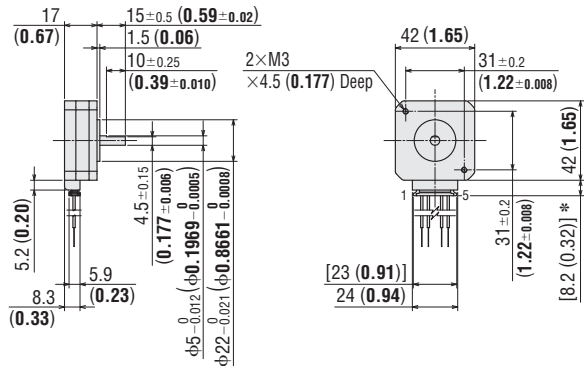

*With connection cable

Connection Cable (Sold separately)

Motor Connection Cable

Product Name	Length L [m (ft.)]
LC2B06E	0.6 (2)
LC2B10E	1 (3.3)

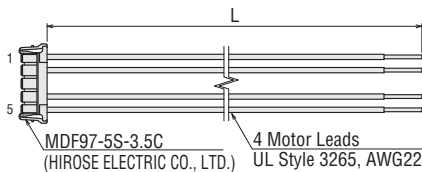

Inner Wiring Diagram of Motor

Wiring Diagram No.: Model A①

- Refer to page 67 for inner wiring diagram of motor.

Flat Type

Frame Size 60 mm (2.36 in.) (Bipolar 4 Lead Wires)

2-Phase Motors
PKP

Specifications

Product Name	Maximum Holding Torque N·m (oz·in)	Rotor Inertia J: kg·m ² (oz·in ²)	Rated Current A/Phase	Voltage VDC	Winding Resistance Ω/Phase	Inductance mH/Phase	Basic Step Angle	Recommended Driver Product Name*
PKP262FD15AW	0.18 (25)	68×10^{-7} (0.37)	1.5	2.25	1.5	1.4	1.8°	CVD215BR-K

*See page 94 for details on the recommended drivers.

Speed – Torque Characteristics (Reference Values) fs: Max. Starting Frequency

PKP262FD15AW

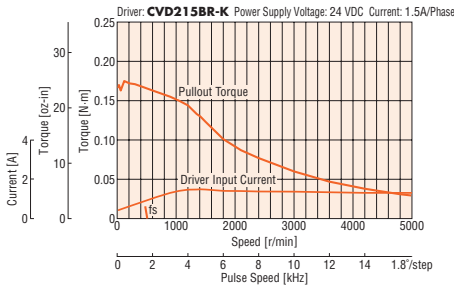

Note

- Data for the speed – torque characteristics is based on Oriental Motor's internal measurement conditions. If the conditions are changed, the characteristics may also change as a result.
- Depending on the driving conditions, a considerable amount of heat may be generated by the motor. Be sure to keep the motor case temperature at 100°C (212°F) max.
- Set the current of the driver so that it does not exceed the rated current of the motor.

Dimensions Unit: mm (in.)

Motor

2D & 3D CAD

Product Name	Mass kg (lb.)	2D CAD
PKP262FD15AW	0.2 (0.44)	B1170

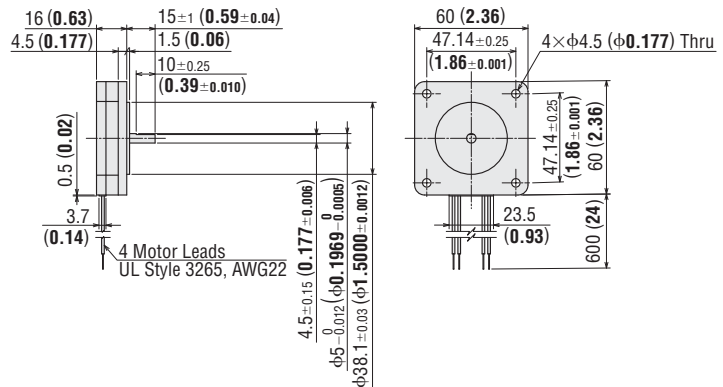

Inner Wiring Diagram of Motor

Wiring Diagram No.: Model C⑤

- Refer to page 67 for inner wiring diagram of motor.

Features
Product Line

Product Number
Product Line

Standard Type

High-Resolution Type

Flat Type

SH Geared Type

CS Geared Type

General Specifications/
Inner Wiring Diagram of Motor

5-Phase Motors
PKP

Features
Product Line

Product Number
Product Line

Standard Type

High-Resolution Type

TS Geared Type

General Specifications/
Inner Wiring Diagram of Motor

Driver for
2-Phase/
5-Phase Motors

Accessories

Flat Type with Harmonic Gear Frame Size 51 mm (2.01 in.) (Bipolar 4 Lead Wires)

20 mm (0.79 in.)

28 mm (1.10 in.)

35 mm (1.38 in.)

42 mm (1.65 in.)

50 mm (1.97 in.)
51 mm (2.01 in.)
51 mm (2.01 in.)

56.4 mm (2.22 in.)

60 mm (2.36 in.)
61 mm (2.40 in.)

85 mm (3.35 in.)

Specifications

Product Name	Maximum Holding Torque N·m (lb·in)	Rotor Inertia J: kg·m ² (oz·in ²)	Rated Current A/Phase	Voltage VDC	Winding Resistance Ω/Phase	Inductance mH/Phase	Basic Step Angle	Gear Ratio	Permissible Torque N·m (lb·in)	Maximum Instantaneous Torque N·m (lb·in)	Lost Motion (Load Torque) arcmin	Speed Range r/min	Recommended Driver Product Name*
PKP242D23A2-H50	1.8 (15.9)	17×10 ⁻⁷ (0.093)	2.3	1.4	0.61	0.53	0.036°	50	1.8 (15.9)	3.3 (29)	1.5 max. (±0.59 N·m)	0 - 70	CVD223FBR-K
PKP242D23A2-H100	2.4 (21)						0.018°	100	2.4 (21)	4.8 (42)	1.5 max. (±0.78 N·m)	0 - 35	

*See page 94 for details on the recommended drivers.

Note

- The rotor inertia represents a sum of the inertia of the harmonic gear converted to motor shaft values.

Speed – Torque Characteristics (Reference Values) fs: Max. Starting Frequency

PKP242D23A2-H50

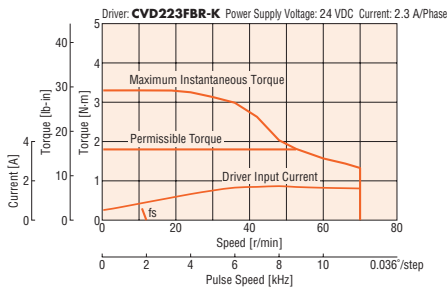

PKP242D23A2-H100

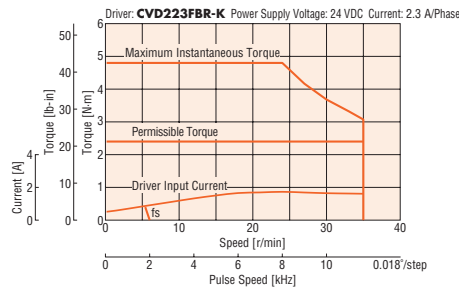

Note

- Data for the speed – torque characteristics is based on Oriental Motor's internal measurement conditions. If the conditions are changed, the characteristics may also change as a result.
- The speed – torque characteristics is data when the gear case temperature is at 25 to 30°C (77 to 86°F). As the temperature decreases, the viscosity of the grease in the gear increases and the torque decreases.
- In order to prevent deterioration of the gear grease, keep the temperature of the gear case at 70°C (158°F) max.
- Set the current of the driver so that it does not exceed the rated current of the motor.

Dimensions Unit: mm (in.)

Motor

2D & 3D CAD

Product Name	Mass kg (lb.)	2D CAD
PKP242D23A2-H50	0.32 (0.70)	B1356
PKP242D23A2-H100		

Applicable Connector

Connector Housing: MDF97-5S-3.5C (HIROSE ELECTRIC CO., LTD.)
Contact: MDF97-22SC (HIROSE ELECTRIC CO., LTD.)
Crimp Tool: HT801/MDF97-22S (HIROSE ELECTRIC CO., LTD.)

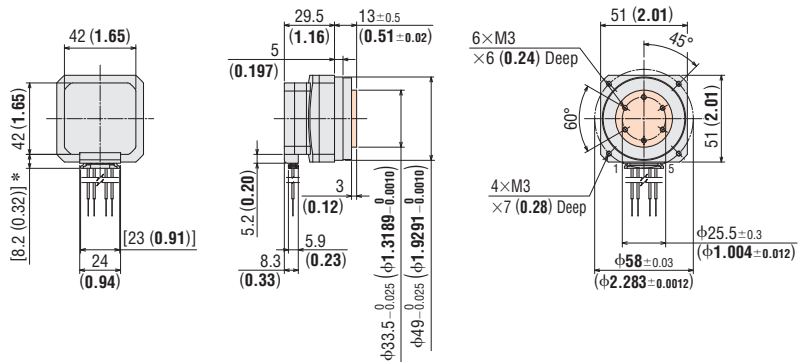

● The shaded areas are rotating parts.
*With connection cable

Connection Cable (Sold separately)

Motor Connection Cable

Product Name	Length L [m (ft.)]
LC2B06E	0.6 (2)
LC2B10E	1 (3.3)

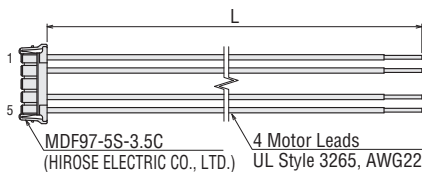

Inner Wiring Diagram of Motor

Wiring Diagram No.: Model A①

- Refer to page 67 for inner wiring diagram of motor.

Flat Type with Harmonic Gear Frame Size 61 mm (2.40 in.) (Bipolar 4 Lead Wires)

2-Phase Motors
PKP

Specifications

Product Name	Maximum Holding Torque N-m (lb-in)	Rotor Inertia J: kg·m ² (oz-in ²)	Rated Current A/Phase	Voltage VDC	Winding Resistance Ω/Phase	Inductance mH/Phase	Basic Step Angle	Gear Ratio	Permissible Torque N-m (lb-in)	Maximum Instantaneous Torque N-m (lb-in)	Lost Motion (Load Torque) arcmin	Speed Range r/min	Recommended Driver Product Name*
PKP262FD15AW-H50S	3.5 (30)	83×10 ⁻⁷ (0.093)	1.5	1.65	1.1	0.8	0.036°	50	3.5 (30)	*	1.5 max. (±0.17 N·m)	0 to 70	CVD215BR-K
PKP262FD15AW-H100S	5 (44)						0.018°	100	5 (44)	*	1.5 max. (±0.25 N·m)	0 to 35	

*For the output torque of the geared motor, refer to the speed-torque characteristics.

*See page 94 for details on the recommended drivers.

Note

● The rotor inertia represents a sum of the inertia of the harmonic gear converted to motor shaft values.

Features
Product Line

Product Number
Product Line

Standard Type

High-Resolution Type

Flat Type

SH Geared Type

CS Geared Type

General Specifications/
Inner Wiring Diagram of Motor

Speed – Torque Characteristics (Reference Values) f_s : Max. Starting Frequency

PKP262FD15AW-H50S

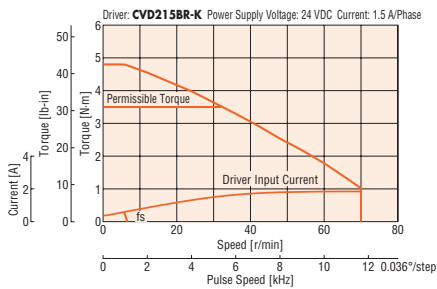

PKP262FD15AW-H100S

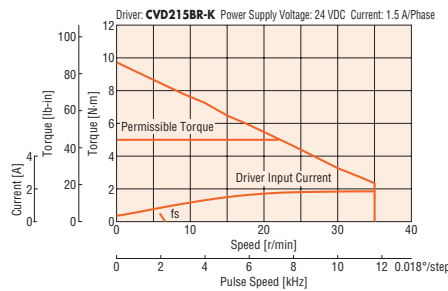

Note

- Data for the speed – torque characteristics is based on Oriental Motor's internal measurement conditions. If the conditions are changed, the characteristics may also change as a result.
- The speed – torque characteristics is data when the gear case temperature is at 25 to 30°C (77 to 86°F). As the temperature decreases, the viscosity of the grease in the gear increases and the torque decreases.
- In order to prevent deterioration of the gear grease, keep the temperature of the gear case at 70°C (158°F) max.
- Set the current of the driver so that it does not exceed the rated current of the motor.

5-Phase Motors
PKP

Features
Product Line

Product Number
Product Line

Standard Type

High-Resolution Type

TS Geared Type

General Specifications/
Inner Wiring Diagram of Motor

Driver for
2-Phase/
5-Phase Motors

Dimensions Unit: mm (in.)

Motor

2D & 3D CAD

Product Name	Mass kg (lb.)	2D CAD
PKP262FD15AW-H50S	0.54 (1.19)	B1451
PKP262FD15AW-H100S		

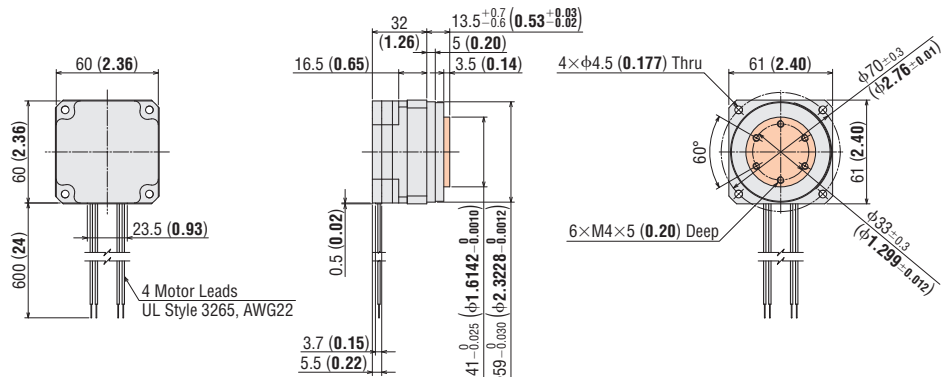

● shaded areas are rotating parts.

Inner Wiring Diagram of Motor

Wiring Diagram No.: Model C⑤

● Refer to page 67 for inner wiring diagram of motor.

Accessories

SH Geared Type

Frame Size 28 mm (1.10 in.) (Bipolar 4 Lead Wires)

20 mm
(0.79 in.)

28 mm
(1.10 in.)

35 mm
(1.38 in.)

42 mm
(1.65 in.)

50 mm
(1.97 in.)
51 mm
(2.01 in.)

56.4 mm
(2.22 in.)

60 mm
(2.36 in.)
61 mm
(2.40 in.)

85 mm
(3.35 in.)

Specifications

Product Name	Maximum Holding Torque N·m (oz·in)	Rotor Inertia J: kg·m ² (oz·in ²)	Rated Current A/Phase	Voltage VDC	Winding Resistance Ω/Phase	Inductance mH/Phase	Basic Step Angle	Gear Ratio	Permissible Torque N·m (oz·in)	Speed Range r/min	Backlash arcmin	Recommended Driver Product Name*
PKP223D15□-SG7.2	0.3 (42)	9×10 ⁻⁷ (0.049)	1.5	1.8	1.2	0.74	0.25°	7.2	0.3 (42)	0 - 416	90 (1.5°)	CVD215BR-K
PKP223D15□-SG9							0.2°	9		0 - 333		
PKP223D15□-SG10							0.18°	10		0 - 300		
PKP223D15□-SG18							0.1°	18		0 - 166		
PKP223D15□-SG36							0.05°	36		0 - 83		

● The box □ in the product name indicates the shaft **A** (single shaft) or **B** (double shaft).

*See page 94 for details on the recommended drivers.

Speed – Torque Characteristics (Reference Values) fs: Max. Starting Frequency

PKP223D15A-SG7.2/PKP223D15B-SG7.2

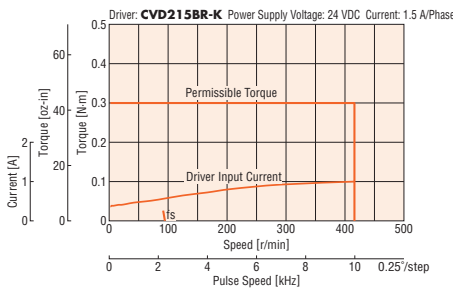

PKP223D15A-SG9/PKP223D15B-SG9

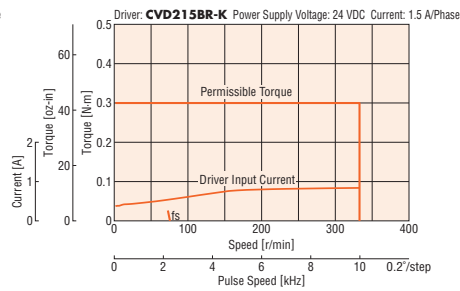

PKP223D15A-SG10/PKP223D15B-SG10

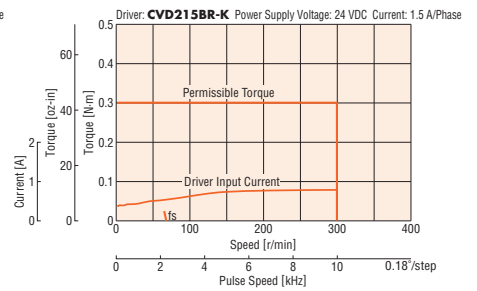

PKP223D15A-SG18/PKP223D15B-SG18

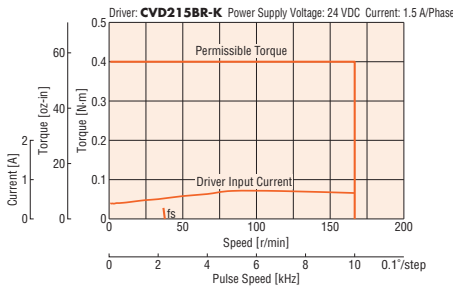

PKP223D15A-SG36/PKP223D15B-SG36

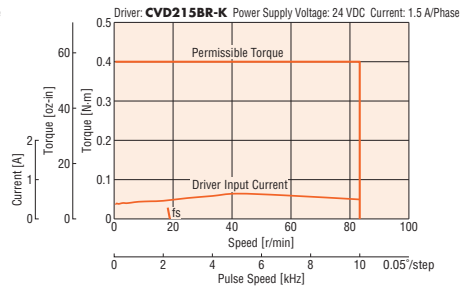

Note

- Data for the speed – torque characteristics is based on Oriental Motor's internal measurement conditions. If the conditions are changed, the characteristics may also change as a result.
- Depending on the driving conditions, a considerable amount of heat may be generated by the motor. Be sure to keep the motor case temperature at 100°C (212°F) max.
- Set the current of the driver so that it does not exceed the rated current of the motor.

Dimensions Unit: mm (in.)

Motor

2D & 3D CAD

Product Name	Gear Ratio	Mass kg (lb.)	2D CAD
PKP223D15A-SG□	7.2, 9	0.16	B985
PKP223D15B-SG□	10, 18, 36	(0.35)	

● The box □ in the product name indicates a number representing the gear ratio.

● Applicable Connector

Connector Housing: 51065-0600 (Molex)

Contact: 50212-8100 (Molex)

Crimp Tool: 57176-5000 (Molex)

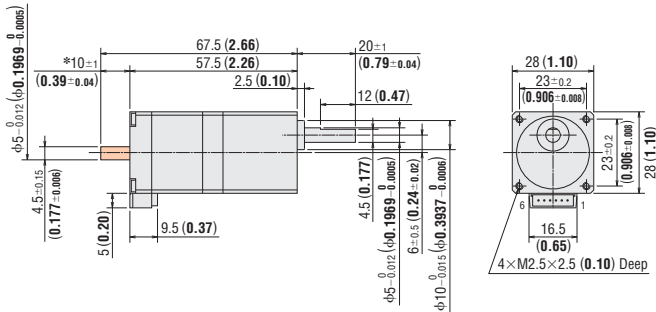

*The length of the shaft flat on the double shaft model is $10_{\pm 0.25}$ (0.394 ± 0.010).

● These dimensions are for double shaft motors.

For single shaft motors, ignore the shaded areas.

● Connection Cable (Sold separately)

◇ Motor Connection Cable

Product Name	Length L [m (ft.)]
LC2B06A	0.6 (2)
LC2B10A	1 (3.3)

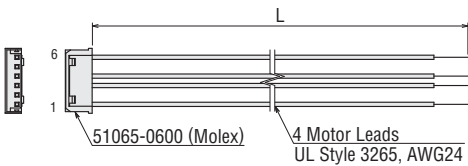

Inner Wiring Diagram of Motor

Wiring Diagram No.: Model B③

● Refer to page 67 for inner wiring diagram of motor.

SH Geared Type

Frame Size 42 mm (1.65 in.) (Bipolar 4 Lead Wires)

20 mm
(0.79 in.)

28 mm
(1.10 in.)

35 mm
(1.38 in.)

42 mm
(1.65 in.)

50 mm
(1.97 in.)
51 mm
(2.01 in.)

56.4 mm
(2.22 in.)

60 mm
(2.36 in.)
61 mm
(2.40 in.)

85 mm
(3.35 in.)

Specifications

Product Name	Maximum Holding Torque N·m (lb-in)	Rotor Inertia J: kg·m ² (oz-in ²)	Rated Current A/Phase	Voltage VDC	Winding Resistance Ω/Phase	Inductance mH/Phase	Basic Step Angle	Gear Ratio	Permissible Torque N·m (lb-in)	Speed Range r/min	Backlash arcmin	Recommended Driver Product Name*
PKP243D15□2-SG3.6	0.2 (1.77)	36×10 ⁻⁷ (0.197)	1.5	0.83	0.55	0.77	0.5°	3.6	0.2 (1.77)	0 - 833	90 (1.5°)	CVD223FBR-K
PKP243D23□2-SG3.6	0.4 (3.5)		2.3	0.87	0.38	0.41						
PKP243D15□2-SG7.2	0.5 (4.4)		1.5	0.83	0.55	0.77	0.25°	7.2	0.4 (3.5)	0 - 416		
PKP243D23□2-SG7.2	0.8 (7)		2.3	0.87	0.38	0.41						
PKP243D15□2-SG9	0.56 (4.9)		1.5	0.83	0.55	0.77	0.2°	9	0.5 (4.4)	0 - 333		
PKP243D23□2-SG9	0.8 (7)		2.3	0.87	0.38	0.41						
PKP243D15□2-SG10	0.8 (7)		1.5	0.83	0.55	0.77	0.18°	10	0.56 (4.9)	0 - 300		
PKP243D23□2-SG10	0.8 (7)		2.3	0.87	0.38	0.41						
PKP243D15□2-SG18	0.8 (7)		1.5	0.83	0.55	0.77	0.1°	18	0.8 (7)	0 - 166		
PKP243D23□2-SG18	0.8 (7)		2.3	0.87	0.38	0.41						
PKP243D15□2-SG36	0.8 (7)		1.5	0.83	0.55	0.77	0.05°	36	0.8 (7)	0 - 83		
PKP243D23□2-SG36	0.8 (7)		2.3	0.87	0.38	0.41						

● The box □ in the product name indicates the shaft **A** (single shaft) or **B** (double shaft).

*See page 94 for details on the recommended drivers.

Speed – Torque Characteristics (Reference Values) *fs*: Max. Starting Frequency

PKP243D15A2-SG3.6/ PKP243D15B2-SG3.6

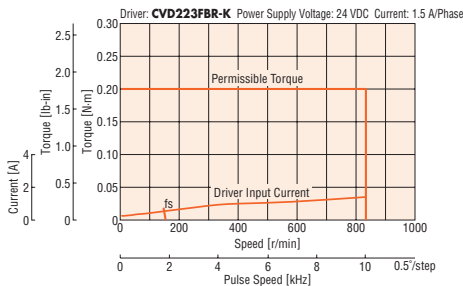

PKP243D15A2-SG7.2/ PKP243D15B2-SG7.2

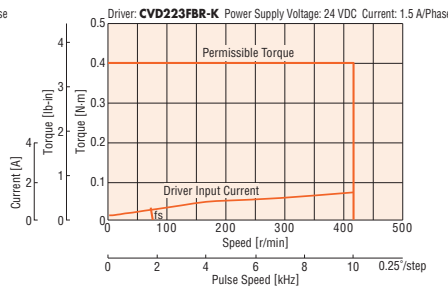

PKP243D15A2-SG9/ PKP243D15B2-SG9

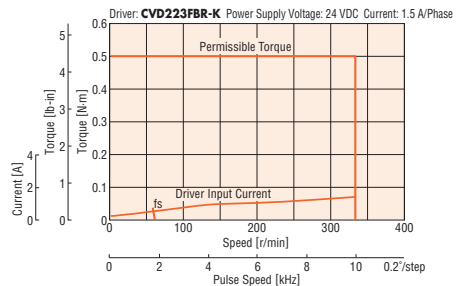

PKP243D15A2-SG10/ PKP243D15B2-SG10

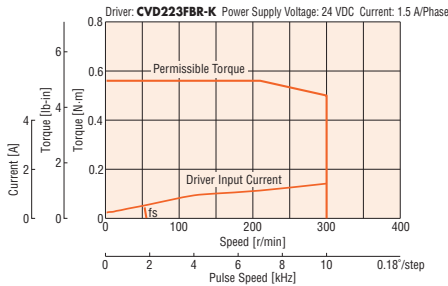

PKP243D15A2-SG18/ PKP243D15B2-SG18

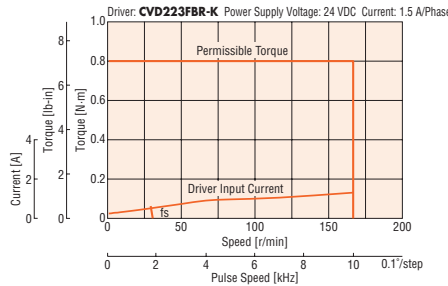

PKP243D15A2-SG36/ PKP243D15B2-SG36

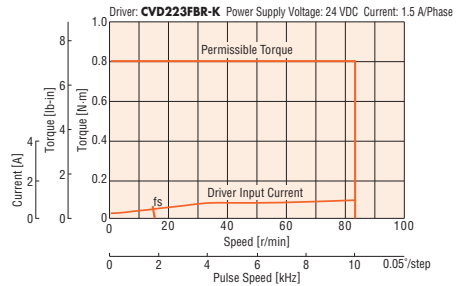

Note

- Data for the speed – torque characteristics is based on Oriental Motor's internal measurement conditions. If the conditions are changed, the characteristics may also change as a result.
- Depending on the driving conditions, a considerable amount of heat may be generated by the motor. Be sure to keep the motor case temperature at 100°C (212°F) max.
- Set the current of the driver so that it does not exceed the rated current of the motor.

Speed – Torque Characteristics (Reference Values) f_s : Max. Starting Frequency

PKP243D23A2-SG3.6/PKP243D23B2-SG3.6

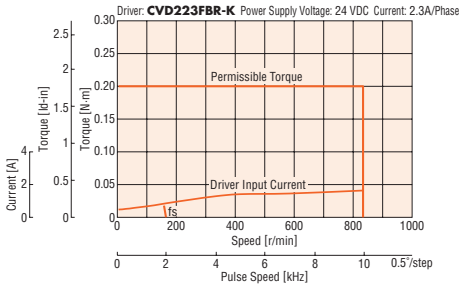

PKP243D23A2-SG7.2/PKP243D23B2-SG7.2

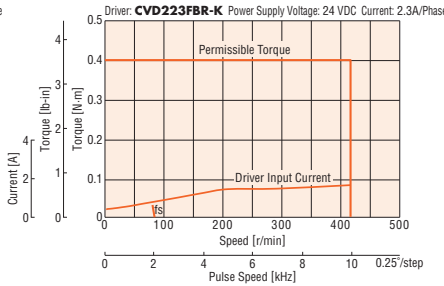

PKP243D23A2-SG9/PKP243D23B2-SG9

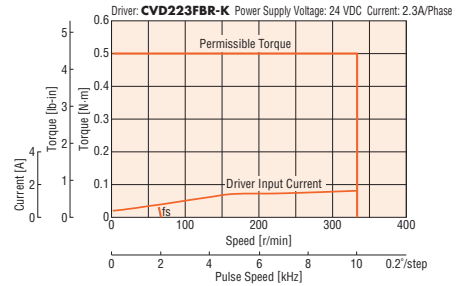

PKP243D23A2-SG10/PKP243D23B2-SG10

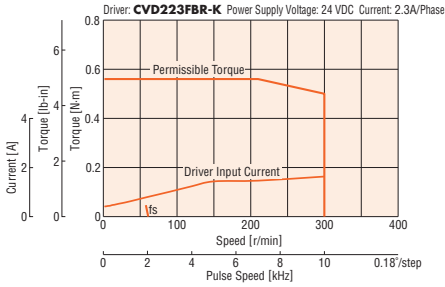

PKP243D23A2-SG18/PKP243D23B2-SG18

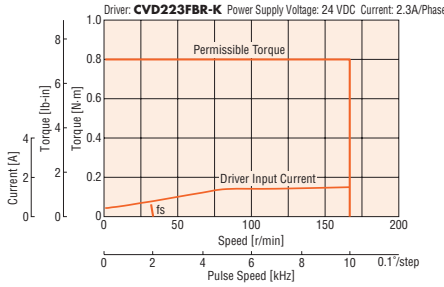

PKP243D23A2-SG36/PKP243D23B2-SG36

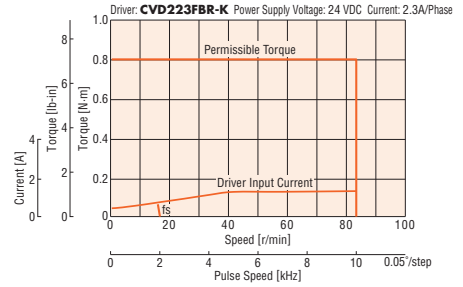

Note

- Data for the speed – torque characteristics is based on Oriental Motor's internal measurement conditions. If the conditions are changed, the characteristics may also change as a result.
- Depending on the driving conditions, a considerable amount of heat may be generated by the motor. Be sure to keep the motor case temperature at 100°C (212°F) max.
- Set the current of the driver so that it does not exceed the rated current of the motor.

Dimensions Unit: mm (in.)

Motor

2D & 3D CAD

Product Name	Gear Ratio	Mass kg (lb.)	2D CAD
PKP243D15A2-SG□	3.6, 7.2, 9, 10, 18, 36	0.33 (0.73)	B1340
PKP243D15B2-SG□			
PKP243D23A2-SG□			
PKP243D23B2-SG□			

● The box □ in the product name indicates a number representing the gear ratio.

Applicable Connector

Connector Housing: MDF97-5S-3.5C (HIROSE ELECTRIC CO., LTD.)
 Contact: MDF97-22SC (HIROSE ELECTRIC CO., LTD.)
 Crimp Tool: HT801/MDF97-22S (HIROSE ELECTRIC CO., LTD.)

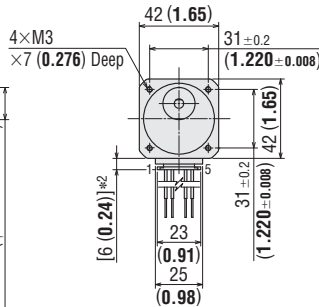
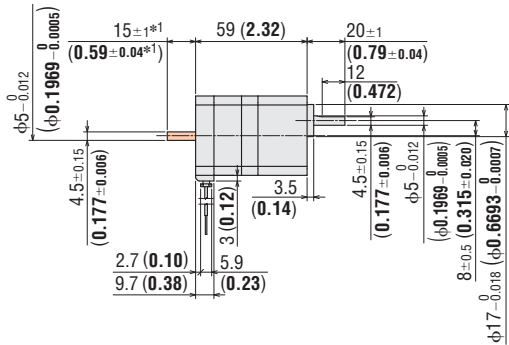

- *1 The length of the shaft flat on the double shaft model is 15±0.25 (0.591±0.010).
- *2 With connection cable
- These dimensions are for double shaft motors.
 For single shaft motors, ignore the shaded areas.

Connection Cable (Sold separately)

Motor Connection Cable

Product Name	Length L [m (ft.)]
LC2B06E	0.6 (2)
LC2B10E	1 (3.3)

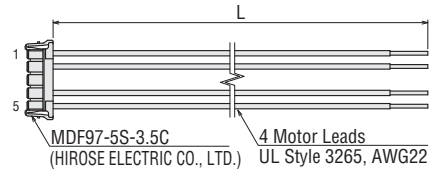

Inner Wiring Diagram of Motor

Wiring Diagram No.: Model A①

- Refer to page 67 for inner wiring diagram of motor.

2-Phase Motors PKP

Features Product Line

Product Number Product Line

Standard Type

High-Resolution Type

Flat Type

SH Geared Type

CS Geared Type

General Specifications/ Inner Wiring Diagram of Motor

5-Phase Motors PKP

Features Product Line

Product Number Product Line

Standard Type

High-Resolution Type

TS Geared Type

General Specifications/ Inner Wiring Diagram of Motor

Driver for 2-Phase/ 5-Phase Motors

Accessories

SH Geared Type with Encoder Frame Size 42 mm (1.65 in.) (Bipolar 4 Lead Wires)

20 mm
(0.79 in.)

28 mm
(1.10 in.)

35 mm
(1.38 in.)

42 mm
(1.65 in.)

50 mm
(1.97 in.)
51 mm
(2.01 in.)

56.4 mm
(2.22 in.)

60 mm
(2.36 in.)
61 mm
(2.40 in.)

85 mm
(3.35 in.)

Specifications

Product Name	Maximum Holding Torque N·m (lb·in)	Rotor Inertia J: kg·m ² (oz·in ²)	Rated Current	Voltage	Winding Resistance	Inductance	Basic Step Angle	Gear Ratio	Permissible Torque N·m (lb·in)	Speed Range r/min	Backlash arcmin	Recommended Driver Product Name*
			A/Phase	VDC	Ω/Phase	mH/Phase						
PKP243D15A2-SG3.6-R2FL	0.2	36 × 10 ⁻⁷ (0.197)	1.5	0.83	0.55	0.77	0.5°	3.6	0.2 (1.77)	0 - 833	90 (1.5°)	CVD223FBR-K
PKP243D23A2-SG3.6-R2FL	(1.77)		2.3	0.87	0.38	0.41						
PKP243D15A2-SG7.2-R2FL	0.4		1.5	0.83	0.55	0.77	0.25°	7.2	0.4 (3.5)	0 - 416		
PKP243D23A2-SG7.2-R2FL	(3.5)		2.3	0.87	0.38	0.41						
PKP243D15A2-SG9-R2FL	0.5		1.5	0.83	0.55	0.77	0.2°	9	0.5 (4.4)	0 - 333		
PKP243D23A2-SG9-R2FL	(4.4)		2.3	0.87	0.38	0.41						
PKP243D15A2-SG10-R2FL	0.56		1.5	0.83	0.55	0.77	0.18°	10	0.56 (4.9)	0 - 300		
PKP243D23A2-SG10-R2FL	(4.9)		2.3	0.87	0.38	0.41						
PKP243D15A2-SG18-R2FL	0.8		1.5	0.83	0.55	0.77	0.1°	18	0.8 (7)	0 - 166		
PKP243D23A2-SG18-R2FL	(7)		2.3	0.87	0.38	0.41						
PKP243D15A2-SG36-R2FL	0.8		1.5	0.83	0.55	0.77	0.05°	36	0.8 (7)	0 - 83		
PKP243D23A2-SG36-R2FL	(7)		2.3	0.87	0.38	0.41						

● See page 64 for encoder specifications.

*See page 94 for details on the recommended drivers.

Speed – Torque Characteristics (Reference Values) fs: Max. Starting Frequency

PKP243D15A2-SG3.6-R2FL

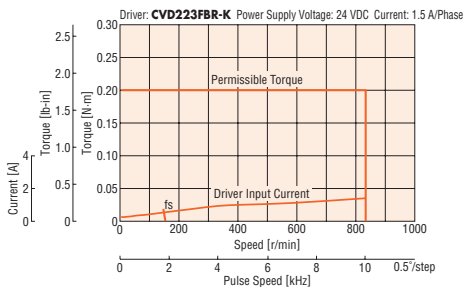

PKP243D15A2-SG7.2-R2FL

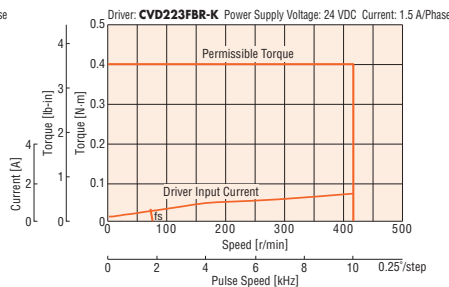

PKP243D15A2-SG9-R2FL

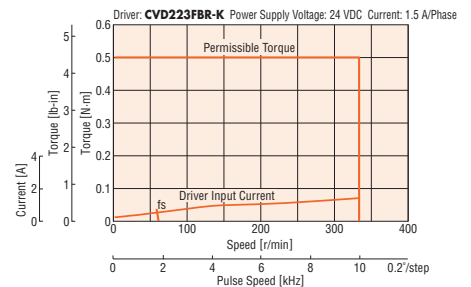

PKP243D15A2-SG10-R2FL

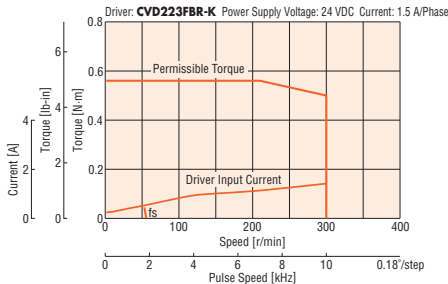

PKP243D15A2-SG18-R2FL

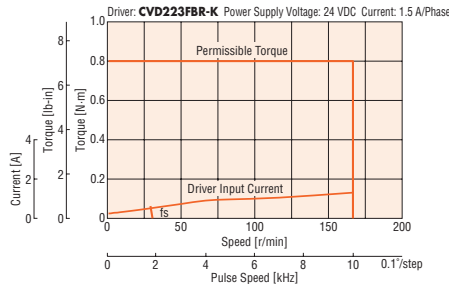

PKP243D15A2-SG36-R2FL

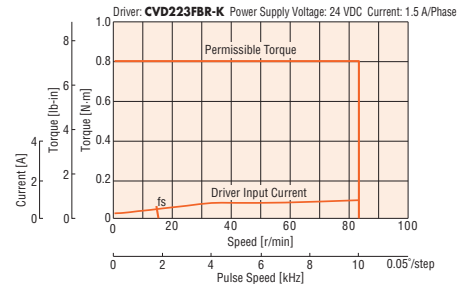

Note

- Data for the speed – torque characteristics is based on Oriental Motor's internal measurement conditions. If the conditions are changed, the characteristics may also change as a result.
- Depending on the driving conditions, a considerable amount of heat may be generated by the motor. Be sure to keep the motor case temperature at 85°C (185°F) max.
- Set the current of the driver so that it does not exceed the rated current of the motor.

Speed – Torque Characteristics (Reference Values) f_s : Max. Starting Frequency

PKP243D23A2-SG3.6-R2FL

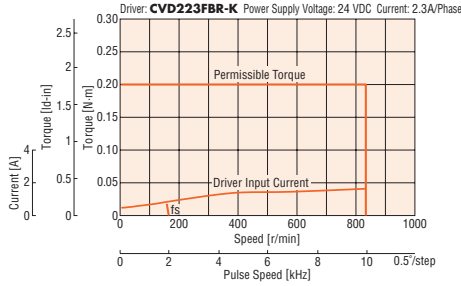

PKP243D23A2-SG7.2-R2FL

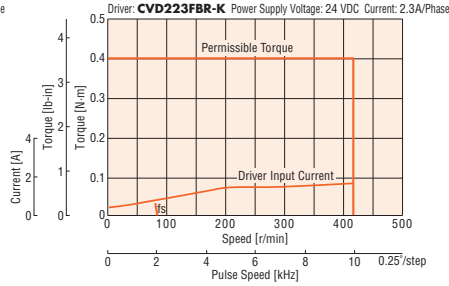

PKP243D23A2-SG9-R2FL

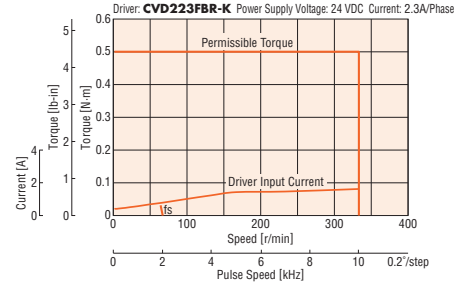

PKP243D23A2-SG10-R2FL

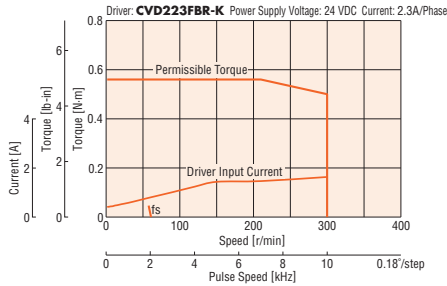

PKP243D23A2-SG18-R2FL

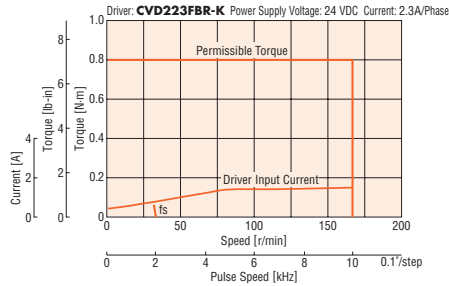

PKP243D23A2-SG36-R2FL

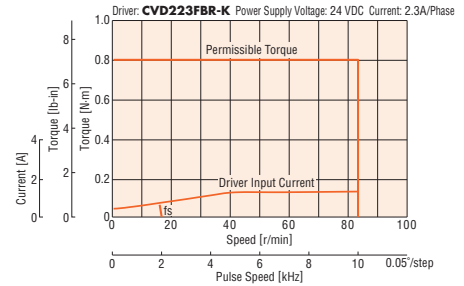

Note

- Data for the speed – torque characteristics is based on Oriental Motor's internal measurement conditions. If the conditions are changed, the characteristics may also change as a result.
- Depending on the driving conditions, a considerable amount of heat may be generated by the motor. Be sure to keep the motor case temperature at 85°C (185°F) max.
- Set the current of the driver so that it does not exceed the rated current of the motor.

Dimensions Unit: mm (in.)

Motor

2D & 3D CAD

Product Name	Gear Ratio	Mass kg (lb.)	2D CAD
PKP243D15A2-SG□-R2FL	3.6, 7.2, 9	0.33 (0.73)	B1508
PKP243D23A2-SG□-R2FL	10, 18, 36		

- The box □ in the product name indicates a number representing the gear ratio.

Applicable Connector

	Motor (HIROSE ELECTRIC CO.,LTD.)	Encoder (Molex)
Connector Housing	MDF97-5S-3.5C	51021-0800
Contact	MDF97-22SC	50079-8100
Crimping Tool	HT801/MDF97-22S	57177-5000

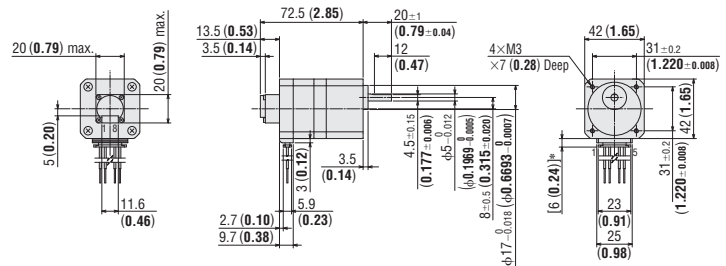

*With connection cable

Connection Cable (Sold separately)

Motor Connection Cable

Product Name	Length L [m (ft.)]
LC2B06E	0.6 (2)
LC2B10E	1 (3.3)

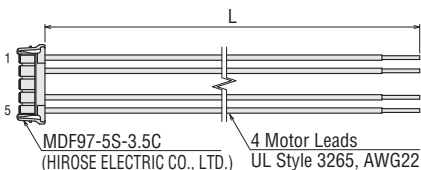

Encoder Connection Cable

Product Name	Length L [m (ft.)]
LCE08A-006	0.6 (2)

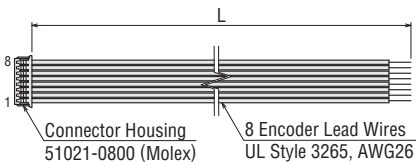

Inner Wiring Diagram of Motor

Wiring Diagram No.: Model A①

- Refer to page 67 for inner wiring diagram of motor.

2-Phase Motors PKP

Features Product Line

Product Number Product Line

Standard Type

High-Resolution Type

Flat Type

SH Geared Type

CS Geared Type

General Specifications/ Inner Wiring Diagram of Motor

5-Phase Motors PKP

Features Product Line

Product Number Product Line

Standard Type

High-Resolution Type

TS Geared Type

General Specifications/ Inner Wiring Diagram of Motor

Driver for 2-Phase/ 5-Phase Motors

Accessories

SH Geared Type

Frame Size 60 mm (2.36 in.) (Bipolar 4 Lead Wires)

20 mm
(0.79 in.)

28 mm
(1.10 in.)

35 mm
(1.38 in.)

42 mm
(1.65 in.)

50 mm
(1.97 in.)
51 mm
(2.01 in.)

56.4 mm
(2.22 in.)

60 mm
(2.36 in.)
61 mm
(2.40 in.)

85 mm
(3.35 in.)

Specifications

Product Name	Maximum Holding Torque N-m (lb-in)	Rotor Inertia J: kg·m ² (oz-in ²)	Rated Current A/Phase	Voltage VDC	Winding Resistance Ω/Phase	Inductance mH/Phase	Basic Step Angle	Gear Ratio	Permissible Torque N-m (lb-in)	Speed Range r/min	Backlash arcmin	Recommended Driver Product Name*	
PKP264D14□2-SG3.6	1 (8.8)	140×10 ⁻⁷ (0.77)	1.4	2	1.4	3.1	0.5°	3.6	1 (8.8)	0 - 833	70 (1.17°)	CVD228BR-K	
PKP264D28□2-SG3.6			2.8	0.92	0.33	0.81							
PKP264D14□2-SG7.2	2 (17.7)		1.4	1.4	2	1.4	3.1	0.25°	7.2	2 (17.7)			0 - 416
PKP264D28□2-SG7.2				2.8	0.92	0.33	0.81						
PKP264D14□2-SG9	2.5 (22)		1.4	1.4	2	1.4	3.1	0.2°	9	2.5 (22)			0 - 333
PKP264D28□2-SG9				2.8	0.92	0.33	0.81						
PKP264D14□2-SG10	2.7 (23)		1.4	1.4	2	1.4	3.1	0.18°	10	2.7 (23)			0 - 300
PKP264D28□2-SG10				2.8	0.92	0.33	0.81						
PKP264D14□2-SG18	3 (26)		1.4	1.4	2	1.4	3.1	0.1°	18	3 (26)			0 - 166
PKP264D28□2-SG18				2.8	0.92	0.33	0.81						
PKP264D14□2-SG36	4 (35)		1.4	1.4	2	1.4	3.1	0.05°	36	4 (35)			0 - 83
PKP264D28□2-SG36				2.8	0.92	0.33	0.81						

● The box □ in the product name indicates the shaft **A** (single shaft) or **B** (double shaft).

*See page 94 for details on the recommended drivers.

Speed – Torque Characteristics (Reference Values) *f_s*: Max. Starting Frequency

PKP264D14A2-SG3.6/PKP264D14B2-SG3.6

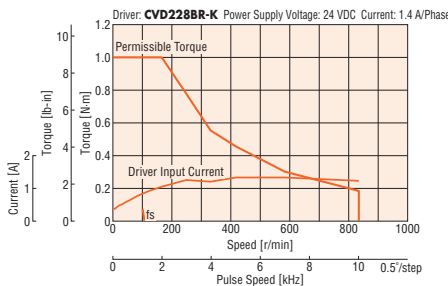

PKP264D14A2-SG7.2/PKP264D14B2-SG7.2

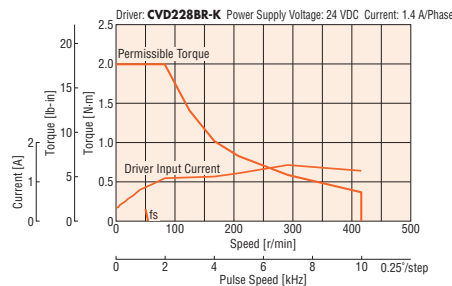

PKP264D14A2-SG9/PKP264D14B2-SG9

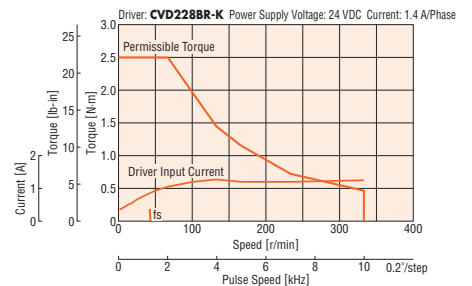

PKP264D14A2-SG10/PKP264D14B2-SG10

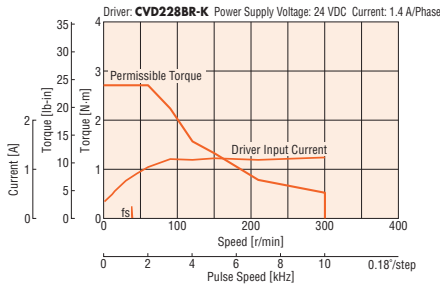

PKP264D14A2-SG18/PKP264D14B2-SG18

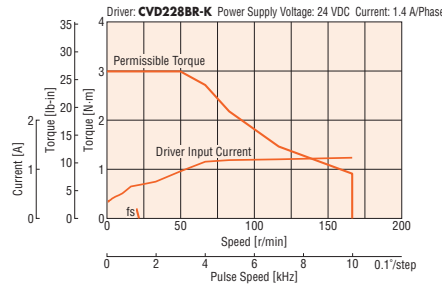

PKP264D14A2-SG36/PKP264D14B2-SG36

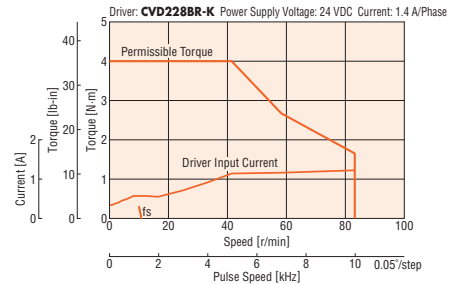

Note

- Data for the speed – torque characteristics is based on Oriental Motor's internal measurement conditions. If the conditions are changed, the characteristics may also change as a result.
- Depending on the driving conditions, a considerable amount of heat may be generated by the motor. Be sure to keep the motor case temperature at 100°C (212°F) max.
- Set the current of the driver so that it does not exceed the rated current of the motor.

Speed – Torque Characteristics (Reference Values)

PKP264D28A2-SG3.6/ PKP264D28B2-SG3.6

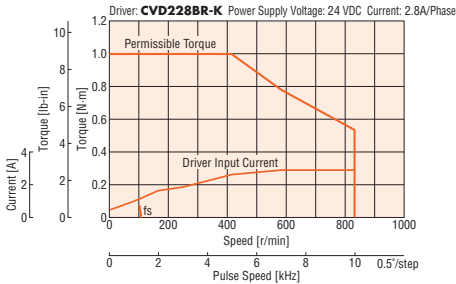

PKP264D28A2-SG7.2/ PKP264D28B2-SG7.2

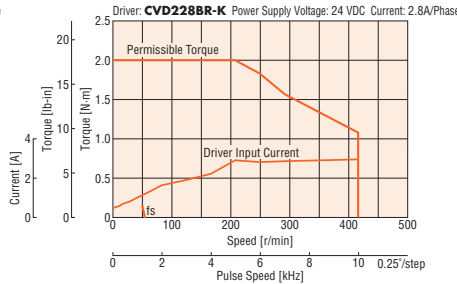

PKP264D28A2-SG9/ PKP264D28B2-SG9

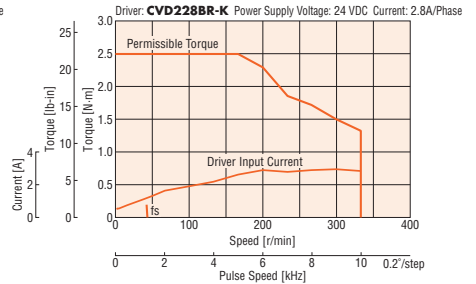

PKP264D28A2-SG10/ PKP264D28B2-SG10

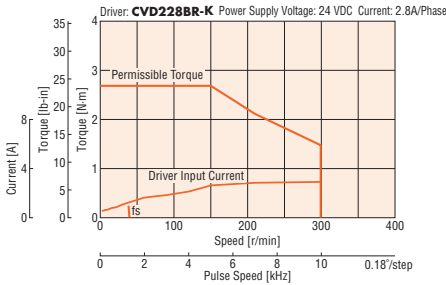

PKP264D28A2-SG18/ PKP264D28B2-SG18

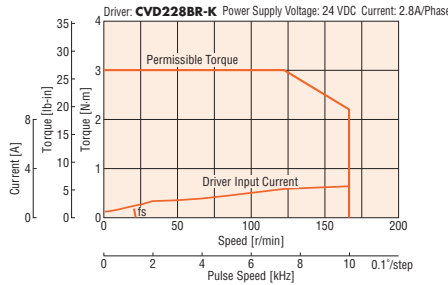

PKP264D28A2-SG36/ PKP264D28B2-SG36

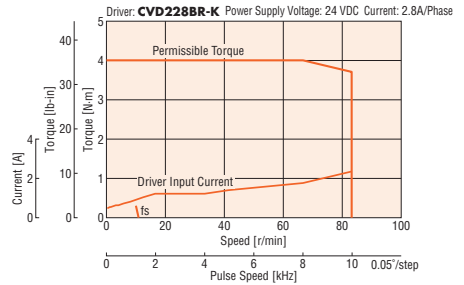

Note

- Data for the speed – torque characteristics is based on Oriental Motor's internal measurement conditions. If the conditions are changed, the characteristics will also change as a result.
- Depending on the driving conditions, a considerable amount of heat may be generated by the motor. Be sure to keep the motor case temperature at 100°C (212°F) max.
- Set the current of the driver so that it does not exceed the rated current of the motor.

Dimensions Unit: mm (in.)

● Motor

2D & 3D CAD

Product Name	Gear Ratio	Mass kg (lb.)	2D CAD
PKP264D14A2-SG□	3.6, 7.2, 9, 10, 18, 36	0.76 (1.67)	B1342
PKP264D14B2-SG□			
PKP264D28A2-SG□			
PKP264D28B2-SG□			

● The box □ in the product name indicates a number representing the gear ratio.

● Applicable Connector

Connector Housing: MDF97-5S-3.5C (HIROSE ELECTRIC CO., LTD.)
 Contact: MDF97-22SC (HIROSE ELECTRIC CO., LTD.)
 Crimp Tool: HT801/MDF97-22S (HIROSE ELECTRIC CO., LTD.)

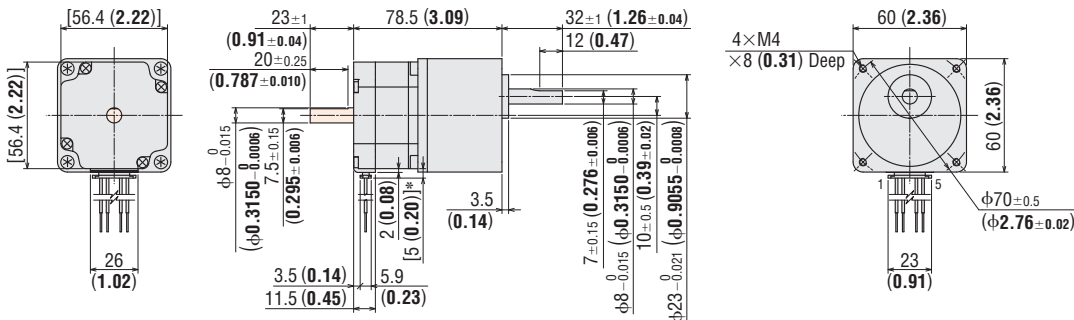

*With connection cable

● These dimensions are for double shaft motors.

For single shaft motors, ignore the shaded areas.

● Connection Cables (Sold separately)

◇ Motor Connection Cable

Product Name	Length L [m (ft.)]
LC2B06E	0.6 (2)
LC2B10E	1 (3.3)

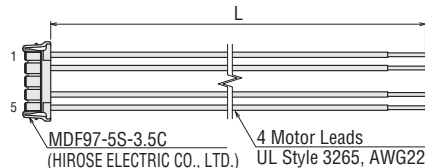

Inner Wiring Diagram of Motor

Wiring Diagram No.: Model A①

● Refer to page 67 for inner wiring diagram of motor.

2-Phase Motors PKP

Features Product Line

Product Number Product Line

Standard Type

High-Resolution Type

Flat Type

SH Geared Type

CS Geared Type

General Specifications/ Inner Wiring Diagram of Motor

5-Phase Motors PKP

Features Product Line

Product Number Product Line

Standard Type

High-Resolution Type

TS Geared Type

General Specifications/ Inner Wiring Diagram of Motor

Driver for 2-Phase/ 5-Phase Motors

Accessories

SH Geared Type with Encoder Frame Size 60 mm (2.36 in.) (Bipolar 4 Lead Wires)

- 20 mm (0.79 in.)
- 28 mm (1.10 in.)
- 35 mm (1.38 in.)
- 42 mm (1.65 in.)
- 50 mm (1.97 in.)
- 51 mm (2.01 in.)
- 56.4 mm (2.22 in.)
- 60 mm (2.36 in.)
- 61 mm (2.40 in.)
- 85 mm (3.35 in.)

Specifications

Product Name	Maximum Holding Torque N·m (lb-in)	Rotor Inertia J: kg·m ² (oz-in ²)	Rated Current A/Phase	Voltage VDC	Winding Resistance Ω/Phase	Inductance mH/Phase	Basic Step Angle	Gear Ratio	Permissible Torque N·m (lb-in)	Speed Range r/min	Backlash arcmin	Recommended Driver Product Name*
PKP264D28A2-SG3.6-R2FL	1 (8.8)	140×10 ⁻⁷ (0.77)	2.8	0.92	0.33	0.81	0.5°	3.6	1 (8.8)	0 - 833	70 (1.17°)	CVD228BR-K
PKP264D28A2-SG7.2-R2FL	2 (17.7)						0.25°	7.2	2 (17.7)	0 - 416		
PKP264D28A2-SG9-R2FL	2.5 (22)						0.2°	9	2.5 (22)	0 - 333		
PKP264D28A2-SG10-R2FL	2.7 (23)						0.18°	10	2.7 (23)	0 - 300		
PKP264D28A2-SG18-R2FL	3 (26)						0.1°	18	3 (26)	0 - 166		
PKP264D28A2-SG36-R2FL	4 (35)						0.05°	36	4 (35)	0 - 83		

● See page 64 for encoder specifications.

*See page 94 for details on the recommended drivers.

Speed – Torque Characteristics (Reference Values) fs: Max. Starting Frequency

PKP264D28A2-SG3.6-R2FL

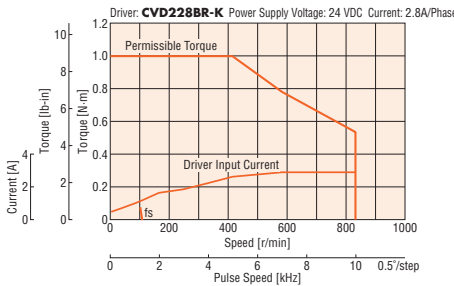

PKP264D28A2-SG7.2-R2FL

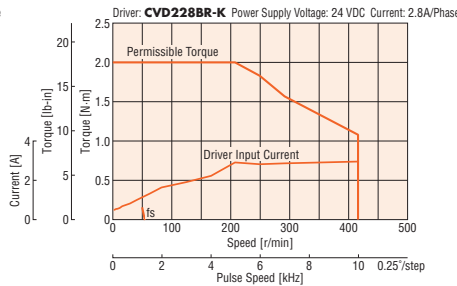

PKP264D28A2-SG9-R2FL

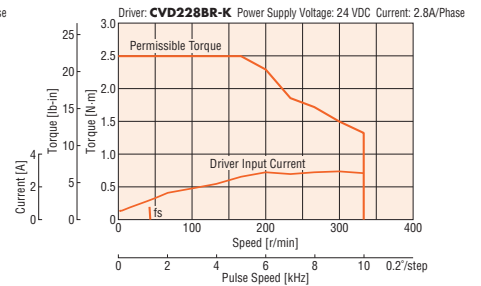

PKP264D28A2-SG10-R2FL

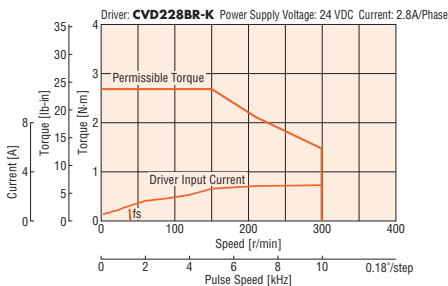

PKP264D28A2-SG18-R2FL

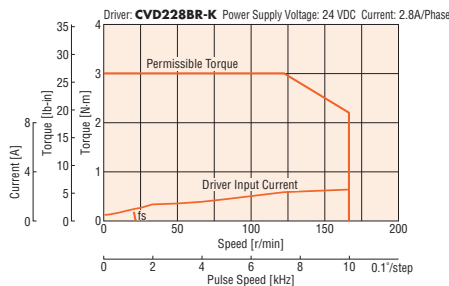

PKP264D28A2-SG36-R2FL

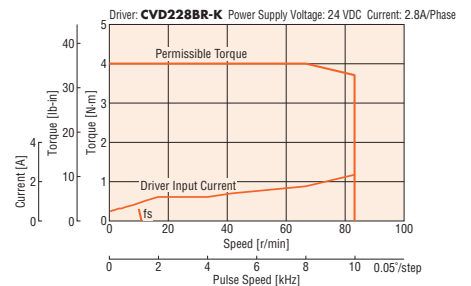

Note

- Data for the speed – torque characteristics is based on Oriental Motor's internal measurement conditions. If the conditions are changed, the characteristics may also change as a result.
- Depending on the driving conditions, a considerable amount of heat may be generated by the motor. Be sure to keep the motor case temperature at 85°C (185°F) max.
- Set the current of the driver so that it does not exceed the rated current of the motor.

Dimensions Unit: mm (in.)

● Motor

2D & 3D CAD

Product Name	Gear Ratio	Mass kg (lb.)	2D CAD
PKP264D28A2-SG□-R2FL	3.6, 7.2, 9, 10, 18, 36	0.77 (1.69)	B1509

● The box □ in the product name indicates a number representing the gear ratio.

● Applicable Connector

	Motor (HIROSE ELECTRIC CO., LTD.)	Encoder (Molex)
Connector Housing	MDF97-5S-3.5C	51021-0800
Contact	MDF97-22SC	50079-8100
Crimping Tool	HT801/MDF97-22S	57177-5000

● Connection Cables (Sold separately)

◇ Motor Connection Cable

Product Name	Length L [m (ft.)]
LC2B06E	0.6 (2)
LC2B10E	1 (3.3)

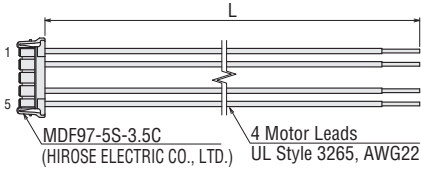

◇ Encoder Connection Cable

Product Name	Length L [m (ft.)]
LCE08A-006	0.6 (2)

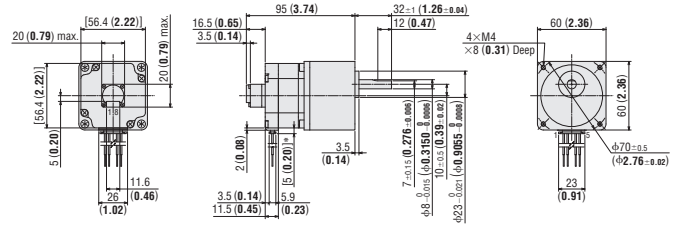
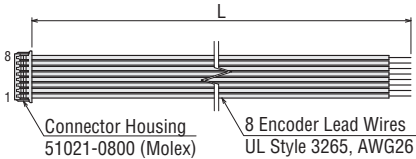

*With connection cable

Inner Wiring Diagram of Motor

Wiring Diagram No.: Model A①

● Refer to page 67 for inner wiring diagram of motor.

2-Phase
Motors
PKP

Features
Product
Line

Product
Number
Product Line

Standard
Type

High-
Resolution
Type

Flat Type

SH
Geared
Type

CS
Geared
Type

General
Specifications/
Inner Wiring
Diagram of Motor

5-Phase
Motors
PKP

Features
Product
Line

Product
Number
Product Line

Standard
Type

High-
Resolution
Type

TS
Geared
Type

General
Specifications/
Inner Wiring
Diagram of Motor

Driver for
2-Phase/
5-Phase Motors

Accessories

CS Geared Type

Frame Size 42 mm (Bipolar 4 lead wires)

20 mm
(0.79 in.)

28 mm
(1.10 in.)

35 mm
(1.38 in.)

42 mm
(1.65 in.)

50 mm
(1.97 in.)
51 mm
(2.01 in.)

56.4 mm
(2.22 in.)

60 mm
(2.36 in.)
61 mm
(2.40 in.)

85 mm
(3.35 in.)

Specifications

Product Name	Maximum Holding Torque N-m (lbs)	Rotor Inertia J: kg·m ² (oz·in ²)	Rated Current A/Phase	Voltage VDC	Winding Resistance Ω/Phase	Inductance mH/Phase	Basic Step Angle	Gear Ratio	Permissible Torque N-m (lbs-in)	Speed Range r/min	Recommended Driver Product Name
PKP243D15□2-CS5 PKP243D23□2-CS5	0.5 (4.4)	37×10 ⁻⁷ (0.202)	1.5	0.83	0.55	0.77	0.36°	5	0.5 (4.4)	0 - 600	CVD223FBR-K
PKP243D15□2-CS10 PKP243D23□2-CS10			2.3	0.87	0.38	0.41					
PKP243D15□2-CS15 PKP243D23□2-CS15	1 (8.8)		1.5	0.83	0.55	0.77	0.18°	10	1 (8.8)	0 - 300	
			2.3	0.87	0.38	0.41					
PKP243D15□2-CS20 PKP243D23□2-CS20	1.5 (13.2)		1.5	0.83	0.55	0.77	0.12°	15	1.5 (13.2)	0 - 200	
			2.3	0.87	0.38	0.41					
PKP243D15□2-CS20 PKP243D23□2-CS20	2 (17.7)	1.5	0.83	0.55	0.77	0.09°	20	2 (17.7)	0 - 150		
		2.3	0.87	0.38	0.41						

● The box □ in the product name indicates the shaft **A** (single shaft) or **B** (double shaft).

● The backlash is 1.5° for gear ratio 5, and 1° otherwise. (Reference value)

Speed – Torque Characteristics (Reference Values) fs: Max. Starting Frequency

PKP243D15A2-CS5/PKP243D15B2-CS5

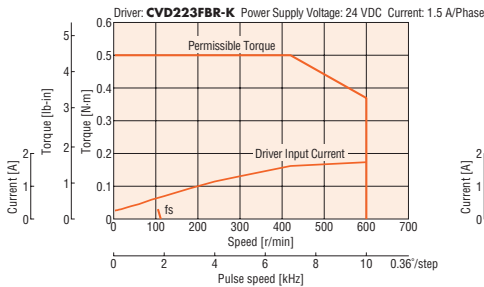

PKP243D15A2-CS10/PKP243D15B2-CS10

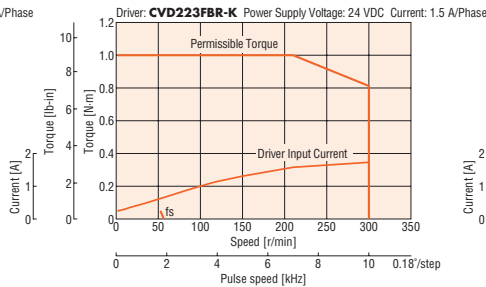

PKP243D15A2-CS15/PKP243D15B2-CS15

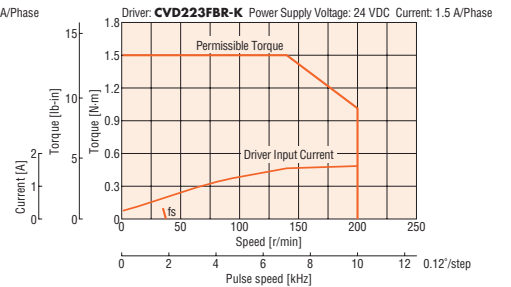

PKP243D15A2-CS20/PKP243D15B2-CS20

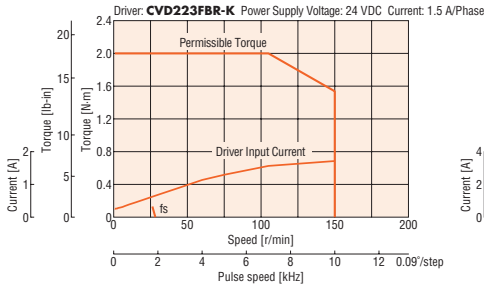

PKP243D23A2-CS5/PKP243D23B2-CS5

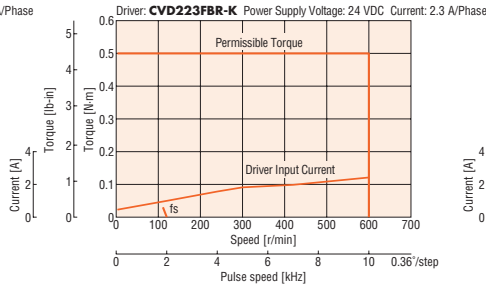

PKP243D23A2-CS10/PKP243D23B2-CS10

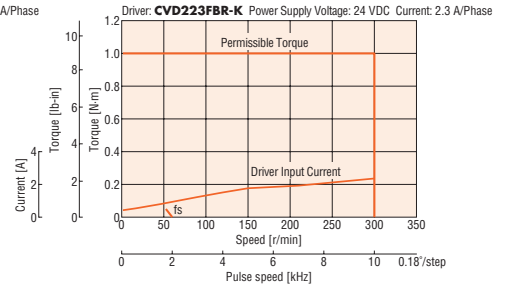

PKP243D23A2-CS15/PKP243D23B2-CS15

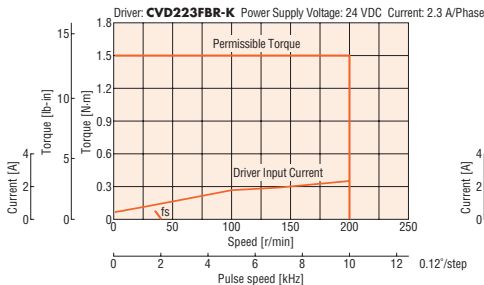

PKP243D23A2-CS20/PKP243D23B2-CS20

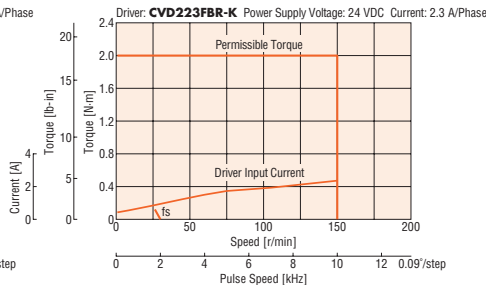

Note

- Data for the speed – torque characteristics is based on Oriental Motor's internal measurement conditions. If the conditions are changed, the characteristics may also change as a result.
- Depending on the driving conditions, a considerable amount of heat may be generated by the motor. Be sure to keep the motor case temperature at 100°C (212°F) max.
- Set the current of the driver so that it does not exceed the rated current of the motor.

Dimensions Unit: mm (in.)

Motor

2D & 3D CAD

Product Name	Gear Ratio	Mass kg (lbs.)	2D CAD
PKP243D15A2-CS□	5, 10, 15, 20	0.4 (0.09)	B1510A
PKP243D15B2-CS□			B1510B
PKP243D23A2-CS□			B1510A
PKP243D23B2-CS□			B1510B

- The box □ in the product name indicates a number representing the gear ratio.
- Applicable Connector
Connector Housing: MDF97-5S-3.5C (HIROSE ELECTRIC CO., LTD.)
Contact: MDF97-22SC (HIROSE ELECTRIC CO., LTD.)
Crimp Tool: HT801/MDF97-22S (HIROSE ELECTRIC CO., LTD.)

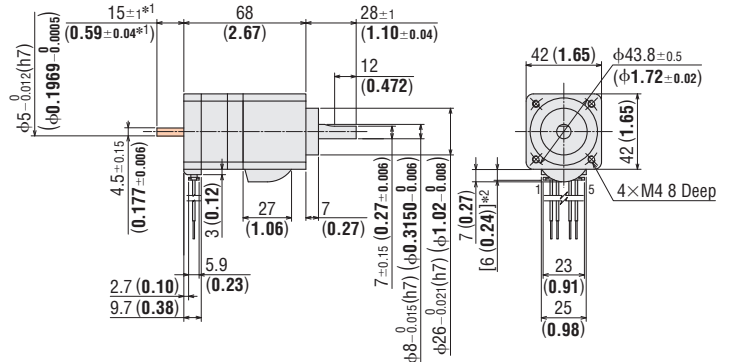

*1 The length of the shaft flat on the double shaft model is 15 ± 0.25 .

*2 With connection cable

● These dimensions are for double shaft motors.

For single shaft motors, ignore the shaded areas.

Connection Cable (Sold separately)

Motor Connection Cable

Product Name	Length L [m (ft.)]
LC2B06E	0.6 (2)
LC2B10E	1 (3.3)

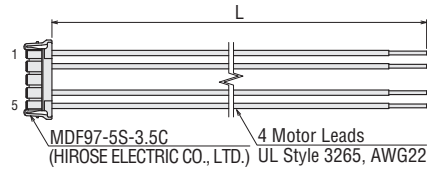

Inner Wiring Diagram of Motor

Wiring Diagram No.: Model A①

- Refer to page 67 for inner wiring diagram of motor.

2-Phase
Motors
PKP

Features
Product
Line

Product
Number
Product Line

Standard
Type

High-
Resolution
Type

Flat Type

SH
Geared
Type

CS
Geared
Type

General
Specifications/
Inner Wiring
Diagram of Motor

5-Phase
Motors
PKP

Features
Product
Line

Product
Number
Product Line

Standard
Type

High-
Resolution
Type

TS
Geared
Type

General
Specifications/
Inner Wiring
Diagram of Motor

Driver for
2-Phase/
5-Phase Motors

Accessories

20 mm
(0.79 in.)

28 mm
(1.10 in.)

35 mm
(1.38 in.)

42 mm
(1.65 in.)

50 mm
(1.97 in.)
51 mm
(2.01 in.)

56.4 mm
(2.22 in.)

60 mm
(2.36 in.)
61 mm
(2.40 in.)

85 mm
(3.35 in.)

General Specifications

Specifications		Motor
Thermal Class		130 (B)
Insulation Resistance		The measured value is 100 MΩ min. when a 500 VDC megger is applied between the windings and the case under normal ambient temperature and humidity.
Dielectric Strength		No abnormalities are observed, even when applying voltage between the windings and the case for 1 minute under normal ambient temperature and humidity with the following conditions. • Frame size 42 mm max., PKP262 : 0.5 kVAC 50/60 Hz • Frame size 50 mm min.: 1.0 kVAC 50/60 Hz • PKP29 : 1.5 kVAC 50/60 Hz
Operating Environment (In operation)	Ambient Temperature	-10~+50°C (Non-freezing) [0~+40°C for Flat Type with Harmonic Gear]
	Ambient Humidity	85% or less (Non-condensing)
	Atmosphere	No corrosive gases or dust. The product should not be exposed to water, oil or other liquids.
Temperature Rise		Winding temperature rise 80°C (144°F) max. (Based on Oriental Motor's internal measurement conditions)
Stop Position Accuracy*1		±3 min (±0.05°) [±5 min (±0.083°) for PKP21 , PKP242 and PKP262 , ±2 min (±0.034°) for PV26 and PV26 □ D]
Shaft Runout		0.05 T.I.R. (mm)*4
Radial Play*2		0.025 mm Max. (Load 5 N)
Axial Play*3		0.075 mm Max. (Load 10 N) [Load 1 N for PKP21 □, Load 2.5 N for PKP22 □, PKP242 and PKP262]
Concentricity of Installation Pilot to the Shaft		0.075 T.I.R. (mm)*4
Perpendicularity of Installation Surface to the Shaft		0.075 T.I.R. (mm)*4

*1 This value is for a full step under no load. (The value changes with the size of the load.)

*2 Radial Play: Displacement in shaft position in the radial direction when a 5 N load is applied perpendicular to the tip of the motor shaft.

*3 Axial Play: Displacement in shaft position in the axial direction when a 10 N (**PKP21**□ is 1 N, **PKP22**□, **PKP242** and **PKP262** are 2.5 N) load is applied to the motor shaft in the axial direction.

*4 T. I. R. (Total Indicator Reading): The total dial gauge reading when the measurement section is rotated once around the reference axis center.

Note

- Please detach the motor and driver when measuring insulation resistance, performing a dielectric voltage withstand test, etc. Also, do not conduct these tests on the motor encoder section.

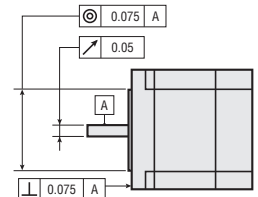

Electromagnetic Brake Specifications

Product Name	PKP22	PKP23, PKP24	PKP26	PKP26□ M2	
Type	Power Off Activated Type				
Power Supply Voltage	24 VDC±5%				
Power Supply Current	A	0.05	0.07	0.23	0.18
Static Friction Torque	N·m (oz·in)	0.08 (11.3)	0.3 (42)	1.5 (213)	0.8 (113.3)
Brake Activation Time	ms	20			
Brake Release Time	ms	50			
Time Rating	Continuous				

Encoder Specifications

Encoder Product Name	R2EL	R2FL
Resolution	200P/R	400P/R
Output Circuit Type	Line driver*	
Output Mode	Incremental	
Output Signals	A phase, B phase, Z phase (3ch)	
Power Supply Voltage	5 VDC±10%	
Current	30 mA max.	

- A voltage output type of encoder output circuit is also available. For details, please contact your nearest Oriental Motor sales office.
- *26C31or Equivalent

Rotation Direction

This indicates the rotation direction when viewed from the output shaft side of the motor. The rotation direction of the output gear shaft relative to the standard type motor output shaft varies depending on the gear type and gear ratio. Please check the following table.

Geared Type		Gear Ratio	The rotation direction when viewed from the output shaft side of the motor
SH Geared Type	Frame Size 28 mm (1.10 in.)	7.2, 36	Same direction
	Frame Size 42 mm (1.65 in.), 60 mm (2.36 in.)	9, 10, 18	Reverse direction
		3.6, 7.2, 9, 10	Same direction
		18, 36	Reverse direction
CS Geared Type	Frame Size 42 mm (1.65 in.)	5, 10, 15, 20	Same direction
Flat Type with Harmonic Gears		50, 100	Reverse direction

Standard Type Motor

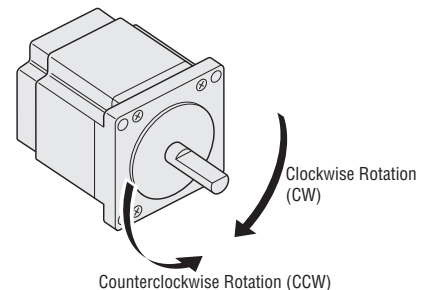

Permissible Radial Load and Permissible Axial Load

Unit: N (lbs.)

Type	Motor Frame Size	Product Name	Gear Ratio	Permissible Radial Load					Permissible Axial Load
				Distance from Shaft End [mm (in.)]					
				0 [0]	5 [0.2]	10 [0.39]	15 [0.59]	20 [0.79]	
Standard Type	20 [0.79]	PKP213, PKP214	-	12 (2.7)	15 (3.3)	-	-	-	3 (0.67)
	28 [1.10]	PKP223, PKP225		25 (5.6)	34 (7.6)	52 (11.7)	-	-	5 (1.12)
	35 [1.38]	PKP233, PKP235		20 (4.5)	25 (5.6)	34 (7.6)	52 (11.7)	-	10 (2.2)
	42 [1.65]	PKP243, PKP244, PKP245, PKP246		20 (4.5)	25 (5.6)	34 (7.6)	52 (11.7)	-	10 (2.2)
		PKP243□2, PKP244□2, PKP245□2, PKP246□2		35 (7.8)	44 (9.9)	58 (13)	85 (19.1)	-	15 (3.3)
	50 [1.97]	PKP254, PKP256, PKP258		61 (13.7)	73 (16.4)	90 (20)	110 (24)	-	20 (4.5)
	56.4 [2.22]	PKP264, PKP266, PKP268		61 (13.7)	73 (16.4)	90 (20)	110 (24)	160 (36)	20 (4.5)
		PKP264□2, PKP266□2, PKP268□2		90 (20)	100 (22)	130 (29)	180 (40)	270 (60)	30 (6.7)
60 [2.36]	PV264, PV266, PV267, PV269	50 (11.2)	60 (13.5)	75 (16.8)	100 (22)	150 (33.7)	20 (4.5)		
85 [3.35]	PKP296, PKP299, PKP2913	260 (58)	290 (65)	340 (76)	390 (87)	480 (108)	60 (13.5)		
High-Resolution Type	42 [1.65]	PKP243, PKP244	-	20 (4.5)	25 (5.6)	34 (7.6)	52 (11.7)	-	10 (2.2)
		PKP243□2, PKP244□2, PKP245□2, PKP246□2		35 (7.8)	44 (9.9)	58 (13)	85 (19.1)	-	15 (3.3)
	56.4 [2.22]	PKP264, PKP266, PKP268		61 (13.7)	73 (16.4)	90 (20)	110 (24)	160 (36)	20 (4.5)
Flat Type, Standard	42 [1.65]	PKP242	-	20 (4.5)	25 (5.6)	34 (7.6)	-	-	5 (1.12)
	60 [2.36]	PKP262		20 (4.5)	25 (5.6)	34 (7.6)	-	-	5 (1.12)
Flat Type with Harmonic Gears	51 mm	PKP242	50, 100	-	-	-	-	-	200 (44.9)
	61 mm	PKP262		-	-	-	-	-	450 (101)
SH Geared Type	28 [1.10]	PKP223	7.2, 9, 10, 18, 36	15 (3.3)	17 (3.8)	20 (4.5)	23 (5.1)	-	10 (2.2)
	42 [1.65]	PKP243	3.6, 7.2, 9, 10, 18, 36	10 (2.2)	15 (3.3)	20 (4.5)	30 (6.7)	-	15 (3.3)
	60 [2.36]	PKP264	3.6, 7.2, 9, 10	30 (6.7)	40 (9)	50 (11.2)	60 (13.5)	70 (15.7)	30 (6.7)
18, 36		80 (18)	100 (22)	120 (27)	140 (31)	160 (36)			
CS Geared Type	42 [1.65]	PKP243	5, 10, 15, 20	59 (13)	68 (15)	80 (18)	96 (21)	-	40 (9)

Radial Load and Axial Load

Distance from Shaft End [mm]

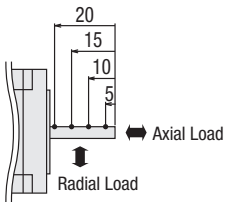

Permissible Moment Load of Flat Type with Harmonic Gears

If an eccentric load is applied to the output flange-installation surface, load moment acts on the bearing.

Please confirm that the axial load and load moment are within the specification values using the following formula.

Product Name	Gear Ratio	Permissible Axial Load [N (lb.)]	Permissible Moment Load [N-m (lb-in)]	Constant a [m (in.)]
PKP242-H□	50, 100	200 (44.9)	8.5 (75.2)	0.0129 (0.5)
PKP262-H□S	50, 100	450 (101)	10.1 (89.3)	0.0140 (0.55)

m: Load mass (kg)	ΔF : Load applied to output flange face (N)
g: Gravitational acceleration (m/s ²)	Fs: Permissible axial load (N)
F: External force (N)	L: Overhung distance (m)
L: Overhung distance (m)	ΔM : Load moment (N-m)
a: Constant (m)	M: Permissible moment load (N-m)

Example 1: When external force F (N) is applied to the L (m) overhung position in the horizontal direction from the center of the output flange

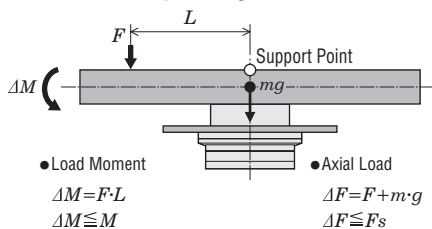

Example 2: When external force F (N) is applied to the L (m) overhung position in the vertical direction from the output flange-installation surface

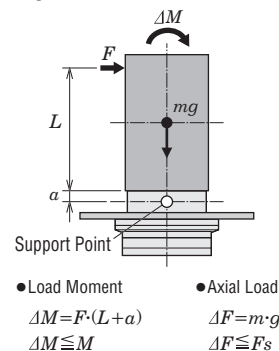

2-Phase Motors PKP

Features Product Line

Product Number Product Line

Standard Type

High-Resolution Type

Flat Type

SH Geared Type

CS Geared Type

General Specifications/ Inner Wiring Diagram of Motor

5-Phase Motors PKP

Features Product Line

Product Number Product Line

Standard Type

High-Resolution Type

TS Geared Type

General Specifications/ Inner Wiring Diagram of Motor

Driver for 2-Phase/ 5-Phase Motors

Accessories

Accuracy of Flat Type with Harmonic Gears

Motor Frame Size

20 mm (0.79 in.)

28 mm (1.10 in.)

35 mm (1.38 in.)

42 mm (1.65 in.)

50 mm (1.97 in.)
51 mm (2.01 in.)

56.4 mm (2.22 in.)

60 mm (2.36 in.)
61 mm (2.40 in.)

85 mm (3.35 in.)

Principle and Structure

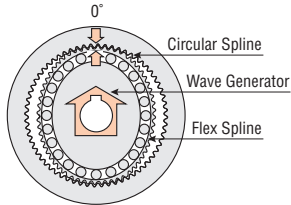

Accuracy

Unlike the conventional spur gear gearhead, the harmonic gear has no backlash. The harmonic gear has many teeth in simultaneous meshing engagement, and is designed to average out the effects of tooth pitch error and cumulative pitch error on rotation accuracy to ensure high positioning accuracy. Also, harmonic gears have high gear ratio, so that the torsion when the load torque is applied to the output shaft is much smaller than a single motor and other geared motor, and the rigidity is high. High rigidity is less subject to load fluctuation and enables stable positioning. When the high positioning accuracy and rigidity are required, refer to the following characteristics.

Angular Transmission Accuracy

Angular transmission error is the difference between the theoretical rotation angle of the output shaft, as calculated from the input pulse count, and actual rotation angle. Represented as the difference between the min. value and max. value in the set of measurements taken for a single rotation of the output shaft, starting from an arbitrary position.

Product Name	Angular Transmission Accuracy [arcmin]
PKP242-H□	2 (0.034°)
PKP262-H□S	1.5 (0.025°)

● Values under no load conditions (gear reference values)

Torque – Torsion Characteristics

In actual applications, there is always frictional load, and displacement is produced as a result of this frictional load. If the frictional load is constant, the displacement will be constant for unidirectional operation. However, in bidirectional operation, double the displacement is produced over a round trip. This displacement can be estimated from the following torque – torsion characteristics.

This displacement occurs when an external force is applied as the gear is stopped, or when the gear is driven under a frictional load. The slope can be approximated with the spring constant in the following 3 classes, depending on the size of the load torque, and can be estimated through calculation.

1. Load torque T_L is T_1 max.

$$\theta = \frac{T_L}{K_1} \text{ [min]}$$

2. Load torque T_L exceeds T_1 but is less than T_2

$$\theta = \theta_1 + \frac{T_L - T_1}{K_2} \text{ [min]}$$

3. Load torque T_L exceeds T_2

$$\theta = \theta_2 + \frac{T_L - T_2}{K_3} \text{ [min]}$$

The torsion angle of the harmonic gear alone is calculated according to the size of the load torque.

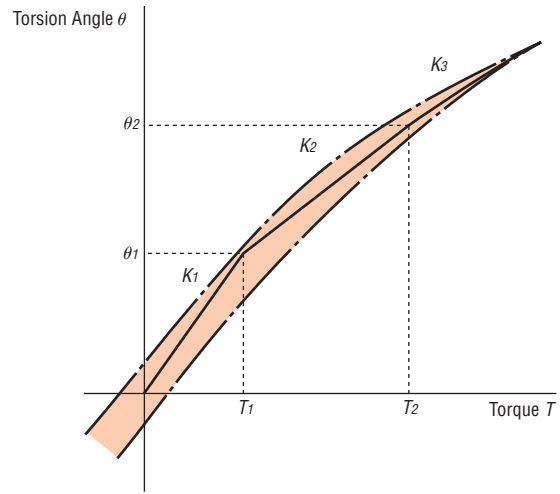

Torsion Angle – Torque Characteristics

Values for Determining Torsion Angle

Product Name	Item	Gear Ratio	T_1	K_1	θ_1	T_2	K_2	θ_2	K_3
			N-m	N-m/min	min	N-m	N-m/min	min	N-m/min
PKP242-H50	50	0.29	0.13	2.3	0.75	0.19	4.5	0.24	
	100	0.29	0.26	1.1	0.75	0.29	2.8	0.35	
PKP262-H50S	50	0.8	0.64	1.2	2	0.87	2.8	0.93	
	100	0.8	0.79	1	2	0.99	2.1	1.28	

Inner Wiring Diagram for Motor and Rotation Direction

Inner Wiring Diagram

Motor Model Type	Connection Diagram/Pin Arrangement		
Model A	<p>① Bipolar 4 lead wires</p> <p>● The colors in the connection diagram are the colors of connection cables, sold separately.</p>	<p>② Unipolar 5 lead wires</p>	<p>• Pin arrangement</p>
Model B	<p>③ Bipolar 4 lead wires</p> <p>● The colors in the connection diagram are the colors of connection cables, sold separately.</p>	<p>④ Unipolar 6 lead wires</p>	<p>• Pin arrangement</p>
Model C	<p>⑤ Bipolar 4 lead wires</p>	<p>⑥ Unipolar 5 lead wires</p>	<p>⑦ Unipolar 6 lead wires</p> <p>• Pin arrangement</p> <p>Motor lead wire colors: Blue, white, red, black, yellow, green</p>

Rotation Direction

If excitation occurs in the following order, the motor rotates in the CW direction when viewed from the output shaft side.

•Bipolar

STEP	Black	Green	Red	Blue
1	-	+	+	-
2	-	+	-	+
3	+	-	-	+
4	+	-	+	-

•Unipolar

STEP	A	\bar{A}	B	\bar{B}
1	ON		ON	
2		ON	ON	
3		ON		ON
4	ON			ON

2-Phase Motors PKP

Features Product Line

Product Number Product Line

Standard Type

High-Resolution Type

Flat Type

SH Geared Type

CS Geared Type

General Specifications/ Inner Wiring Diagram of Motor

5-Phase Motors PKP

Features Product Line

Product Number Product Line

Standard Type

High-Resolution Type

TS Geared Type

General Specifications/ Inner Wiring Diagram of Motor

Driver for 2-Phase/ 5-Phase Motors

Accessories

20 mm (0.79 in.)

28 mm (1.10 in.)

35 mm (1.38 in.)

42 mm (1.65 in.)

50 mm (1.97 in.)
51 mm (2.01 in.)

56.4 mm (2.22 in.)

60 mm (2.36 in.)
61 mm (2.40 in.)

85 mm (3.35 in.)

5-Phase Stepper Motors PKP Series

For detailed information about regulations and standards, please see the Oriental Motor website.

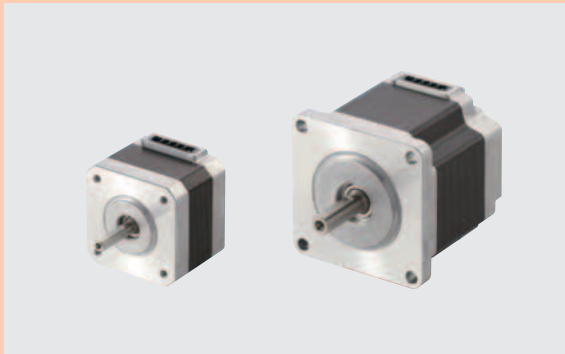

This is a high torque and low vibration stepper motor with a basic step angle of 0.72° (resolution of 500 steps per revolution).

High positioning accuracy is possible through low vibration and reduced noise.

(A separate dedicated driver is required to operate each motor.)



See Full Product Details Online
www.orientalmotor.com

Manual

Specifications

Dimensions

CAD

Characteristics

Connection and Operation

Features

High Accuracy

Since the step angle of the **PKP** Series 5-Phase Stepper Motor is at 0.72° (high-resolution type at 0.36°) and the stopping accuracy is at $\pm 0.05^\circ$, highly accurate positioning is possible. In addition, the stop position accuracy controlled by a microstep driver has almost the same high accuracy as that controlled by a full-step driver.

General 2-Phase Stepper Motor

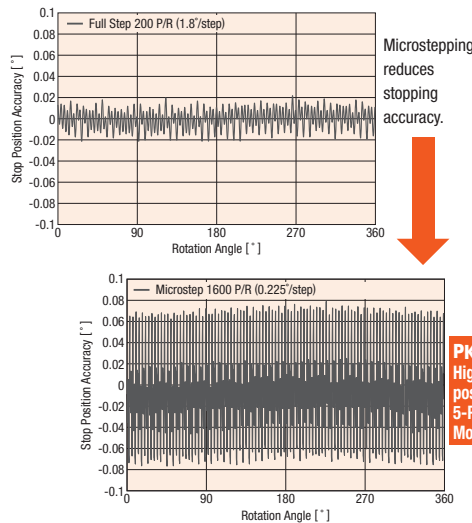

5-Phase Stepper Motor **PKP** Series

(Driver: **CVD** driver for 5-Phase Stepper Motor)

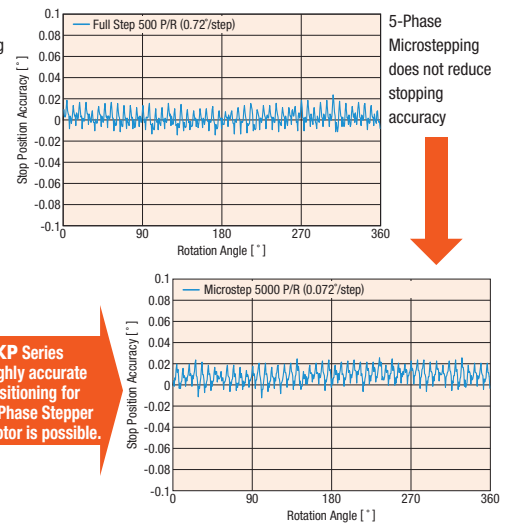

Low Vibration and Reduced Noise

Because the basic step angle is small at 0.72° (0.36° for high-resolution type), the vibrations and noise are lower than the 2-Phase stepper motor. Also, vibrations and noise can be further reduced by an advanced microstep driver.

Example of 2-Phase Stepper Motor Vibration Characteristics

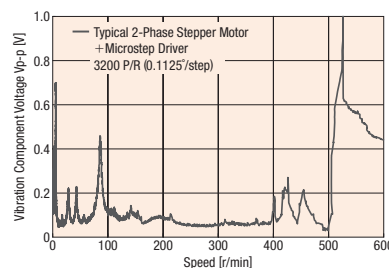

PKP Series Vibration characteristics for 5-Phase Stepper Motor have been further improved.

Example of 5-Phase Stepper Motor Vibration Characteristics

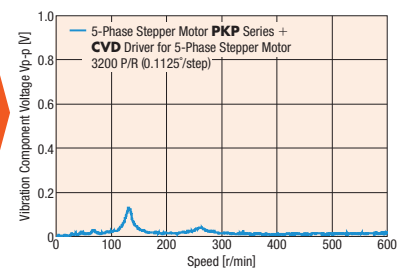

Product Line Utilizing a Compact and Flat Connector

We offer a product line utilizing compact and flat connectors. The motor cable outlet direction points upward, which increases the degrees of freedom for the cable outlet direction.

● The connector configuration differs by motor. For more details, check the motor dimensions.

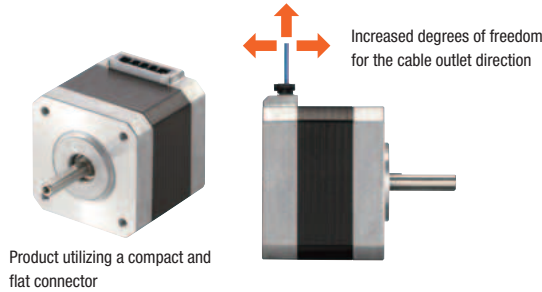

Product Line

—: Not Offered in This Product Line

Type (Basic step angle)	Features	Frame Size				
		20 mm (0.79 in.)	28 mm (1.10 in.)	42 mm (1.65 in.)	56.4 mm (2.22 in.)	60 mm (2.36 in.)
Standard Type (0.72°)	<ul style="list-style-type: none"> Standard model High torque, low vibration 					
High-Resolution Type (0.36°)	<ul style="list-style-type: none"> Double the resolution of the standard type motor High positioning accuracy and reduced vibration 	—	—		—	
Standard Type with Encoder (0.72°)	<ul style="list-style-type: none"> Encoder resolution 500 P/R, A, B, and Z (3 ch) output signals Utilizes a compact encoder Encoder with superior noise resistance and a line driver (differential) output 		—			
TS Geared Type (0.024~0.2°)	<ul style="list-style-type: none"> Spur Gear Mechanism A wide variety of low gear ratios, high-speed operations Gear ratio types: 3.6, 7.2, 10, 20, 30 	—	—		—	

*This is the PK Series of a conventional product.

2-Phase Motors PKP

Features Product Line

Product Number Product Line

Standard Type

High-Resolution Type

Flat Type

SH Geared Type

CS Geared Type

General Specifications/ Inner Wiring Diagram of Motor

5-Phase Motors PKP

Features Product Line

Product Number Product Line

Standard Type

High-Resolution Type

TS Geared Type

General Specifications/ Inner Wiring Diagram of Motor

Driver for 2-Phase/ 5-Phase Motors

Accessories

20 mm
(0.79 in.)

28 mm
(1.10 in.)

35 mm
(1.38 in.)

42 mm
(1.65 in.)

50 mm
(1.97 in.)
51 mm
(2.01 in.)

56.4 mm
(2.22 in.)

60 mm
(2.36 in.)
61 mm
(2.40 in.)

85 mm
(3.35 in.)

System Configuration

These accessories allow 5-Phase stepper motors in the **PKP** Series to be used for various operations. Motors and connection cables must be ordered individually.

5-Phase PKP Series

Motor



The connection cable is required for the connector-coupled type motor.

Connection Cable

Sold Separately

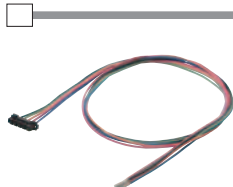

See motor specification page

Required Drive Products (Sold separately)



Page 90

Programmable Controller*

Controller

A pulse generator is available.



Page 102

Accessories



MCV Couplings
Page 100



Motor Mounting Brackets
Page 100

*Not supplied.

● Example of System Configuration

5-Phase PKP Series	
Motor	Connection Cable
PKP566FN24A2	LC5N06E
\$75.00	\$6.00

+

Accessories	
Motor Mounting Brackets	Flexible Couplings
PALW2P-5	MCV190808
\$17.00	\$72.00

● The system configuration shown above is an example. Other combinations are also available.

Product Number

Motor

◇ Frame Size 20 mm (0.79 in.), 85 mm (3.35 in.)

Standard Type

PK 5 1 3 P A

① ② ③ ④ ⑤ ⑧

◇ Standard Type with Encoder

PK 5 1 3 P A - R2G L

① ② ③ ④ ⑤ ⑧ ⑨ ⑩

◇ Frame Size 28 mm (1.10 in.), 42 mm (1.65 in.), 56.4 mm (2.22 in.), 60 mm (2.36 in.)

Standard Type, High Resolution Type

PKP 5 6 6 F N 24 A 2

① ② ③ ④ ⑤ ⑦ ⑧ ⑨ ⑩

PKP 5 4 4 M N 18 A

① ② ③ ④ ⑥ ⑦ ⑧ ⑨

◇ Standard Type with Encoder

PKP 5 6 6 F N 24 A 2 - R2G L

① ② ③ ④ ⑤ ⑦ ⑧ ⑨ ⑩ ⑪ ⑫

TS Geared Type

PKP 5 4 3 N 18 A 2 - TS 30

① ② ③ ④ ⑤ ⑥ ⑦ ⑧ ⑨ ⑩

Driver

For details about drivers refer to page 94.

Connection Cable

◇ Motor Connection Cable

LC 5 N 06 E

① ② ③ ④ ⑤

◇ Encoder Connection Cable

LC E 08 A - 006

① ② ③ ④ ⑤

①	Series Name	PK: PK Series
②	5: 5-Phase	
③	Motor Frame Size	1: 20 mm (0.79 in.) 9: 85 mm (3.35 in.)
④	Motor Case Length	
⑤	Motor Classification	
⑥	Motor Specifications	Blank: Standard Specifications H: High-Speed Specifications
⑦	Number of Lead Wires	N: 5
⑧	Shaft	A: Single Shaft B: Double Shaft
⑨	Encoder Resolution	R2G: 500 P/R
⑩	Encoder Output Circuit Type	L: Line Driver Output Blank: Voltage Output
⑪	Cable Type	Blank: Connector Type W: Lead Wire Type

①	Series Name	PKP: PKP Series
②	5: 5-Phase	
③	Motor Frame Size	2: 28 mm (1.10 in.) 4: 42 mm (1.65 in.) 6: 56.4 mm (2.22 in.)* [60mm (2.36 in.) when the Motor Identification is F]
④	Motor Case Length	
⑤	Motor Identification	F: Motor Frame Size 60 mm (2.36 in.)
⑥	Motor Type	Blank: Standard Type M: High-Resolution Type
⑦	Number of Lead Wires	N: 5
⑧	Motor Winding Specifications	
⑨	Shaft	A: Single Shaft B: Double Shaft
⑩	Reference Number	
⑪	Encoder Resolution	R2G: 500 P/R
⑫	Encoder Output Circuit Type	L: Line Driver Output Blank: Voltage Output

*A product with a shaft diameter of $\phi 6.35$ mm is also available.
For details, please contact the nearest Oriental Motor sales office.

①	Series Name	PKP: PKP Series
②	5: 5-Phase	
③	Motor Frame Size	4: 42 mm (1.65 in.) 6: 56.4 mm (2.22 in.)
④	Motor Case Length	
⑤	Number of Lead Wires	N: 5
⑥	Motor Winding Specification	
⑦	Shaft	A: Single Shaft B: Double Shaft
⑧	Reference Number	
⑨	Geared Type	TS: TS Geared Type
⑩	Gear Ratio	

①	Cable	LC: Lead Wire with Connector
②	5: 5-Phase	
③	Cable Type	N: 5
④	Cable Length	06: 0.6 m (2 ft.) 10: 1 m (3.3 ft.)
⑤	Reference Number	

①	Cable	LC: Lead Wire with Connector
②	Cable Type	E: Encoder Cable
③	Applicable Model	08: Line Driver Output 05: Voltage Output
④	Reference Number	
⑤	Cable Length	006: 0.6 m (2 ft.)

2-Phase
Motors
PKP

Features
Product
Line

Product
Number
Product Line

Standard
Type

High-
Resolution
Type

Flat Type

SH
Geared
Type

CS
Geared
Type

General
Specifications/
Inner Wiring
Diagram of Motor

5-Phase
Motors
PKP

Features
Product
Line

Product
Number
Product Line

Standard
Type

High-
Resolution
Type

TS
Geared
Type

General
Specifications/
Inner Wiring
Diagram of Motor

Driver for
2-Phase/
5-Phase Motors

Accessories

Motor Frame Size

20 mm (0.79 in.)

28 mm (1.10 in.)

35 mm (1.38 in.)

42 mm (1.65 in.)

50 mm (1.97 in.)
51 mm (2.01 in.)

56.4 mm (2.22 in.)

60 mm (2.36 in.)
61 mm (2.40 in.)

85 mm (3.35 in.)

Product Line

A connection cable is required for connector-coupled motors.

Motors, drivers, and cables must be ordered individually. Refer to motor specification page for connection cable.

Motor

Standard Type

Product Name (Single Shaft)	List Price	Product Name (Double Shaft)	List Price
PK513PA	\$100.00	PK513PB	\$105.00
PKP523N12A	\$64.00	PKP523N12B	\$66.00
PKP525N12A	\$74.00	PKP525N12B	\$76.00
PKP543N18A2	\$52.00	PKP543N18B2	\$54.00
PKP544N18A2	\$54.00	PKP544N18B2	\$56.00
PKP545N18A2	\$61.00	PKP545N18B2	\$64.00
PKP546N18A2	\$63.00	PKP546N18B2	\$66.00
PKP564N28AA2	\$63.00	PKP564N28BA2	\$66.00
PKP566N28AA2	\$69.00	PKP566N28BA2	\$72.00
PKP568N28AA2	\$86.00	PKP568N28BA2	\$90.00
PKP564FN24A2	\$69.00	PKP564FN24B2	\$72.00
PKP564FN38A2	\$69.00	PKP564FN38B2	\$72.00
PKP566FN24A2	\$75.00	PKP566FN24B2	\$78.00
PKP566FN38A2	\$75.00	PKP566FN38B2	\$78.00
PKP569FN24A2	\$92.00	PKP569FN24B2	\$95.00
PKP569FN38A2	\$92.00	PKP569FN38B2	\$95.00

High-Resolution Type

Product Name (Single Shaft)	List Price	Product Name (Double Shaft)	List Price
PKP544MN18A	\$54.00	PKP544MN18B	\$56.00
PKP546MN18A	\$62.00	PKP546MN18B	\$64.00
PKP564FMN24A	\$61.00	PKP564FMN24B	\$63.00
PKP566FMN24A	\$67.00	PKP566FMN24B	\$69.00
PKP569FMN24A	\$90.00	PKP569FMN24B	\$93.00

TS Geared Type

Product Name (Single Shaft)	List Price	Product Name (Double Shaft)	List Price
PKP544N18A2-TS3.6	\$198.00	PKP544N18B2-TS3.6	\$200.00
PKP544N18A2-TS7.2	\$198.00	PKP544N18B2-TS7.2	\$200.00
PKP544N18A2-TS10	\$214.00	PKP544N18B2-TS10	\$216.00
PKP543N18A2-TS20	\$214.00	PKP543N18B2-TS20	\$216.00
PKP543N18A2-TS30	\$214.00	PKP543N18B2-TS30	\$216.00
PKP566N28A2-TS3.6	\$229.00	PKP566N28B2-TS3.6	\$232.00
PKP566N28A2-TS7.2	\$229.00	PKP566N28B2-TS7.2	\$232.00
PKP566N28A2-TS10	\$245.00	PKP566N28B2-TS10	\$248.00
PKP564N28A2-TS20	\$245.00	PKP564N28B2-TS20	\$248.00
PKP564N28A2-TS30	\$245.00	PKP564N28B2-TS30	\$248.00

Driver

For details about drivers refer to page 94.

Standard Type with Encoder

Product Name	List Price	Product Name	List Price
		PK513PA-R2GL	\$216.00
PKP543N18A2-R2G	\$109.00	PKP543N18A2-R2GL	\$109.00
PKP544N18A2-R2G	\$112.00	PKP544N18A2-R2GL	\$112.00
PKP545N18A2-R2G	\$118.00	PKP545N18A2-R2GL	\$118.00
PKP546N18A2-R2G	\$121.00	PKP546N18A2-R2GL	\$121.00
PKP564N28A2-R2G	\$121.00	PKP564N28A2-R2GL	\$121.00
PKP566N28A2-R2G	\$127.00	PKP566N28A2-R2GL	\$127.00
PKP568N28A2-R2G	\$144.00	PKP568N28A2-R2GL	\$144.00
PKP564FN24A2-R2G	\$127.00	PKP564FN24A2-R2GL	\$127.00
PKP564FN38A2-R2G	\$127.00	PKP564FN38A2-R2GL	\$127.00
PKP566FN24A2-R2G	\$132.00	PKP566FN24A2-R2GL	\$132.00
PKP566FN38A2-R2G	\$132.00	PKP566FN38A2-R2GL	\$132.00
PKP569FN24A2-R2G	\$150.00	PKP569FN24A2-R2GL	\$150.00
PKP569FN38A2-R2G	\$150.00	PKP569FN38A2-R2GL	\$150.00

Motor Connection Cable

For the applicable motor of the connection cable, refer to the dimension page of each product. Some cables that can be directly connected to the recommended driver are also available.

Included

Type	Included	Parallel Key	Motor Mounting Screw	Operating Manual
Standard		—	—	1 Copy
High-Resolution		—	—	
TS Geared	Frame Size 42 mm (1.65 in.) Frame Size 60 mm (2.36 in.)	1 piece	M4×60 P0.7 (4 pcs.)	

How to Read Specifications

Maximum Holding Torque	: This is the maximum holding torque (holding force) the motor has when power is supplied (at rated current) but the motor is not rotating. (With geared types, the value of holding torque considers the permissible strength of the gear.)
Permissible Torque	: The permissible torque represents the maximum value limited by the mechanical strength of the output gear shaft when operated at a constant speed.
Maximum Instantaneous Torque	: This is the maximum torque that can be applied to the gear output shaft during acceleration/deceleration such when an inertial load is started and stopped.
Holding Torque at Motor Standstill	: Holding torque when the automatic current cutback function is active is shown.

Standard Type

Frame Size 20 mm (0.79 in.)

2-Phase Motors
PKP

Features Product Line

Product Number Product Line

Standard Type

High-Resolution Type

Flat Type

SH Geared Type

CS Geared Type

General Specifications/ Inner Wiring Diagram of Motor

5-Phase Motors
PKP

Features Product Line

Product Number Product Line

Standard Type

High-Resolution Type

TS Geared Type

General Specifications/ Inner Wiring Diagram of Motor

Driver for 2-Phase/ 5-Phase Motors

Accessories

Specifications

Product Name		Maximum Holding Torque N·m (oz-in)	Rotor Inertia J: kg·m ² (oz-in ²)	Rated Current A/Phase	Winding Resistance Ω/Phase	Basic Step Angle	Recommended Driver Product Name*
Single Shaft	Double Shaft						
PK513PA	PK513PB	0.0231 (3.28)	1.6×10^{-7} (0.0088)	0.35	3.5	0.72°	CVD503BR-K

*See page 94 for details on the recommended drivers.

Speed – Torque Characteristics (Reference Values) fs: Max. Starting Frequency

PK513PA/PK513PB

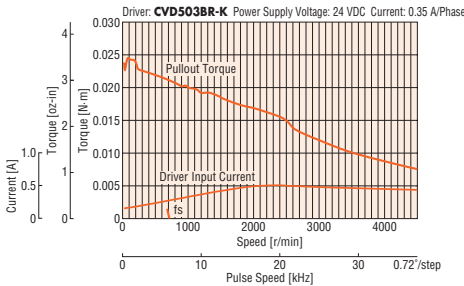

Note

- Data for the speed – torque characteristics is based on Oriental Motor's internal measurement conditions. If the conditions are changed, the characteristics may also change as a result.
- Depending on the driving conditions, a considerable amount of heat may be generated by the motor. Be sure to keep the motor case temperature at 100°C (212°F) max.
- Set the current of the driver so that it does not exceed the rated current of the motor.

Dimensions Unit: mm (in.)

● Motor

2D & 3D CAD

Product Name	Mass kg (lb.)	2D CAD
PK513PA	0.05 (0.110)	B316
PK513PB		

● Applicable Connectors

- Connector Housing: 51065-0500(Molex)
- Contact: 50212-8100(Molex)
- Crimp Tool: 57176-5000(Molex)

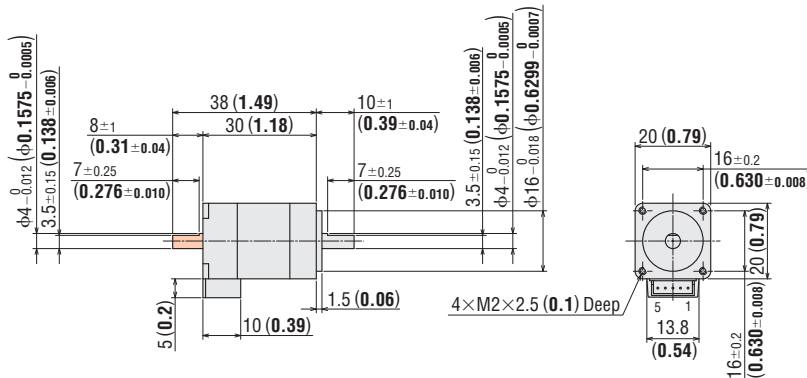

- These dimensions are for double shaft motors.
For single shaft motors, ignore the shaft in the areas.

Motor Pin Assignments

Motor Pin Assignments: Model B

- Refer to page 88 for inner wiring diagram of motor.

● Connection Cable(Sold separately)

◇ Motor Connection Cable

Product Name	Length L m (ft.)
LC5N06A	0.6 (2)
LC5N10A	1 (3.3)

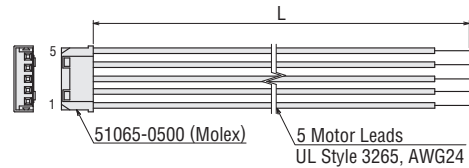

Standard Type with Encoder

Frame Size 20 mm (0.79 in.)

Specifications

Product Name	Maximum Holding Torque N·m (oz-in)	Rotor Inertia J: kg·m ² (oz-in ²)	Rated Current A/Phase	Winding Resistance Ω/Phase	Basic Step Angle	Recommended Driver Product Name*
PK513PA-R2G <input type="checkbox"/>	0.0231 (3.28)	1.66×10 ⁻⁷ (0.0091)	0.35	3.5	0.72°	CVD503BR-K

- A code **L** (line driver output) indicating the encoder output circuit type is entered where the box is located within the product name. The voltage output type will have no " " in the product name.
- See page 88 for encoder specifications.
- *See page 94 for details on the recommended drivers.

Speed – Torque Characteristics (Reference Values) fs: Max. Starting Frequency

PK513PA-R2GL/PK513PA-R2G

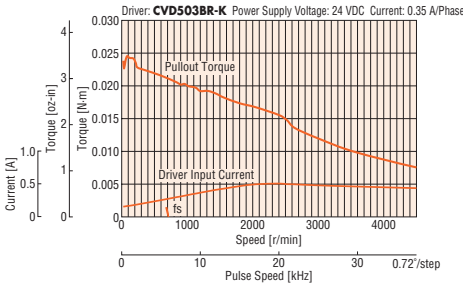

Note

- Data for the speed – torque characteristics is based on Oriental Motor's internal measurement conditions. If the conditions are changed, the characteristics may also change as a result.
- Depending on the driving conditions, a considerable amount of heat may be generated by the motor. Be sure to keep the motor case temperature at 85°C (185°F) max.
- Set the current of the driver so that it does not exceed the rated current of the motor.

Dimensions Unit: mm (in.)

Motor

2D & 3D CAD

Product Name	Mass kg (lb.)	2D CAD
PK513PA-R2G <input type="checkbox"/>	0.06 (0.132)	B1069

- A code **L** (line driver output) indicating the encoder output circuit type is entered where the box is located within the product name. The voltage output type will have no " " in the product name.

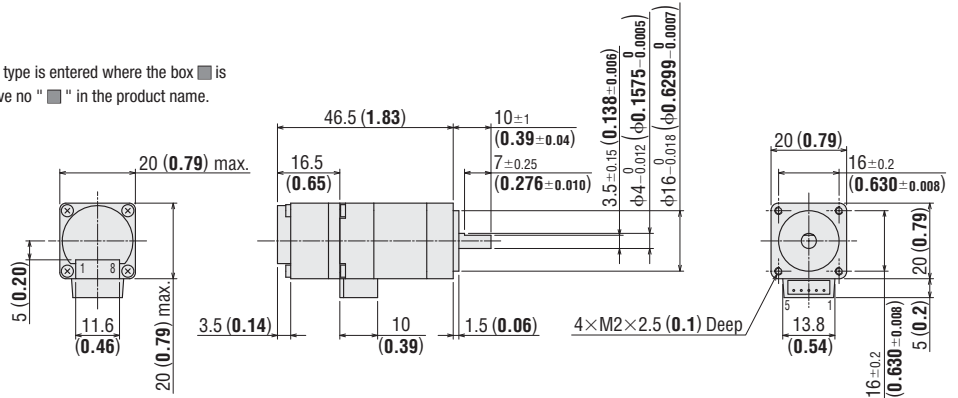

- Applicable Connectors (Molex)

	Motor	Encoder
Connector Housing	51065-0500	51021-0800
Contact	50212-8100	50079-8100
Crimp Tool	57176-5000	57177-5000

Connection Cable (Sold separately)

◇ Motor Connection Cable

Product Name	Length L m (ft.)
LC5N06A	0.6 (2)
LC5N10A	1 (3.3)

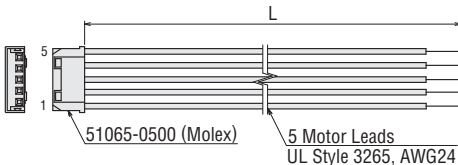

Connection Cable (Included)

◇ Encoder Connection Cable

Encoder Output Circuit Type	Product Name	Length L [m (ft.)]
Line Driver Output Type	LCE08A-006	0.6 (2)
Voltage Output Type	LCE05A-006	

● LCE08A-006

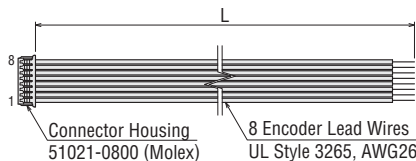

● LCE05A-006

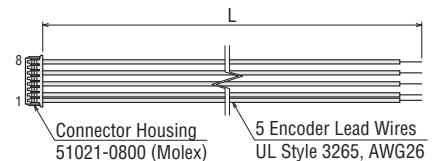

Motor Pin Assignments

Motor Pin Assignments: Model B

- Refer to page 88 for inner wiring diagram of motor.

Standard Type

Frame Size 28 mm (1.10 in.)

2-Phase
Motors
PKP

Specifications

Product Name		Maximum Holding Torque N·m (oz·in)	Rotor Inertia J: kg·m ² (oz·in)	Rated Current A/Phase	Winding Resistance Ω/Phase	Basic Step Angle	Recommended Driver Product Name*
Single Shaft	Double Shaft						
PKP523N12A	PKP523N12B	0.052 (7.3)	9×10^{-7} (0.049)	1.2	0.63	0.72°	CVD512BR-K
PKP525N12A	PKP525N12B	0.091 (12.9)	18×10^{-7} (0.098)		1		

*See page 94 for details on the recommended drivers.

Speed – Torque Characteristics (Reference Values) fs: Max. Starting Frequency

PKP523N12A/PKP523N12B

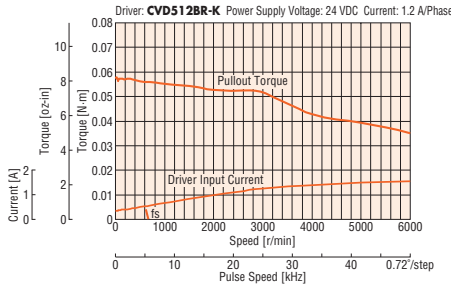

PKP525N12A/PKP525N12B

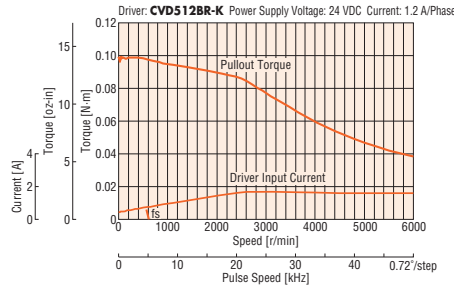

Note

- Data for the speed – torque characteristics is based on Oriental Motor's internal measurement conditions. If the conditions are changed, the characteristics may also change as a result.
- Depending on the driving conditions, a considerable amount of heat may be generated by the motor. Be sure to keep the motor case temperature at 100°C (212°F) max.
- Set the current of the driver so that it does not exceed the rated current of the motor.

Dimensions Unit: mm (in.)

Motor

2D & 3D CAD

Product Name	L1	L2	Mass kg (lb.)	2D CAD
PKP523N12A	32 (1.26)	—	0.11 (0.24)	B1146
PKP523N12B	—	42 (1.65)	—	—
PKP525N12A	51.5 (2.03)	—	0.2 (0.44)	B1147
PKP525N12B	—	61.5 (2.42)	—	—

Applicable Connectors

Connector Housing: 51065-0500 (Molex)
Contact: 50212-8100 (Molex)
Crimp Tool: 57176-5000 (Molex)

Connection Cable (Sold separately)

Motor Connection Cable

Product Name	Length L m (ft.)
LC5N06A	0.6 (2)
LC5N10A	1 (3.3)

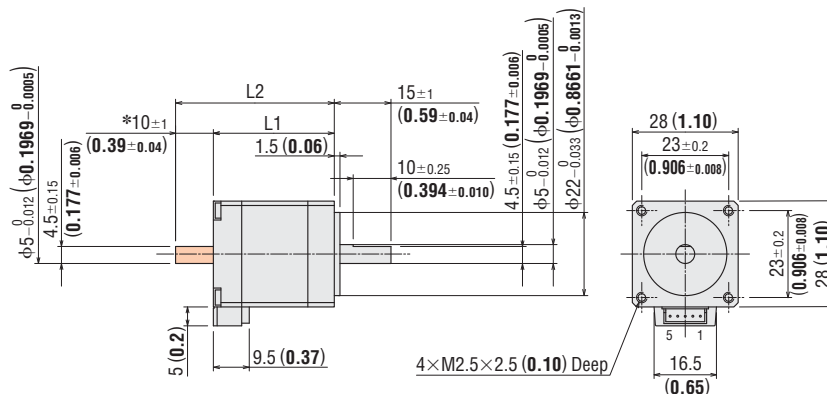
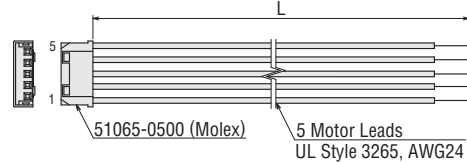

*The length of the shaft flat on the double shaft model is 10±0.25 (0.394±0.010).

● These dimensions are for double shaft motors.

For single shaft motors, ignore the shaft in the areas.

Motor Pin Assignments

Motor Pin Assignments: Model B

- Refer to page 88 for inner wiring diagram of motor.

Features
Product
Line

Product
Number
Product Line

Standard
Type

High-
Resolution
Type

Flat Type

SH
Geared
Type

CS
Geared
Type

General
Specifications/
Inner Wiring
Diagram of Motor

5-Phase
Motors
PKP

Features
Product
Line

Product
Number
Product Line

Standard
Type

High-
Resolution
Type

TS
Geared
Type

General
Specifications/
Inner Wiring
Diagram of Motor

Driver for
2-Phase/
5-Phase Motors

Accessories

Standard Type

Frame Size 42 mm (1.65 in.)

Specifications

Product Name		Maximum Holding Torque N·m (oz·in)	Rotor Inertia J: kg·m ² (oz·in ²)	Rated Current A/Phase	Winding Resistance Ω/Phase	Basic Step Angle	Recommended Driver Product Name*
Single shaft	Double shaft						
PKP543N18A2	PKP543N18B2	0.22 (31)	35×10^{-7} (0.192)	1.8	0.4	0.72°	CVD518BR-K
PKP544N18A2	PKP544N18B2						
PKP545N18A2	PKP545N18B2						
PKP546N18A2	PKP546N18B2	0.37 (52)	71×10^{-7} (0.39)		0.55		
		0.5 (71)	110×10^{-7} (0.6)		0.64		

*See page 94 for details on the recommended drivers.

Speed – Torque Characteristics (Reference Values) fs: Max. Starting Frequency

PKP543N18A2/ PKP543N18B2

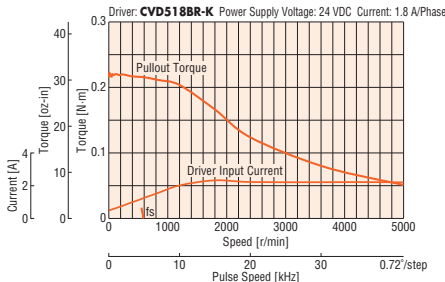

PKP544N18A2/ PKP544N18B2

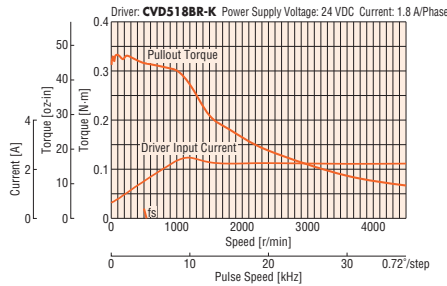

PKP545N18A2/ PKP545N18B2

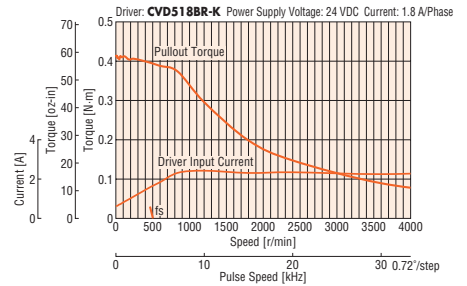

PKP546N18A2/ PKP546N18B2

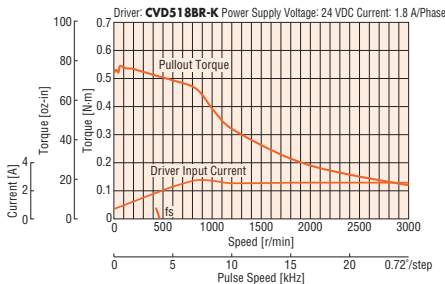

Note

- Data for the speed – torque characteristics is based on Oriental Motor's internal measurement conditions. If the conditions are changed, the characteristics may also change as a result.
- Depending on the driving conditions, a considerable amount of heat may be generated by the motor. Be sure to keep the motor case temperature at 100°C (212°F) max.
- Set the current of the driver so that it does not exceed the rated current of the motor.

Dimensions Unit: mm (in.)

● Motor

2D & 3D CAD

Product Name	L1	L2	Mass kg (lb.)	2D CAD
PKP543N18A2	33	—	0.23 (0.51)	B1264
PKP543N18B2	(1.30)	48 (1.89)		
PKP544N18A2	39	—	0.29 (0.64)	B1265
PKP544N18B2	(1.54)	54 (2.13)		
PKP545N18A2	47	—	0.37 (0.81)	B1266
PKP545N18B2	(1.85)	62 (2.44)		
PKP546N18A2	59	—	0.49 (1.08)	B1267
PKP546N18B2	(2.32)	74 (2.91)		

● Applicable Connectors

Connector Housing: MDF97-5S-3.5C (HIROSE ELECTRIC CO.,LTD)

Contact: MDF97-22SC (HIROSE ELECTRIC CO.,LTD)

Crimp Tool: HT801/MDF97-22S (HIROSE ELECTRIC CO.,LTD)

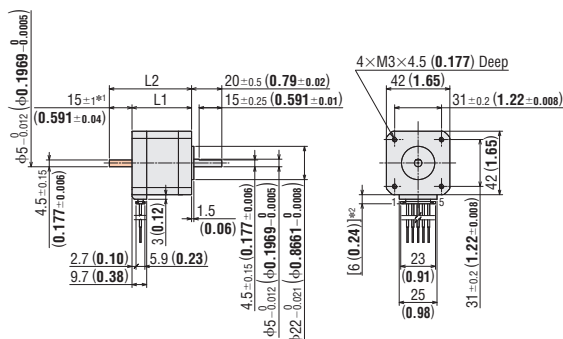

*1 The length of the shaft flat on the double shaft model is 15±0.25 (0.591±0.010)

*2 With connection cable.

● These dimensions are for double shaft motors.

For single shaft motors, ignore the shaft the [] areas.

● Connection Cables (Sold separately)

◇ Motor Connection Cables

Product Name	Length L, m (ft.)
LC5N06E	0.6 (2)
LC5N10E	1 (3.3)

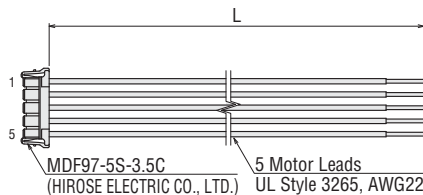

Motor Pin Assignments

Motor Pin Assignments: Model A

● Refer to page 88 for inner wiring diagram of motor.

Standard Type with Encoder

Frame Size 42 mm (1.65 in.)

Specifications

Product Name	Maximum Holding Torque N·m (oz·in)	Rotor Inertia J: kg·m ² (oz·in ²)	Rated Current A/Phase	Winding Resistance Ω/Phase	Basic Step Angle	Recommended Driver Product Name*
PKP543N18A2-R2G ■	0.22 (31)	35×10^{-7} (0.192)	1.8	0.4	0.72°	CVDS18BR-K
PKP544N18A2-R2G ■	0.3 (42)	55×10^{-7} (0.3)		0.48		
PKP545N18A2-R2G ■	0.37 (52)	71×10^{-7} (0.39)		0.55		
PKP546N18A2-R2G ■	0.5 (71)	110×10^{-7} (0.6)		0.64		

● The box ■ in the product name indicates the encoder output circuit type L (line driver output). The voltage output type will have no " ■ " in the product name.

● See page 88 for encoder specification.

*See page 94 for details on the recommended drivers.

Speed – Torque Characteristics (Reference Values) fs: Max. Starting Frequency

PKP543N18A2-R2GL/ PKP543N18A2-R2G

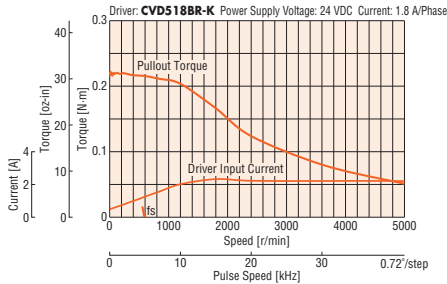

PKP544N18A2-R2GL/ PKP544N18A2-R2G

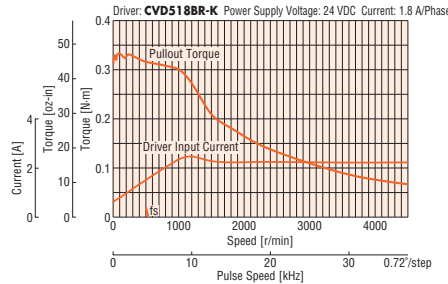

PKP545N18A2-R2GL/ PKP545N18A2-R2G

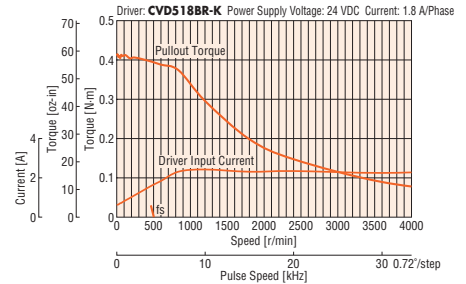

PKP546N18A2-R2GL/ PKP546N18A2-R2G

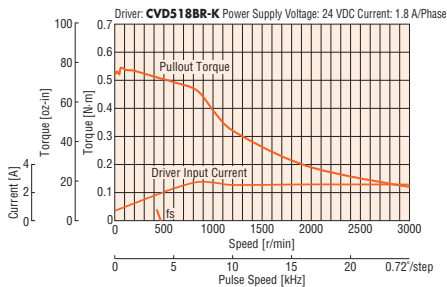

Note

- Data for the speed – torque characteristics is based on Oriental Motor's internal measurement conditions. If the conditions are changed, the characteristics may also change as a result.
- Depending on the driving conditions, a considerable amount of heat may be generated by the motor. Be sure to keep the motor case temperature at 85°C (185°F) max.
- Set the current of the driver so that it does not exceed the rated current of the motor.

Dimensions Unit: mm (in.)

● Motor

2D & 3D CAD

Product Name	L	Mass kg (lb.)	2D CAD
PKP543N18A2-R2G ■	46.5 (1.83)	0.24 (0.53)	B1343
PKP544N18A2-R2G ■	52.5 (2.07)	0.3 (0.66)	B1344
PKP545N18A2-R2G ■	60.5 (2.38)	0.38 (0.84)	B1345
PKP546N18A2-R2G ■	72.5 (2.85)	0.5 (1.1)	B1346

● The box ■ in the product name indicates the encoder output circuit type L (line driver output). The voltage output type will have no " ■ " in the product name.

● Applicable Connector

	Motor (HIROSE ELECTRIC CO.,LTD.)	Encoder (Molex)
Connector Housing	MDF97-5S-3.5C	51021-0800
Contact	MDF97-22SC	50079-8100
Crimp Tool	HT801/MDF97-22S	57177-5000

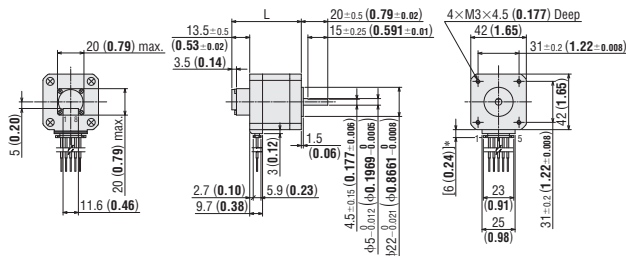

*With connection cable.

Motor Pin Assignments

Motor Pin Assignments: Model A

● Refer to page 88 for inner wiring diagram of motor.

● Connection Cables (Sold separately)

◇ Motor Connection Cables

Product Name	Length L m (ft.)
LC5N06E	0.6 (2)
LC5N10E	1 (3.3)

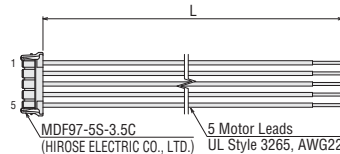

◇ Encoder Connection Cable

Encoder Output Circuit Type	Product Name	Length L [m (ft.)]
Line Driver Output Type	LCE08A-006	0.6 (2)
Voltage Output Type	LCE05A-006	

● LCE08A-006

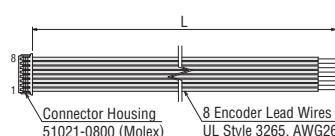

● LCE05A-006

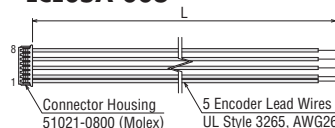

2-Phase
Motors
PKP

Features
Product
Line

Product
Number
Product Line

Standard
Type

High-
Resolution
Type

Flat Type

SH
Geared
Type

CS
Geared
Type

General
Specifications/
Inner Wiring
Diagram of Motor

5-Phase
Motors
PKP

Features
Product
Line

Product
Number
Product Line

Standard
Type

High-
Resolution
Type

TS
Geared
Type

General
Specifications/
Inner Wiring
Diagram of Motor

Driver for
2-Phase/
5-Phase Motors

Accessories

Standard Type

Frame Size 56.4 mm (2.22 in.)

20 mm (0.79 in.)

28 mm (1.10 in.)

35 mm (1.38 in.)

42 mm (1.65 in.)

50 mm (1.97 in.)
51 mm (2.01 in.)

56.4 mm (2.22 in.)

60 mm (2.36 in.)
61 mm (2.40 in.)

85 mm (3.35 in.)

Specifications

Product Name		Maximum Holding Torque N·m (oz-in)	Rotor Inertia J: kg·m ² (oz-in ²)	Rated Current A/Phase	Winding Resistance Ω/Phase	Basic Step Angle	Recommended Driver Product Name*
Single shaft	Double shaft						
PKP564N28AA2	PKP564N28BA2	0.44 (62)	140×10 ⁻⁷ (0.77)	2.8	0.16	0.72°	CVD528BR-K
PKP566N28AA2	PKP566N28BA2	0.81 (115)	270×10 ⁻⁷ (1.48)		0.24		
PKP568N28AA2	PKP568N28BA2	1.5 (210)	500×10 ⁻⁷ (2.7)		0.37		

*See page 94 for details on the recommended drivers.

Speed – Torque Characteristics (Reference Values) fs: Max. Starting Frequency

PKP564N28AA2/ PKP564N28BA2

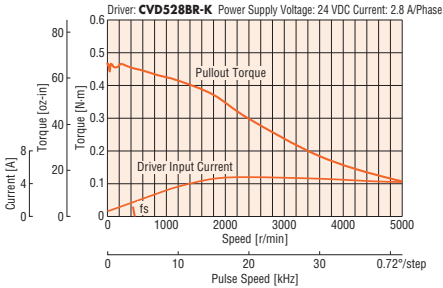

PKP566N28AA2/ PKP566N28BA2

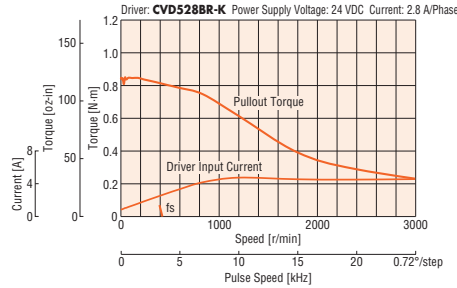

PKP568N28AA2/ PKP568N28BA2

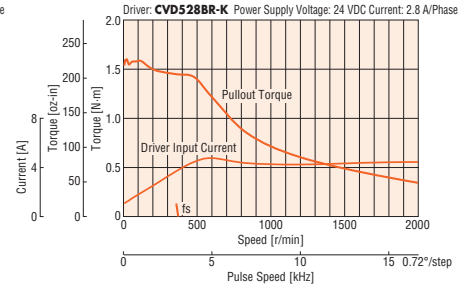

Note

- Data for the speed – torque characteristics is based on Oriental Motor's internal measurement conditions. If the conditions are changed, the characteristics may also change as a result.
- Depending on the driving conditions, a considerable amount of heat may be generated by the motor. Be sure to keep the motor case temperature at 100°C (212°F) max.
- Set the current of the driver so that it does not exceed the rated current of the motor.

Dimensions Unit: mm (in.)

Motor

2D & 3D CAD

Product Name	L1	L2	Mass kg (lb.)	2D CAD
PKP564N28AA2	39	—	0.43	B1359
PKP564N28BA2	(1.54)	62 (2.44)	(0.95)	
PKP566N28AA2	54	—	0.67	B1360
PKP566N28BA2	(2.13)	77 (3.03)	(1.47)	
PKP568N28AA2	76	—	1	B1361
PKP568N28BA2	(2.99)	99 (3.9)	(2.2)	

Applicable Connectors

Connector Housing: MDF97-5S-3.5C (HIROSE ELECTRIC CO.,LTD)
Contact: MDF97-22SC (HIROSE ELECTRIC CO.,LTD)
Crimp Tool : HT801/MDF97-22S (HIROSE ELECTRIC CO.,LTD)

Connection Cables (Sold separately)

Motor Connection Cables

Product Name	Length L m (ft.)
LC5N06E	0.6 (2)
LC5N10E	1 (3.3)

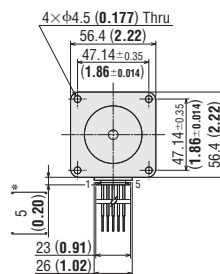
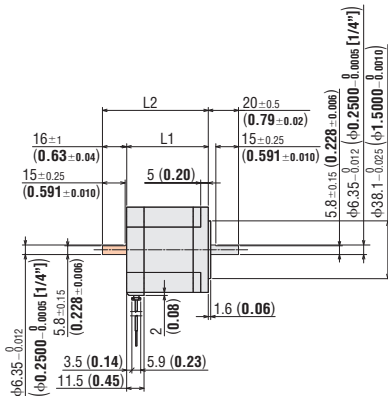
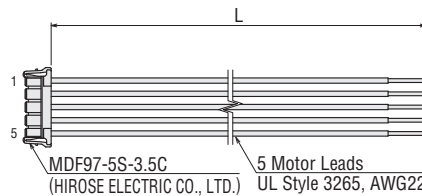

*With connection cable

- These dimensions are for double shaft motors.
For single shaft motors, ignore the [] areas.

Motor Pin Assignments

Motor Pin Assignments: Model A

- Refer to page 88 for inner wiring diagram of motor.

Standard Type with Encoder

Frame Size 56.4 mm (2.22 in.)

Specifications

Product Name	Maximum Holding Torque N·m (oz·in)	Rotor Inertia J: kg·m ² (oz·in ²)	Rated Current A/Phase	Winding Resistance Ω/Phase	Basic Step Angle	Recommended Driver Product Name*
PKP564N28A2-R2G	0.44 (62)	140×10 ⁻⁷ (0.77)	2.8	0.16	0.72°	CVD528BR-K
PKP564N28A2-R2G	0.81 (115)	270×10 ⁻⁷ (1.48)		0.24		
PKP564N28A2-R2G	1.5 (210)	500×10 ⁻⁷ (2.7)		0.37		

- The box in the product name indicates the encoder output circuit type L (line driver output). The voltage output type will have no " " in the product name.
- See page 88 for encoder specification.
- *See page 94 for details on the recommended drivers.

Speed – Torque Characteristics (Reference Values) fs: Max. Starting Frequency

PKP564N28A2-R2GL/PKP564N28A2-R2G

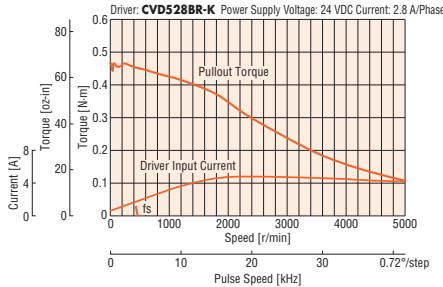

PKP566N28A2-R2GL/PKP566N28A2-R2G

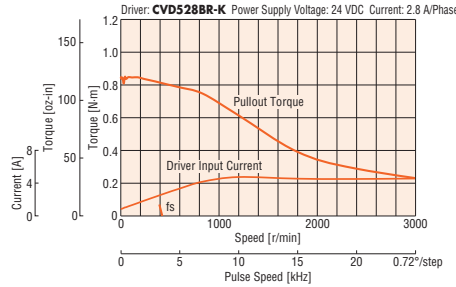

PKP568N28A2-R2GL/PKP568N28A2-R2G

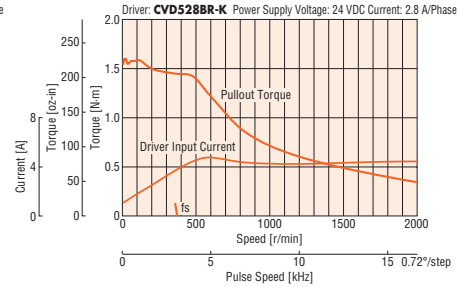

Note

- Data for the speed – torque characteristics is based on Oriental Motor's internal measurement conditions. If the conditions are changed, the characteristics may also change as a result.
- Depending on the driving conditions, a considerable amount of heat may be generated by the motor. Be sure to keep the motor case temperature at 85°C (185°F) max.
- Set the current of the driver so that it does not exceed the rated current of the motor.

Dimensions Unit: mm (in.)

Motor

2D & 3D CAD

Product Name	L	Mass kg (lb.)	2D CAD
PKP564N28A2-R2G	55.5 (2.19)	0.43 (0.95)	B1347
PKP566N28A2-R2G	70.5 (2.78)	0.67 (1.47)	B1348
PKP568N28A2-R2G	92.5 (3.64)	1 (2.2)	B1349

- The box in the product name indicates the encoder output circuit type L (line driver output). The voltage output type will have no " " in the product name.

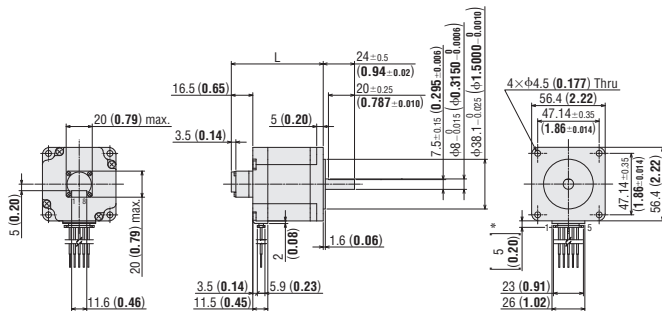

*With connection cable

Connection Cable (Sold separately)

Motor Connection Cable

Product Name	Length L m (ft.)
LC5N06E	0.6 (2)
LC5N10E	1 (3.3)

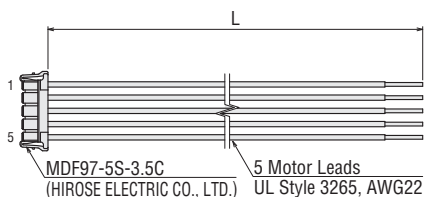

Motor Pin Assignments

Motor Pin Assignments: Model A

- Refer to page 88 for inner wiring diagram of motor.

Applicable Connector

	Motor (HIROSE ELECTRIC CO.,LTD.)	Encoder (Molex)
Connector Housing	MDF97-5S-3.5C	51021-0800
Contact	MDF97-22SC	50079-8100
Crimp Tool	HT801/MDF97-22S	57177-5000

Encoder Connection Cable

Encoder Output Circuit Type	Product Name	Length L [m (ft.)]
Line Driver Output Type	LCE08A-006	0.6 (2)
Voltage Output Type	LCE05A-006	

•LCE08A-006

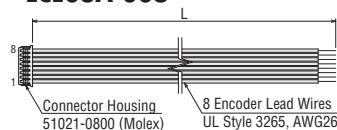

•LCE05A-006

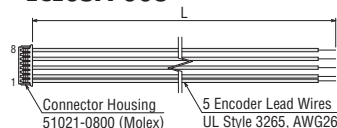

2-Phase
Motors
PKP

Features
Product
Line

Product
Number
Product Line

Standard
Type

High-
Resolution
Type

Flat Type

SH
Geared
Type

CS
Geared
Type

General
Specifications/
Inner Wiring
Diagram of Motor

5-Phase
Motors
PKP

Features
Product
Line

Product
Number
Product Line

Standard
Type

High-
Resolution
Type

TS
Geared
Type

General
Specifications/
Inner Wiring
Diagram of Motor

Driver for
2-Phase/
5-Phase Motors

Accessories

Standard Type

Frame Size 60 mm (2.36 in.)

Specifications

Product Name		Maximum Holding Torque N·m (oz·in)	Rotor Inertia J: kg·m ² (oz·in ²)	Rated Current A/Phase	Winding Resistance Ω/Phase	Basic Step Angle	Recommended Driver Product Name*
Single shaft	Double shaft						
PKP564FN24A2	PKP564FN24B2	0.66 (93)	160×10 ⁻⁷ (0.88)	2.4	0.28	0.72°	CVD524BR-K
PKP564FN38A2	PKP564FN38B2			3.8	0.12		CVD538BR-K
PKP566FN24A2	PKP566FN24B2			2.4	0.38		CVD524BR-K
PKP566FN38A2	PKP566FN38B2	3.8	0.16	CVD538BR-K			
PKP569FN24A2	PKP569FN24B2	2.1 (290)	540×10 ⁻⁷ (3.0)	2.4	0.64		CVD524BR-K
PKP569FN38A2	PKP569FN38B2			3.8	0.22		CVD538BR-K

*See page 94 for details on the recommended drivers.

Speed – Torque Characteristics (Reference Values) *f_s*: Max. Starting Frequency

PKP564FN24A2/ PKP564FN24B2

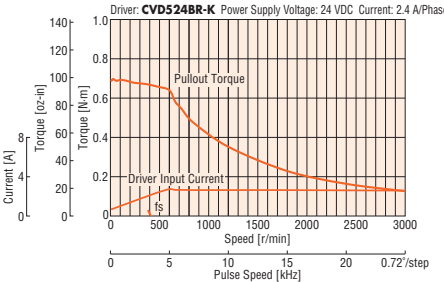

PKP566FN24A2/ PKP566FN24B2

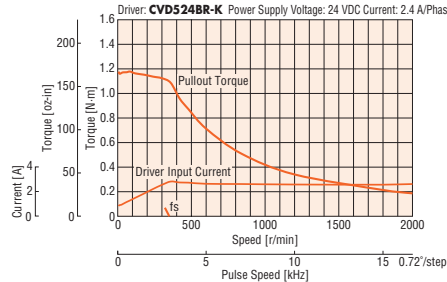

PKP569FN24A2/ PKP569FN24B2

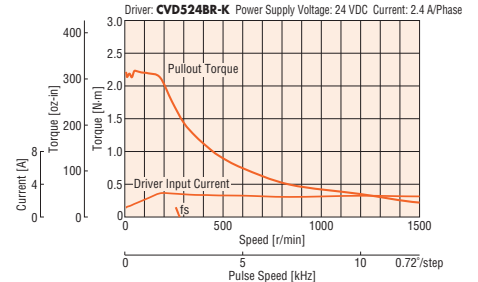

PKP564FN38A2/ PKP564FN38B2

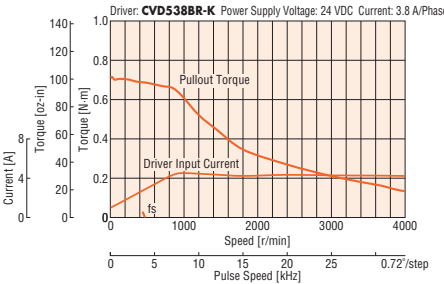

PKP566FN38A2/ PKP566FN38B2

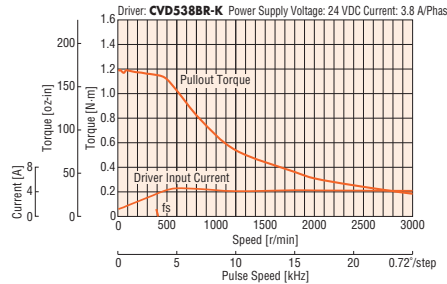

PKP569FN38A2/ PKP569FN38B2

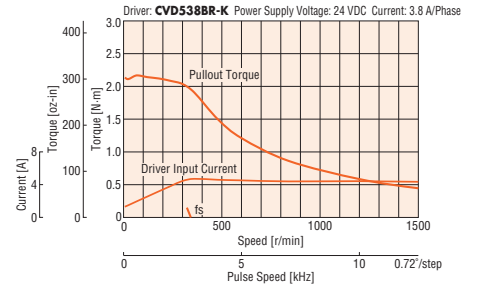

Note

- Data for the speed – torque characteristics is based on Oriental Motor's internal measurement conditions. If the conditions are changed, the characteristics may also change as a result.
- Depending on the driving conditions, a considerable amount of heat may be generated by the motor. Be sure to keep the motor case temperature at 100°C (212°F) max.
- Set the current of the driver so that it does not exceed the rated current of the motor.

Dimensions Unit: mm (in.)

Motor

2D & 3D CAD

Product Name	L1	L2	Mass kg (lb.)	2D CAD
PKP564FN24A2	44 (1.73)	—	0.56 (1.23)	B1252
PKP564FN24B2		65 (2.56)		
PKP564FN38A2		—		
PKP564FN38B2	56 (2.20)	65 (2.56)	0.79 (1.74)	B1253
PKP566FN24A2		—		
PKP566FN24B2		77 (3.03)		
PKP566FN38A2	84.5 (3.33)	77 (3.03)	1.3 (2.9)	B1254
PKP566FN38B2		—		
PKP569FN24A2		—		
PKP569FN24B2	84.5 (3.33)	105.5 (4.15)	1.3 (2.9)	B1254
PKP569FN38A2		—		
PKP569FN38B2		105.5 (4.15)		

Applicable Connectors

Connector Housing: MDF97-5S-3.5C (HIROSE ELECTRIC CO.,LTD)
 Contact: MDF97-22SC (HIROSE ELECTRIC CO.,LTD)
 Crimp Tool: HT801/MDF97-22S (HIROSE ELECTRIC CO.,LTD)

Connection Cables (Sold separately)

Motor Connection Cables

Product Name	Length L m (ft.)
LC5N06E	0.6 (2)
LC5N10E	1 (3.3)

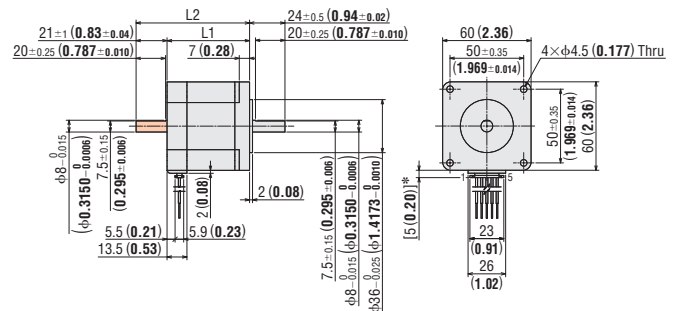
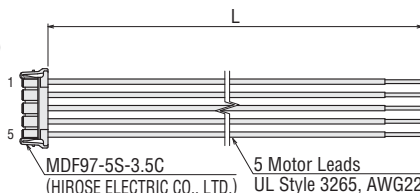

*With connection cable

● These dimensions are for double shaft motors.

For single shaft motors, ignore the shaft the areas.

Motor Pin Assignments

Motor Pin Assignments: Model A

● Refer to page 88 for inner wiring diagram of motor.

Standard Type with Encoder

Frame Size 60 mm (2.36 in.)

Specifications

Product Name	Maximum Holding Torque N·m (oz·in)	Rotor Inertia J: kg·m ² (oz·in ²)	Rated Current A/Phase	Winding Resistance Ω/Phase	Basic Step Angle	Recommended Driver Product Name*
PKP564FN24A2-R2G ■	0.66 (93)	160×10 ⁻⁷ (0.88)	2.4	0.28	0.72°	CVD524BR-K
PKP564FN38A2-R2G ■			3.8	0.12		CVD538BR-K
PKP566FN24A2-R2G ■	1.15 (163)	290×10 ⁻⁷ (1.59)	2.4	0.38		CVD524BR-K
PKP566FN38A2-R2G ■			3.8	0.16		CVD538BR-K
PKP569FN24A2-R2G ■	2.1 (290)	540×10 ⁻⁷ (3.0)	2.4	0.64		CVD524BR-K
PKP569FN38A2-R2G ■			3.8	0.22		CVD538BR-K

- The box ■ in the product name indicates the encoder output circuit type L (line driver output). The voltage output type will have no "■" in the product name.
- See page 88 for encoder specification.
- *See page 94 for details on the recommended drivers.

Speed – Torque Characteristics (Reference values) *f_s*: Max. Starting Frequency

PKP564FN24A2-R2GL/PKP564FN24A2-R2G Driver: **CVD524BR-K** Power Supply Voltage: 24 VDC Current: 2.4 A/Phase

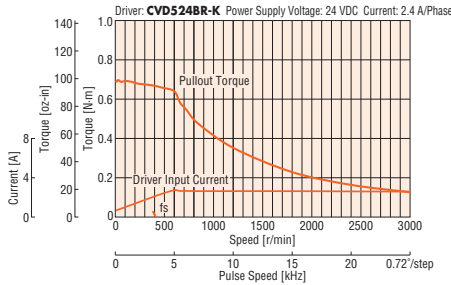

PKP566FN24A2-R2GL/PKP566FN24A2-R2G Driver: **CVD524BR-K** Power Supply Voltage: 24 VDC Current: 2.4 A/Phase

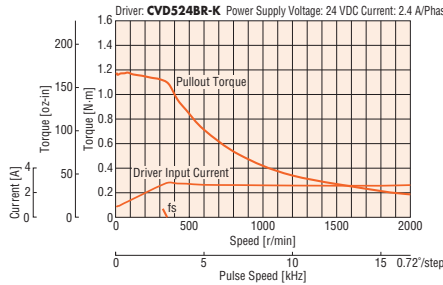

PKP569FN24A2-R2GL/PKP569FN24A2-R2G Driver: **CVD524BR-K** Power Supply Voltage: 24 VDC Current: 2.4 A/Phase

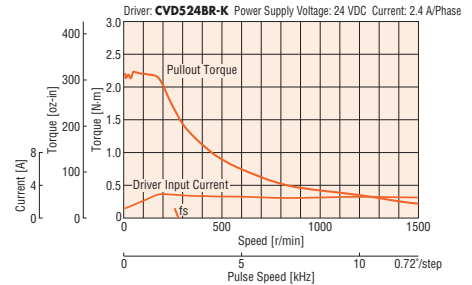

PKP564FN38A2-R2GL/PKP564FN38A2-R2G Driver: **CVD538BR-K** Power Supply Voltage: 24 VDC Current: 3.8 A/Phase

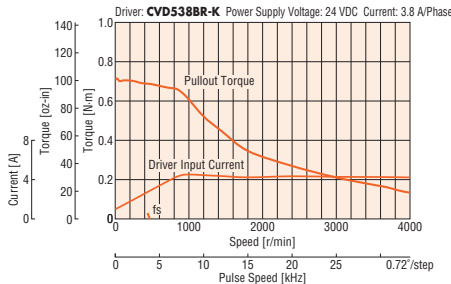

PKP566FN38A2-R2GL/PKP566FN38A2-R2G Driver: **CVD538BR-K** Power Supply Voltage: 24 VDC Current: 3.8 A/Phase

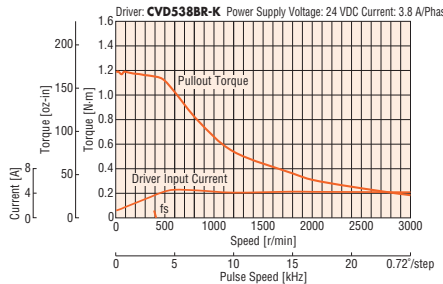

PKP569FN38A2-R2GL/PKP569FN38A2-R2G Driver: **CVD538BR-K** Power Supply Voltage: 24 VDC Current: 3.8 A/Phase

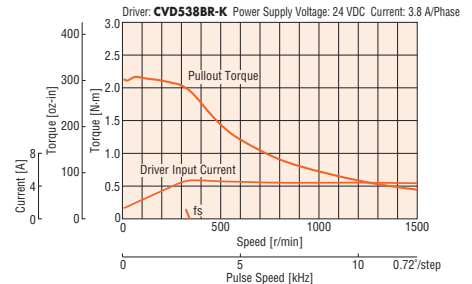

Note

- Data for the speed – torque characteristics is based on Oriental Motor's internal measurement conditions. If the conditions are changed, the characteristics may also change as a result.
- Depending on the driving conditions, a considerable amount of heat may be generated by the motor. Be sure to keep the motor case temperature at 85°C (185°F) max.
- Set the current of the driver so that it does not exceed the rated current of the motor.

Dimensions Unit: mm (in.)

Motor

2D & 3D CAD

Product Name	L	Mass kg	2D CAD
PKP564FN24A2-R2G ■	60.5	0.56 (1.23)	B1350
PKP564FN38A2-R2G ■	(72.38)		
PKP566FN24A2-R2G ■	72.5	0.79 (1.74)	B1351
PKP566FN38A2-R2G ■	(2.85)		
PKP569FN24A2-R2G ■	101	1.3 (2.9)	B1352
PKP569FN38A2-R2G ■	(3.98)		

- The box ■ in the product name indicates the encoder output circuit type L (line driver output). The voltage output type will have no "■" in the product name.

Applicable Connector

	Motor (HIROSE ELECTRIC CO.,LTD.)	Encoder (Molex)
Connector Housing	MDF97-5S-3.5C	51021-0800
Contact	MDF97-22SC	50079-8100
Crimp Tool	HT801/MDF97-22S	57177-5000

Connection Cable (Sold separately)

Motor Connection Cable

Product Name	Length L m (ft.)
LC5N06E	0.6 (2)
LC5N10E	1 (3.3)

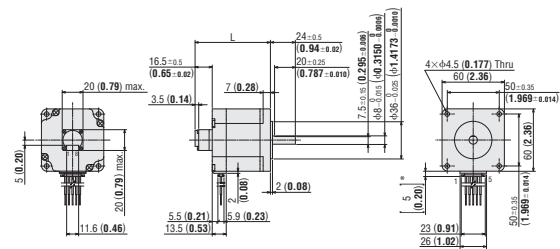
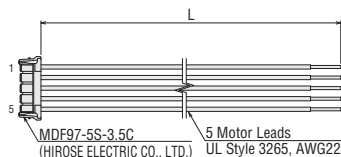

*With connection cable

Encoder Connection Cable

Encoder Output Circuit Type	Product Name	Length L [m (ft.)]
Line Driver Output Type	LCE08A-006	0.6 (2)
Voltage Output Type	LCE05A-006	

•LCE08A-006

•LCE05A-006

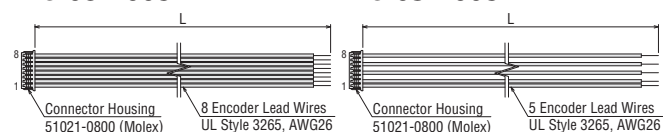

Motor Pin Assignments

Motor Pin Assignments: Model A

- Refer to page 88 for inner wiring diagram of motor.

2-Phase
Motors
PKP

Features
Product
Line

Product
Number
Product Line

Standard
Type

High-
Resolution
Type

Flat Type

SH
Geared
Type

CS
Geared
Type

General
Specifications/
Inner Wiring
Diagram of Motor

5-Phase
Motors
PKP

Features
Product
Line

Product
Number
Product Line

Standard
Type

High-
Resolution
Type

TS
Geared
Type

General
Specifications/
Inner Wiring
Diagram of Motor

Driver for
2-Phase/
5-Phase Motors

Accessories

High-Resolution Type

Frame Size 42 mm (1.65 in.)

20 mm
(0.79 in.)

28 mm
(1.10 in.)

35 mm
(1.38 in.)

42 mm
(1.65 in.)

50 mm
(1.97 in.)
51 mm
(2.01 in.)

56.4 mm
(2.22 in.)

60 mm
(2.36 in.)
61 mm
(2.40 in.)

85 mm
(3.35 in.)

Specifications

Product Name		Maximum Holding Torque N·m (oz-in)	Rotor Inertia J: kg·m ² (oz-in ²)	Rated Current A/Phase	Winding Resistance Ω/Phase	Basic Step Angle	Recommended Driver Product Name*
Single Shaft	Double Shaft						
PKP544MN18A	PKP544MN18B	0.26 (36)	60×10^{-7} (0.33)	1.8	0.51	0.36°	CVD518BR-K
PKP546MN18A	PKP546MN18B	0.44 (62)	121×10^{-7} (0.66)		0.66		

*See page 94 for details on the recommended drivers.

Speed – Torque Characteristics (Reference Values) fs: Max. Starting Frequency

PKP544MN18A/PKP544MN18B

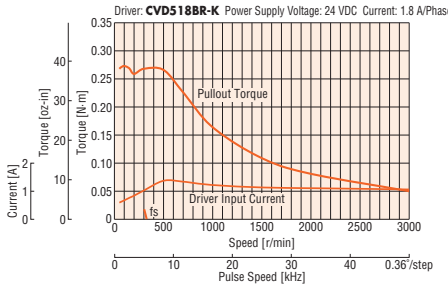

PKP546MN18A/PKP546MN18B

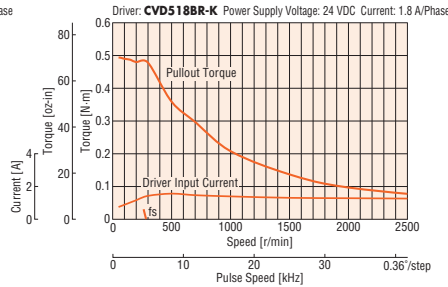

Note

- Data for the speed – torque characteristics is based on Oriental Motor's internal measurement conditions. If the conditions are changed, the characteristics may also change as a result.
- Depending on the driving conditions, a considerable amount of heat may be generated by the motor. Be sure to keep the motor case temperature at 100°C (212°F) max.
- Set the current of the driver so that it does not exceed the rated current of the motor.

Dimensions Unit: mm (in.)

Motor

2D & 3D CAD

Product Name	L1	L2	Mass kg (lb.)	2D CAD
PKP544MN18A	39	—	0.3	B1120
PKP544MN18B	(1.54)	54 (2.13)	(0.66)	
PKP546MN18A	59	—	0.5	B1121
PKP546MN18B	(2.32)	74 (2.91)	(1.1)	

Applicable Connectors

Connector Housing: 51103-0500 (Molex)
 Contact: 50351-8100 (Molex)
 Crimp Tool: 57295-5000 (Molex)

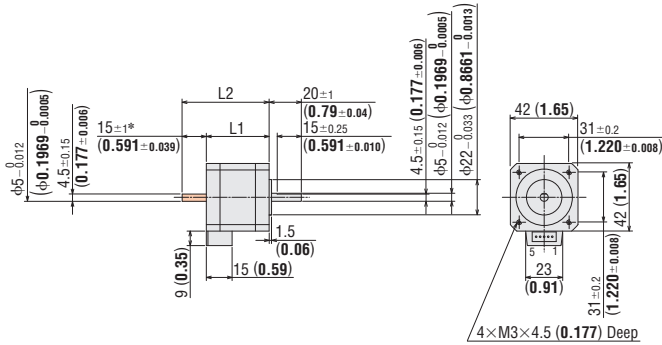

*The length of the shaft flat on the double shaft model is $15_{\pm 0.010}^{+0.006}$ (0.591 ± 0.010).

These dimensions are for double shaft motors.

For single shaft motors, ignore the shaft in the  areas.

Motor Pin Assignments

Motor Pin Assignments: Model B

Refer to page 88 for inner wiring diagram of motor.

Connection Cables (Sold separately)

Motor Connection Cables

Product Name	Length L m (ft.)
LC5N06B	0.6 (2)
LC5N10B	1 (3.3)

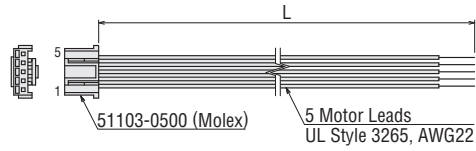

2-Phase
Motors
PKP

Features
Product
Line

Product
Number
Product Line

Standard
Type

High-
Resolution
Type

Flat Type

SH
Geared
Type

CS
Geared
Type

General
Specifications/
Inner Wiring
Diagram of Motor

5-Phase
Motors
PKP

Features
Product
Line

Product
Number
Product Line

Standard
Type

High-
Resolution
Type

TS
Geared
Type

General
Specifications/
Inner Wiring
Diagram of Motor

Driver for
2-Phase/
5-Phase Motors

Accessories

High-Resolution Type

Frame Size 60 mm (2.36 in.)

20 mm (0.79 in.)

28 mm (1.10 in.)

35 mm (1.38 in.)

42 mm (1.65 in.)

50 mm (1.97 in.)
51 mm (2.01 in.)

56.4 mm (2.22 in.)

60 mm (2.36 in.)
61 mm (2.40 in.)

85 mm (3.35 in.)

Specifications

Product Name		Maximum Holding Torque N·m (oz-in)	Rotor Inertia J: kg·m ² (oz-in ²)	Rated Current A/Phase	Winding Resistance Ω/Phase	Basic Step Angle	Recommended Driver Product Name*
Single Shaft	Double Shaft						
PKP564FMN24A	PKP564FMN24B	0.78 (110)	310×10^{-7} (1.70)	2.4	0.32	0.36°	CVD524BR-K
PKP566FMN24A	PKP566FMN24B	1.25 (177)	490×10^{-7} (2.7)		0.4		
PKP569FMN24A	PKP569FMN24B	2.3 (320)	970×10^{-7} (5.3)		0.66		

*See page 94 for details on the recommended drivers.

Speed – Torque Characteristics (Reference Values) fs: Max. Starting Frequency

PKP564FMN24A/PKP564FMN24B

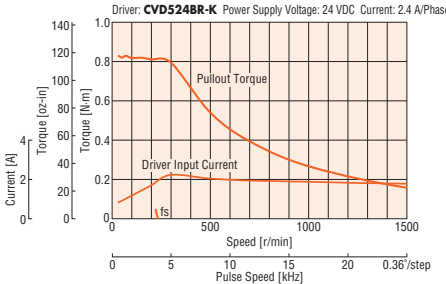

PKP566FMN24A/PKP566FMN24B

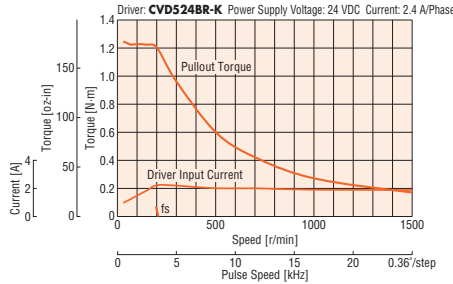

PKP569FMN24A/PKP569FMN24B

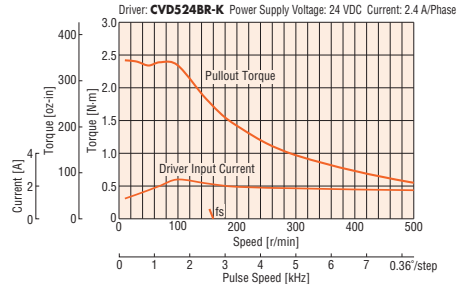

Note

- Data for the speed – torque characteristics is based on Oriental Motor's internal measurement conditions. If the conditions are changed, the characteristics may also change as a result.
- Depending on the driving conditions, a considerable amount of heat may be generated by the motor. Be sure to keep the motor case temperature at 100°C (212°F) max.
- Set the current of the driver so that it does not exceed the rated current of the motor.

Dimensions Unit: mm (in.)

Motor

2D & 3D CAD

Product Name	L1	L2	L3	φD	Mass kg (lb.)	2D CAD
PKP564FMN24A	46.5	—	7.5 ± 0.15 (0.295 ± 0.006)	8 ^{-0.15} ₀ (0.3150 ^{-0.006})	0.65 (1.43)	B1125
PKP564FMN24B	(1.83)	69.5 (2.74)				
PKP566FMN24A	56	—	9.5 ± 0.15 (0.374 ± 0.006)	10 ^{-0.15} ₀ (0.3937 ^{-0.006})	0.87 (1.92)	B1126
PKP566FMN24B	(2.20)	79 (3.11)				
PKP569FMN24A	87	—	110 (4.33)	—	—	B1127
PKP569FMN24B	(3.43)	110 (4.33)				

Connection Cables (Sold separately)

Motor Connection Cables

Product Name	Length L m (ft.)
LC5N06C	0.6 (2)
LC5N10C	1 (3.3)

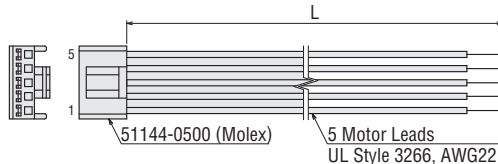

- Applicable Connectors
Connector Housing: 51144-0500 (Molex)
Contact: 50539-8100 (Molex)
Crimp Tool: 57189-5000 (Molex)

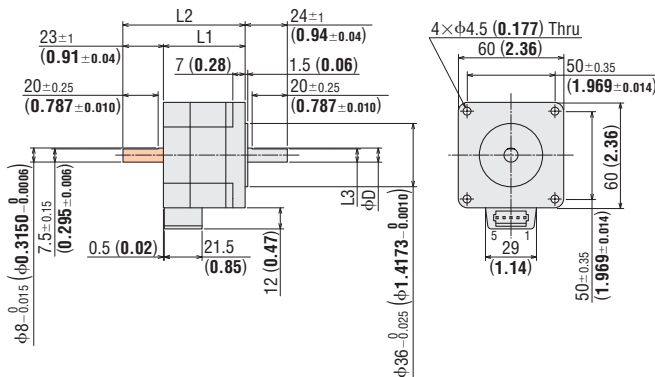

- These dimensions are for double shaft motors.
- For single shaft motors, ignore the shaft in the [shaded] areas.

Motor Pin Assignments

Motor Pin Assignments: Model B

- Refer to page 88 for inner wiring diagram of motor.

TS Geared Type

Frame Size 42 mm (1.65 in.)

2-Phase Motors
PKP

Specifications

Product Name	Maximum Holding Torque N·m (lb·in)	Rotor Inertia J: kg·m ² (oz·in ²)	Rated Current A/Phase	Winding Resistance Ω/Phase	Basic Step Angle	Gear Ratio	Permissible Torque N·m (lb·in)	Maximum Instantaneous Torque N·m (lb·in)	Speed Range r/min	Backlash arcmin	Recommended Driver Product Name*
PKP544N18 □ 2-TS3.6	0.65 (5.7)	55×10 ⁻⁷ (0.3)	1.8	0.48	0.2°	3.6	0.65 (5.7)	0.85 (7.5)	0 - 833	25 (0.42)	CVDS18BR-K
PKP544N18 □ 2-TS7.2	1.2 (10.6)				0.1°	7.2	1.2 (10.6)	1.6 (14.1)	0 - 416		
PKP544N18 □ 2-TS10	1.7 (15)				0.072°	10	1.7 (15)	2 (17.7)	0 - 300		
PKP543N18 □ 2-TS20	2 (17.7)	35×10 ⁻⁷ (0.191)	0.4	0.036°	20	2 (17.7)	3 (26)	0 - 150	15 (0.25)		
PKP543N18 □ 2-TS30	2.3 (20)				0.024°	30	2.3 (20)	3 (26)			

● The box □ in the product name indicates the shaft **A** (single shaft) or **B** (double shaft).

*See page 94 for details on the recommended drivers.

Speed – Torque Characteristics (Reference Values) fs: Max. Starting Frequency

PKP544N18A2-TS3.6/PKP544N18B2-TS3.6

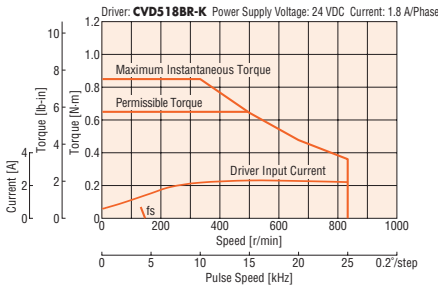

PKP544N18A2-TS7.2/PKP544N18B2-TS7.2

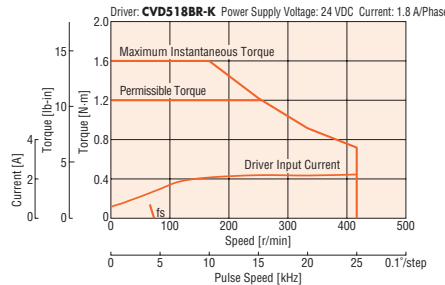

PKP544N18A2-TS10/PKP544N18B2-TS10

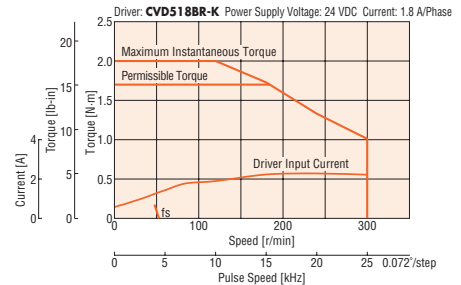

PKP543N18A2-TS20/PKP543N18B2-TS20

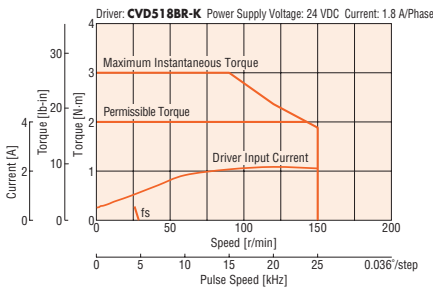

PKP543N18A2-TS30/PKP543N18B2-TS30

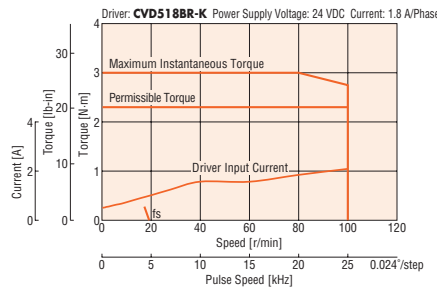

Note

- Data for the speed – torque characteristics is based on Oriental Motor's internal measurement conditions. If the conditions are changed, the characteristics may also change as a result.
- Depending on the driving conditions, a considerable amount of heat may be generated by the motor. Be sure to keep the motor case temperature at 100°C (212°F) max.
- Set the current of the driver so that it does not exceed the rated current of the motor.

Dimensions Unit: mm (in.)

● Motor

2D & 3D CAD

Product Name	Gear Ratio	L	Mass kg (lb.)	2D CAD
PKP544N18A2-TS □	3.6, 7.2, 10	70.5	0.41	B1362
PKP544N18B2-TS □		(2.78)	(0.9)	
PKP543N18A2-TS □	20, 30	64.5	0.36	B1363
PKP543N18B2-TS □		(2.59)	(0.79)	

● The box □ in the product name indicates a number representing the gear ratio.

● Applicable Connectors

Connector Housing: MDF97-5S-3.5C (HIROSE ELECTRIC CO.,LTD)
Contact: MDF97-22SC (HIROSE ELECTRIC CO.,LTD)
Crimp Tool: HT801/MDF97-22S (HIROSE ELECTRIC CO.,LTD)

● Connection Cables (Sold separately)

◇ Motor Connection Cables

Product Name	Length L m (ft.)
LC5N06E	0.6 (2)
LC5N10E	1 (3.3)

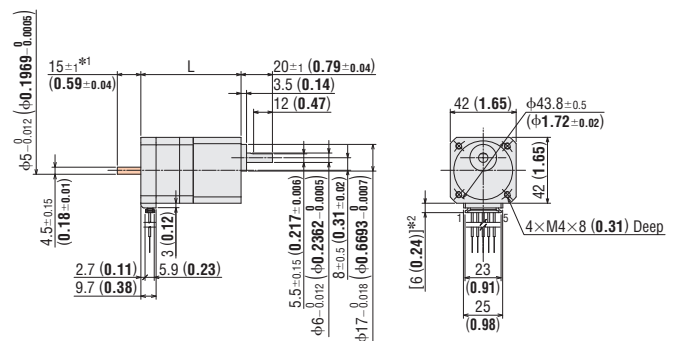
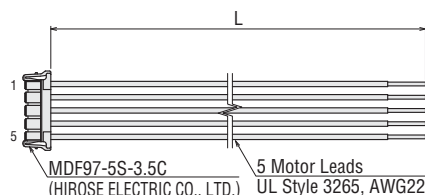

*1 The length of the shaft flat on the double shaft model is 15±0.25 (0.591±0.010).

*2 With connection cable

● These dimensions are for double shaft motors.

For single shaft motors, ignore the shaded areas.

Motor Pin Assignments

Motor Pin Assignments: Model A

● Refer to page 88 for inner wiring diagram of motor.

Features
Product Line

Product
Number
Product Line

Standard
Type

High-Resolution
Type

Flat Type

SH
Geared
Type

CS
Geared
Type

General
Specifications/
Inner Wiring
Diagram of Motor

5-Phase
Motors
PKP

Features
Product Line

Product
Number
Product Line

Standard
Type

High-Resolution
Type

TS
Geared
Type

General
Specifications/
Inner Wiring
Diagram of Motor

Driver for
2-Phase/
5-Phase Motors

Accessories

TS Geared Type

Frame Size 60 mm (2.36 in.)

- 20 mm (0.79 in.)
- 28 mm (1.10 in.)
- 35 mm (1.38 in.)
- 42 mm (1.65 in.)
- 50 mm (1.97 in.)
- 51 mm (2.01 in.)
- 56.4 mm (2.22 in.)
- 60 mm (2.36 in.)
- 61 mm (2.40 in.)
- 85 mm (3.35 in.)

Specifications

Product Name	Maximum Holding Torque N·m (lb-in)	Rotor Inertia J: kg·m ² (oz-in ²)	Rated Current A/Phase	Winding Resistance Ω/Phase	Basic Step Angle	Gear Ratio	Permissible Torque N·m (lb-in)	Maximum Instantaneous Torque N·m (lb-in)	Speed Range r/min	Backlash arcmin	Recommended Driver Product Name*
PKP566N28□2-TS3.6	1.8 (15.9)	270 × 10 ⁻⁷ (1.48)	2.8	0.24	0.2°	3.6	1.8 (15.9)	2.5 (22)	0 - 833	35 (0.59°)	CVDS28BR-K
PKP566N28□2-TS7.2	3 (26)				0.1°	7.2	3 (26)	4.5 (39)	0 - 416		
PKP566N28□2-TS10	4 (35)				0.072°	10	4 (35)	6 (53)	0 - 300		
PKP564N28□2-TS20	5 (44)	140 × 10 ⁻⁷ (0.77)	0.16	0.036°	20	5 (44)	8 (70)	0 - 150			
PKP564N28□2-TS30	6 (53)				30	6 (53)	10 (88)	0 - 100			

● The box □ in the product name indicates the shaft **A** (single shaft) or **B** (double shaft).

*See page 94 for details on the recommended drivers.

Speed – Torque Characteristics (Reference Values) *fs*: Max. Starting Frequency

PKP566N28A2-TS3.6/PKP566N28B2-TS3.6

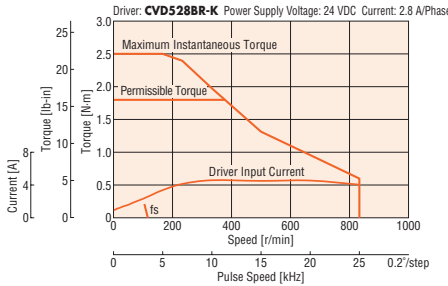

PKP566N28A2-TS7.2/PKP566N28B2-TS7.2

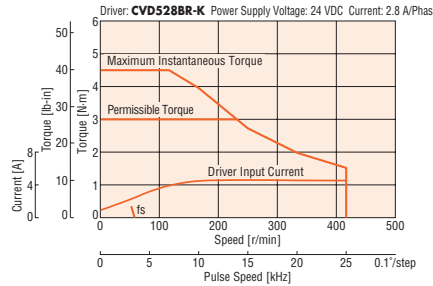

PKP566N28A2-TS10/PKP566N28B2-TS10

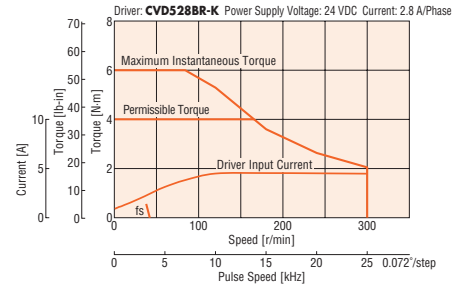

PKP564N28A2-TS20/PKP564N28B2-TS20

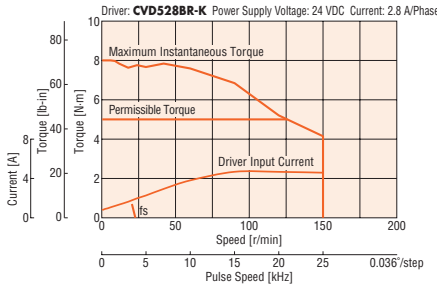

PKP564N28A2-TS30/PKP564N28B2-TS30

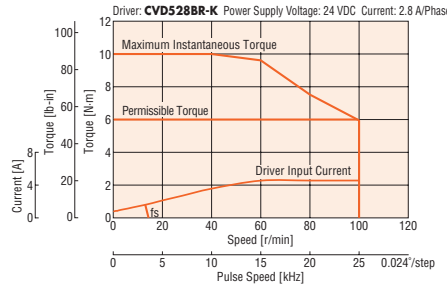

Note

- Data for the speed – torque characteristics is based on Oriental Motor's internal measurement conditions. If the conditions are changed, the characteristics may also change as a result.
- Depending on the driving conditions, a considerable amount of heat may be generated by the motor. Be sure to keep the motor case temperature at 100°C (212°F) max.
- Set the current of the driver so that it does not exceed the rated current of the motor.

Dimensions Unit: mm (in.)

Motor

2D & 3D CAD

Product Name	Gear Ratio	L	Mass kg (lb.)	2D CAD
PKP566N28A2-TS□	3.6, 7.2, 10	98	0.99	B1364
PKP566N28B2-TS□		(3.86)	(2.2)	
PKP564N28A2-TS□	20, 30	83	0.78	B1365
PKP564N28B2-TS□		(3.27)	(1.72)	

● The box □ in the product name indicates a number representing the gear ratio.

● Mounting Screw: M4×60 (2.36 in.) P0.7 (4 screws included)

● Applicable Connectors

Connector Housing: MDF97-5S-3.5C (HIROSE ELECTRIC CO.,LTD)

Contact: MDF97-22SC (HIROSE ELECTRIC CO.,LTD)

Crimp Tool: HT801/MDF97-22S (HIROSE ELECTRIC CO.,LTD)

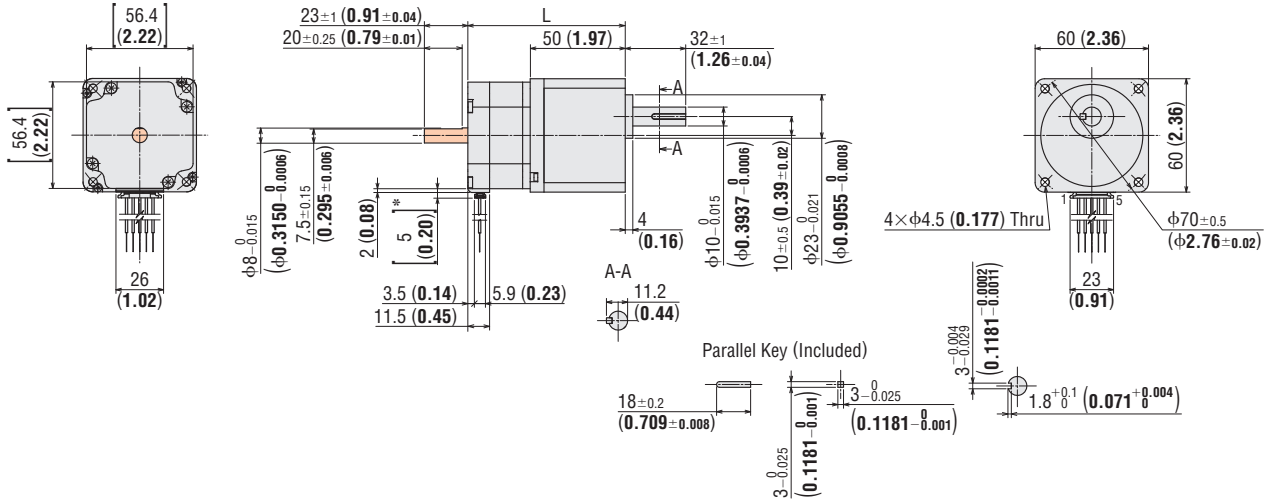

*With connection cable

● These dimensions are for double shaft motors.

For single shaft motors, ignore the shaded areas.

Connection Cables (Sold separately)

Motor Connection Cable

Product Name	Length L m (ft.)
LC5N06E	0.6 (2)
LC5N10E	1 (3.3)

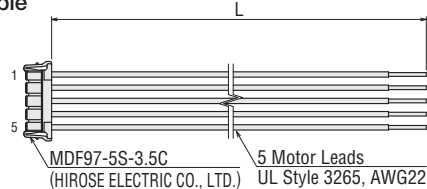

Motor Pin Assignments

Motor Pin Assignments: Model A

● Refer to page 88 for inner wiring diagram of motor.

2-Phase
Motors
PKP

Features
Product
Line

Product
Number
Product Line

Standard
Type

High-
Resolution
Type

Flat Type

SH
Geared
Type

CS
Geared
Type

General
Specifications/
Inner Wiring
Diagram of Motor

5-Phase
Motors
PKP

Features
Product
Line

Product
Number
Product Line

Standard
Type

High-
Resolution
Type

TS
Geared
Type

General
Specifications/
Inner Wiring
Diagram of Motor

Driver for
2-Phase/
5-Phase Motors

Accessories

Motor Frame Size

20 mm (0.79 in.)

28 mm (1.10 in.)

35 mm (1.38 in.)

42 mm (1.65 in.)

50 mm (1.97 in.)
51 mm (2.01 in.)

56.4 mm (2.22 in.)

60 mm (2.36 in.)
61 mm (2.40 in.)

85 mm (3.35 in.)

General Specifications

Specification		Motor
Thermal Class		130 (B)
Insulation Resistance		100 MΩ or more when 500 VDC megger is applied between the windings and the case under normal ambient temperature and humidity.
Dielectric Strength		No abnormalities are observed, even when applying voltage between the windings and the case for 1 minute under normal ambient temperature and humidity with the following conditions. • PK513 , PKP52 , and PKP54 : 0.5 kVAC, 50/60 Hz • PKP56 : 1.0 kVAC, 50/60 Hz • PKP56 , FMN , and PK59 : 1.5 kVAC, 50/60 Hz
Operating Environment	Ambient Temperature	-10~+50°C (+14~+122°F) (Non-freezing)
	Ambient Humidity	85% or less (Non-Condensing)
	Surrounding Atmosphere	No corrosive gas or dust. No water or oil.
Temperature Rise		Winding temperature rise 80°C (144°F) max. (Based on Oriental Motor's internal measurement conditions)
Stop Position Accuracy*1		Standard Type: ±3 arcmin (±0.05°) [PK513 : ±10 arcmin (±0.17°)] High-Resolution Type: ±2 arcmin (±0.034°)
Shaft Runout		0.05 mm (0.002 in.) T.I.R.*4
Radial Play*2		0.025 mm (0.001 in.) Max. [Load 5 N (1.12lb.)]
Axial Play*3		0.075 mm (0.003 in.) Max. [Load 10 N (2.2 lb.)] PK513 : Load 1 N (0.225 lb.), PKP52 : Load 2.5 N (0.566 lb.)]
Concentricity of Installing Pilot to the Shaft		0.075 mm (0.003 in.) T.I.R.*4
Perpendicularity of Installation Surface to the Shaft		0.075 mm (0.003 in.) T.I.R.*4

*1 This value is for full step under no load. (The value changes with the size of the load.)

*2 Radial Play: Displacement in shaft position in the radial direction when a 5 N (1.12 lb.) load is applied in the vertical direction to the tip of the motor shaft.

*3 Axial Play: Displacement in shaft position in the axial direction when a 10 N (2.2 lb.) [**PK513** is 1 N (0.225 lb.), **PKP52** is 2.5 N (0.566 lb.)] load is applied to the motor shaft in the axial direction.

*4 T.I.R. (Total Indicator Reading): The total dial gauge reading when the measurement section is rotated one revolution centered on the reference axis center.

Note

● Do not measure the insulation resistance or perform a dielectric strength test while the motor and driver are connected.
And, do not conduct these tests on the motor encoder section.

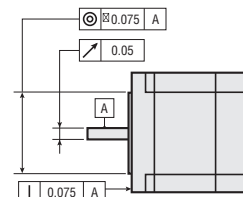

Encoder Specifications

Product Name	R2GL	R2G
Resolution	500P/R	500P/R
Output Circuit Type	Line Driver Output	Voltage Output
Output Mode	Incremental	
Output Signal	A Phase, B Phase, and Z Phase (3ch)	
Power Supply Voltage	5 VDC ±10%	
Current	30 mA max.	45 mA max.

Motor Pin Assignments

Model of Motor	Pin Assignment/Lead Wire Color													
Model A		<table border="1"> <thead> <tr> <th>Pin No.</th> <th>Lead Wire Color*</th> </tr> </thead> <tbody> <tr><td>5</td><td>Blue</td></tr> <tr><td>4</td><td>Red</td></tr> <tr><td>3</td><td>Orange</td></tr> <tr><td>2</td><td>Green</td></tr> <tr><td>1</td><td>Black</td></tr> </tbody> </table>	Pin No.	Lead Wire Color*	5	Blue	4	Red	3	Orange	2	Green	1	Black
		Pin No.	Lead Wire Color*											
5	Blue													
4	Red													
3	Orange													
2	Green													
1	Black													
*The colors of lead wires show arrangement of colors of the connection cable sold separately.														
Model B		<table border="1"> <thead> <tr> <th>Pin No.</th> <th>Lead Wire Color*</th> </tr> </thead> <tbody> <tr><td>1</td><td>Blue</td></tr> <tr><td>2</td><td>Red</td></tr> <tr><td>3</td><td>Orange</td></tr> <tr><td>4</td><td>Green</td></tr> <tr><td>5</td><td>Black</td></tr> </tbody> </table>	Pin No.	Lead Wire Color*	1	Blue	2	Red	3	Orange	4	Green	5	Black
		Pin No.	Lead Wire Color*											
1	Blue													
2	Red													
3	Orange													
4	Green													
5	Black													
*The colors of lead wires show arrangement of colors of the connection cable sold separately.														
Model C		<table border="1"> <thead> <tr> <th>Lead Wire Color</th> </tr> </thead> <tbody> <tr><td>Blue</td></tr> <tr><td>Red</td></tr> <tr><td>Orange</td></tr> <tr><td>Green</td></tr> <tr><td>Black</td></tr> </tbody> </table>	Lead Wire Color	Blue	Red	Orange	Green	Black						
Lead Wire Color														
Blue														
Red														
Orange														
Green														
Black														

Rotation Direction

This indicates the rotation direction as viewed from the output shaft side of the motor. The rotation direction of the output gear shaft relative to the standard type motor output shaft varies depending on the gear type and gear ratio. Please check the following table.

Geared Type		Gear Ratio	Rotation Direction of the Gear Output Shaft
TS Geared	Frame Size 42 mm (1.65 in.), 60 mm (2.36 in.)	3.6, 7.2, 10	Same as the motor output shaft
		20, 30	Opposite as the motor output shaft

Standard Type Motor

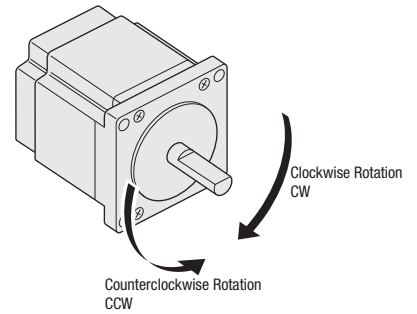

Permissible Radial Load and Permissible Axial Load

Unit: N (lb.)

Type	Motor Frame Size mm [in.]	Product Name	Gear Ratio	Permissible Radial Load					Permissible Axial Load
				Distance from the Tip of Motor Output Shaft mm [in.]					
				0	5	10	15	20	
Standard	20 mm [0.79]	PK513	—	12 (2.7)	15 (3.3)	—	—	—	3 (0.67)
	28 mm [1.10]	PKP523, PKP525	—	25 (5.6)	34 (7.6)	52 (11.7)	—	—	5 (1.12)
	42 mm [1.65]	PKP543, PKP544, PKP545, PKP546	—	35 (7.8)	44 (9.9)	58 (13)	85 (19.1)	—	15 (3.3)
	56.4 mm [2.22]	PKP564, PKP566, PKP568	—	90 (20)	100 (22)	130 (29)	180 (40)	270 (60)	30 (6.7)
High-Resolution	60 mm [2.36]	PKP564, PKP566, PKP569	—	90 (20)	100 (22)	130 (29)	180 (40)	270 (60)	30 (6.7)
	42 mm [1.65]	PKP544, PKP546	—	20 (4.5)	25 (5.6)	34 (7.6)	52 (11.7)	—	10 (2.2)
TS Geared	60 mm [2.36]	PKP564, PKP566, PKP569	—	90 (20)	100 (22)	130 (29)	180 (40)	270 (60)	20 (4.5)
	42 mm [1.65]	PKP544	3.6, 7.2, 10	20 (4.5)	30 (6.7)	40 (9)	50 (11.2)	—	15 (3.3)
PKP543		20, 30	40 (9)	50 (11.2)	60 (13.5)	70 (15.7)	—		
PKP566		3.6, 7.2, 10	120 (27)	135 (30)	150 (33)	165 (37)	180 (40)	40 (9)	
PKP564	20, 30	170 (38)	185 (41)	200 (45)	215 (48)	230 (51)			

Radial Load and Axial Load

Distance from Shaft End [mm (in.)]

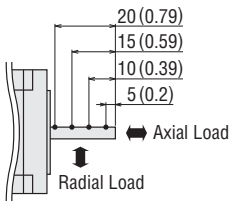

2-Phase Motors
PKP

Features Product Line

Product Number Product Line

Standard Type

High-Resolution Type

Flat Type

SH Geared Type

CS Geared Type

General Specifications/
Inner Wiring Diagram of Motor

5-Phase Motors
PKP

Features Product Line

Product Number Product Line

Standard Type

High-Resolution Type

TS Geared Type

General Specifications/
Inner Wiring Diagram of Motor

Driver for 2-Phase/
5-Phase Motors

Accessories

Bipolar Driver for 2-Phase Stepper Motors Driver for 5-Phase Stepper Motors

2-Phase
Bipolar
5-Phase

Cables

● For detailed information about regulations and standards, please refer to the Oriental Motor website.

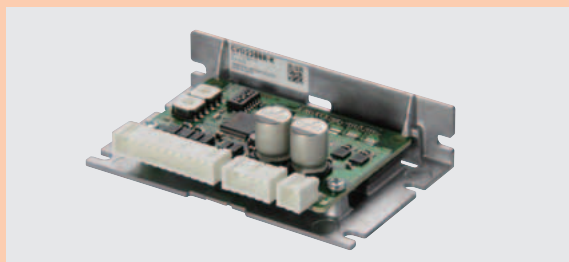

This is a DC power supply input driver for stepper motors. A bipolar driver for 2-phase stepper motors and a driver for 5-phase stepper motors are available. Using this microstepping driver reduces vibration and noise.



See Full Product Details Online
www.orientalmotor.com

● Manual

● Specifications

● Dimensions

● CAD

● Characteristics

● Connection and Operation

Features and Types

● Bipolar Driver for 2-Phase Stepper Motors Driver for 5-Phase Stepper Motors

Driver Type	External View	Introduction	Driver Installation Direction
<ul style="list-style-type: none"> ● Bipolar Driver for 2-Phase Stepper Motors ● Driver for 5-Phase Stepper Motors <p>52.5 mm (2.07 in.)</p> <p>24.5 mm (0.96 in.)</p> <p>85 mm (3.35 in.)</p> <p>• Mass 20 g (0.71 oz.)~70 g (2.47 oz.) (The value differs according to the driver type.)</p> <p>● The driver cannot be shared by both a 2-Phase stepper motors and 5-Phase stepper motors. Each must use its respective dedicated driver.</p>	<p>The connector points outward.</p>	<ul style="list-style-type: none"> • Compact and lightweight driver with full-time microstepping. • Using the smooth drive function reduces the vibration and noise more than conventional products. 	<ul style="list-style-type: none"> • Horizontal installation • Vertical installation
<p>Without Installation Plate</p>	<p>The connector points upward.</p>	<ul style="list-style-type: none"> • The driver is equipped with a protective function that enables you to find driver errors early. • Run current can be easily set with the digital switch. 	

● Additional Product Line

◇ Bipolar Driver S Type for 2-Phase/5-Phase Stepper Motors



This is a compact board mounting type driver. See website for details.

◇ **NEW** RS-485 Communications Type

See website for details.



◇ CVK Series **SC** Type Driver

This driver allows the stepper motors to operate like a speed control motor.

It can be operated easily by using the forward and reverse inputs only.

- No Pulse Generator Required
- Available for Setting in Two Speeds
- Compact and High-Torque
- Enhanced Repeatability of the Stop Position
- Possible to Hold the Load at Standstill

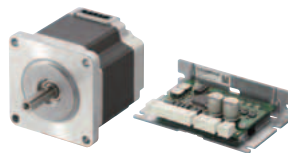

See website for details.

Low Vibration with Full-Time Microstepping

Low vibration and noise reduction have been achieved across all speed ranges by significantly improving the vibration level with the use of a fully digital-controlled full-time microstep driver. The **CVD** 5 phase driver and motor has further improved vibration characteristic.

●Reduced Step Vibration

The new smooth drive control with higher current control increases the basic step angle to a maximum resolution of 2048. As a result, a reduction in step vibration in the low-speed range is achieved.

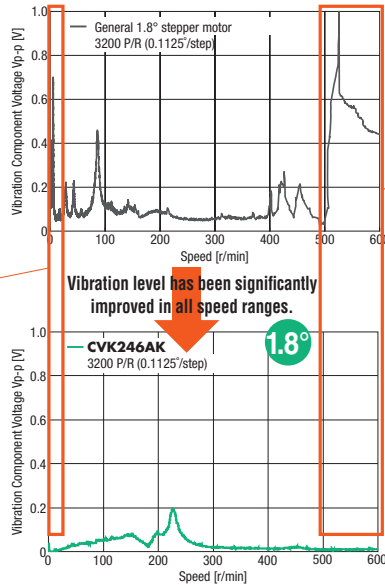

●Vibration Suppression Control

Common vibration that occurs in the mid-speed range has been suppressed. This enables more stable torque characteristics.

CVD/PKP

Vibration characteristics for 0.72°/0.36° stepper motors have been further improved.

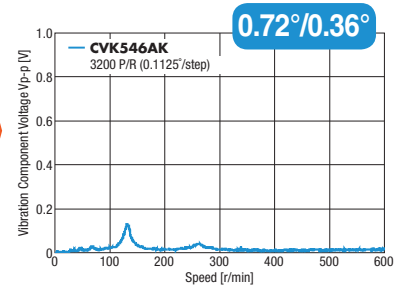

For High Positioning Accuracy Use a 0.72°/0.36° Stepper Motor

In general, stopping accuracy tends to be lower during microstep operation* than full step operation and this effect is more noticeable in a 1.8° motor. In this situation, using a **CVD** 5 phase driver and motor enables a higher positioning accuracy.

*Max. resolution 125000 P/R

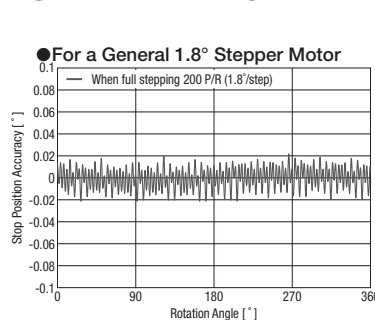

0.72°/0.36°

●For a **CVD** driver, 0.72°/0.36° Stepper Motor

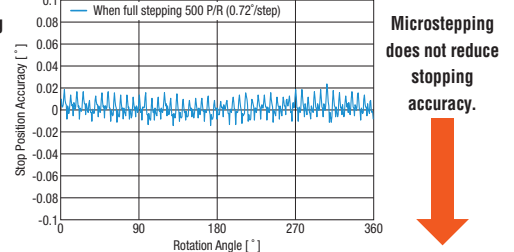

●Stopping Accuracy
 0.72° stepper motor standard type ±0.05° (±3 min)
 0.36° stepper motor high-resolution type ±0.034° (±2 min)

CVD/PKP

High positioning accuracy is now possible with 0.72°/0.36° stepper motors

There's a Wide Choice with 1.8° and 0.72°/0.36° Stepper Motors

The size, installation and I/O connectors for the **CVD** drivers and 1.8° or 0.72°/0.36° motors are the same. Because of this, it is easy to evaluate and select the proper package for the requirement.

*The driver for a 1.8° stepper motor and the driver for a 0.72°/0.36° stepper motor are not interchangeable. Each motor type has a dedicated driver. Use the Step Angle Setting Switch to set the proper resolution without changing your controller's pulse output.

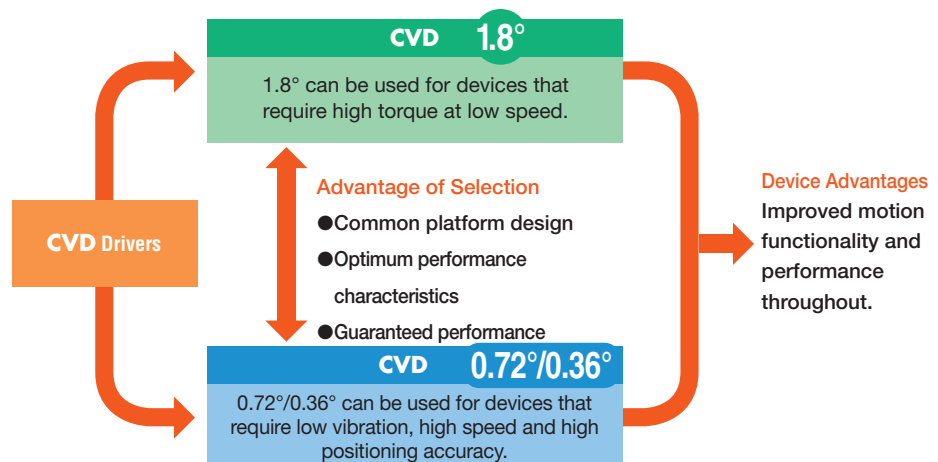

Bipolar Driver for 2-Phase Stepper Motors Driver for 5-Phase Stepper Motors

Product Number

CVD 2 23 F B R - K

① ② ③ ④ ⑤ ⑥ ⑦

①	Driver Type
②	2 : 2-Phase 5 : 5-Phase
③	Rated Current
④	Driver Identification
⑤	Driver Shape B : With Installation Plate Blank: Without Installation Plate
⑥	Connector Shape R : Right Angle
⑦	Power Supply Input K : DC Power Supply

Product Line

We have prepared a connection cable set (sold separately) consisting of motor, power supply, and I/O signal cables. The connectors are already crimped, which makes them easy to wire without crimp tools.

● Bipolar Driver for 2-Phase Stepper Motors

◇ Right Angle Type with Installation Plate

Product Name	List Price
CVD205BR-K	\$135.00
CVD206BR-K	
CVD215BR-K	
CVD223BR-K	
CVD223FBR-K	
CVD228BR-K	
CVD242BR-K	\$150.00
CVD245BR-K	

◇ Without Installation Plate

Product Name	List Price
CVD205-K	\$130.00
CVD206-K	
CVD215-K	
CVD223-K	
CVD223F-K	
CVD228-K	

● Driver for 5-Phase Stepper Motors

◇ Right Angle Type with Installation Plate

Product Name	List Price
CVD503BR-K	\$145.00
CVD507BR-K	
CVD512BR-K	
CVD514BR-K	
CVD518BR-K	
CVD524BR-K	
CVD528BR-K	\$160.00
CVD538BR-K	

◇ Without Installation Plate

Product Name	List Price
CVD503-K	\$140.00
CVD507-K	
CVD512-K	
CVD514-K	
CVD518-K	
CVD524-K	

Included

Type	Connector for Driver Connection	Operating Manual
Common to All Types	CN1 Connector (1 pc.), CN2 Connector (1 pc.), CN3 Connector (1 pc.)	1 Copy

Specifications

● Bipolar Driver for 2-Phase Stepper Motors



Product Name	CVD205 □□-K	CVD206 □□-K	CVD215 □□-K	CVD223 □□-K CVD223F □□-K	CVD228 □□-K	CVD242B □-K	CVD245B □-K
Driving Method	Microstep Drive, Bipolar, Constant Current Drive Method						
Motor Driving Current (Factory Setting)	0.5 A/Phase	0.6 A/Phase	1.5 A/Phase	2.3 A/Phase	2.8 A/Phase	4.2 A/Phase	4.5 A/Phase
Power Supply Voltage	24 VDC±10%						
Input Current	A 0.5	0.5	1.9	2.0	3.0	3.6	3.9
Max. Input Pulse Frequency	Line driver output by programmable controller: 1 MHz (When the pulse duty is 50%) Open-collector output by programmable controller: 250 kHz (When the pulse duty is 50%) Negative Logic Pulse Input						
Operating Environment (In operation)	Ambient Temperature	0 to +50°C (+32 to +122°F) (Non-freezing)					
	Ambient Humidity	85% or less (Non-condensing)					
	Surrounding Atmosphere	No corrosive gas or dust. No water or oil.					

● For the right angle type with an installation plate, the box □ in the product name indicates the driver shape **B** (with installation plate), the box □ indicates the connector shape **R** (right angle).

● Driver for 5-Phase Stepper Motors



Product Name	CVD503 □□-K	CVD507 □□-K	CVD512 □□-K	CVD514 □□-K	CVD518 □□-K	CVD524 □□-K	CVD528B □-K	CVD538B □-K
Driving Method	Microstep Drive, Bipolar, Constant Current Drive Method							
Motor Driving Current (Factory Setting)	0.35 A/Phase	0.75 A/Phase	1.2 A/Phase	1.4 A/Phase	1.8 A/Phase	2.4 A/Phase	2.8 A/Phase	3.8 A/Phase
Power Supply Voltage	24 VDC±10%							
Input Current	A 0.6	1.4	1.7	1.8	2.8	3.0	4.8	4.8
Max. Input Pulse Frequency	Line driver output by programmable controller: 1 MHz (When the pulse duty is 50%) Open-collector output by programmable controller: 250 kHz (When the pulse duty is 50%) Negative Logic Pulse Input							
Operating Environment (In operation)	Ambient Temperature	0 to +50°C (+32 to +122°F) (Non-freezing)						
	Ambient Humidity	85% or less (Non-condensing)						
	Surrounding Atmosphere	No corrosive gas or dust. No water or oil.						

● For the right angle type with an installation plate, the box □ in the product name indicates the driver shape **B** (with installation plate), the box □ indicates the connector shape **R** (right angle).

Dimensions Unit = mm (in.)

Right Angle Type with Installation Plate

2D & 3D CAD

Product Name	Mass kg (oz)	2D CAD
CVD205BR-K	0.06 (2.12)	B1210
CVD206BR-K		
CVD215BR-K		
CVD223BR-K		
CVD223FBR-K		
CVD228BR-K		
CVD503BR-K		
CVD507BR-K		
CVD512BR-K		
CVD514BR-K		
CVD518BR-K		
CVD524BR-K		

● Included Items

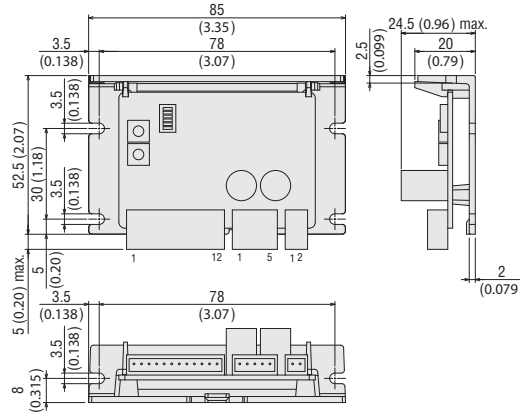

2D & 3D CAD

Product Name	Mass kg (oz)	2D CAD
CVD242BR-K	0.07 (2.47)	B1211
CVD245BR-K		
CVD528BR-K		
CVD538BR-K		

● Included Items

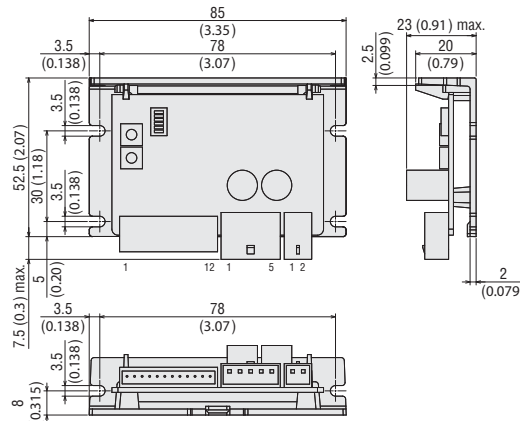

● Motor, power supply, and I/O signal cables are available as connection cable sets (sold separately). Refer to page 71 for details.

Without Installation Plate

2D & 3D CAD

Product Name	Mass kg (oz)	2D CAD
CVD205-K	0.02 (0.71)	B1128
CVD206-K		
CVD215-K		
CVD223-K		
CVD223F-K		
CVD228-K		
CVD503-K		
CVD507-K		
CVD512-K		
CVD514-K		
CVD518-K		
CVD524-K		

● Included Items

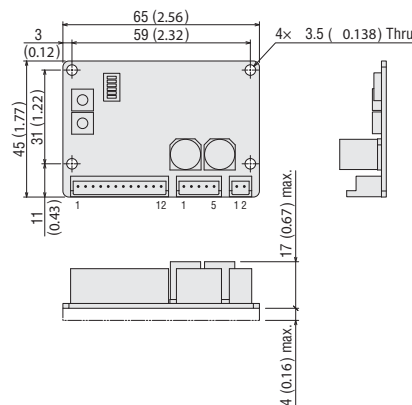

2-Phase
Motors
PKP

Features
Product
Line

Product
Number
Product Line

Standard
Type

High-
Resolution
Type

Flat Type

SH
Geared
Type

CS
Geared
Type

General
Specifications/
Inner Wiring
Diagram of Motor

5-Phase
Motors
PKP

Features
Product
Line

Product
Number
Product Line

Standard
Type

High-
Resolution
Type

TS
Geared
Type

General
Specifications/
Inner Wiring
Diagram of Motor

Driver for
2-Phase/
5-Phase Motors

Accessories

List of Applicable Motors

Bipolar Driver for 2-Phase Stepper Motors

Driver Product Name		Motor Drive Current	Applicable Motor
Right Angle Type with Installation Plate	Without Installation Plate		
CVD205BR-K	CVD205-K	0.5 A/Phase	PKP213D
CVD206BR-K	CVD206-K	0.6 A/Phase	PKP214D
CVD215BR-K	CVD215-K	1.5 A/Phase	PKP22□D15, PKP23□D15, PKP24□MD15, PKP262FD
CVD223BR-K	CVD223-K	2.3 A/Phase	PKP23□D23
CVD223FBR-K	CVD223F-K	2.3 A/Phase	PKP24□D08■2, PKP24□D15■2, PKP24□D23■2
CVD228BR-K	CVD228-K	2.8 A/Phase	PKP26□D14■2, PKP26□D28■2, PKP26□MD28
CVD242BR-K	—	4.2 A/Phase	PKP26□D42
CVD245BR-K	—	4.5 A/Phase	PKP29□D

- A number indicating the length of the motor case is entered where the box □ is located within the names of the applicable motors.
- Either **A** (single shaft) or **B** (double shaft) indicating the configuration is specified where the box ■ is located in the names of the applicable motors.
- The applicable motors are listed such that the available combinations with the driver are distinguishable.
Combinations with the encoder type or geared type are also available.
For details on the product name, please see the Oriental Motor website.

Driver for 5-Phase Stepper Motors

Driver Product Name		Motor Drive Current	Applicable Motor
Right Angle Type with Installation Plate	Without Installation Plate		
CVD503BR-K	CVD503-K	0.35 A/Phase	PK513, PK52□
CVD507BR-K	CVD507-K	0.75 A/Phase	PK52□H, PK54□
CVD512BR-K	CVD512-K	1.2 A/Phase	PKP52□
CVD514BR-K	CVD514-K	1.4 A/Phase	PK56□
CVD518BR-K	CVD518-K	1.8 A/Phase	PKP54□
CVD524BR-K	CVD524-K	2.4 A/Phase	PKP56□FN24, PKP56□FMN
CVD528BR-K	—	2.8 A/Phase	PKP56□N28
CVD538BR-K	—	3.8 A/Phase	PKP56□FN38

- A number indicating the length of the motor case is entered where the box □ is located within the names of the applicable motors.
- The applicable motors are listed such that the available combinations with the driver are distinguishable.
Combinations with the encoder type and geared type are also available.
For details on the product name, please see the Oriental Motor website.

Connection and Operation (Bipolar Driver for 2-phase Stepper Motor and Driver for 5-phase Stepper Motors)

Names and Functions of Driver Parts

1 Signal Monitor Indicators

◇ LED Indicator

Indication	Color	Function	Lighting Condition
PWR/ALM	Green	Power supply indication	When power is applied
	Red	Alarm indication	When a protective function is activated (blinking)

◇ Alarm Contents

Blink Count	Function	Operating Condition
2	Overheat Protection	When the temperature of the driver board reaches 85°C (185°F)
3	Overvoltage Protection	When the power supply voltage exceeds its permissible value When a large inertial load is stopped suddenly When a large load is hoisted
5	Overcurrent Protection	When an excessive current flows to the motor's output circuit
9	EEPROM error	When data of the driver is damaged
Lighting	CPU error	When the CPU driver malfunctions

2 Function Setting Switch

Indication	No.	Function
1P/2P	1	Switches the pulse input mode between 1-pulse input mode and 2-pulse input mode.
OFF/SD	2	Switches the smooth drive function between enabled and disabled.
R2/R1	3	Use in combination with the step angle setting switch to set the step angle.
STOP	4	Switches the standstill current of motors to 25% or 50%.
OFF/FIL	5	Switches the command filter between enabled and disabled.
—	6	Not used.

3 Step Angle Setting Switch

Indication	Function
STEP	Use in combination with the R2/R1 switch to set the step angle.

Step Angle Setting Switch (STEP) Scale	R2/R1 Switch: When Set to ON (R1)		R2/R1 Switch: When Set to OFF (R2)	
	Resolution (P/R)	Step Angle	Resolution (P/R)	Step Angle
0	500	0.72°	200	1.8°
1	1000	0.36°	400	0.9°
2	1250	0.288°	800	0.45°
3	2000	0.18°	1000	0.36°
4	2500	0.144°	1600	0.225°
5	4000	0.09°	2000	0.18°
6	5000	0.072°	3200	0.1125°
7	10000	0.036°	5000	0.072°
8	12500	0.0288°	6400	0.05625°
9	20000	0.018°	10000	0.036°
A	25000	0.0144°	12800	0.028125°
B	40000	0.009°	20000	0.018°
C	50000	0.0072°	25000	0.0144°
D	62500	0.00576°	25600	0.0140625°
E	100000	0.0036°	50000	0.0072°
F	125000	0.00288°	51200	0.00703125°

4 Running Current Setting Switch

Indication	Function
RUN	Sets the motor running current.

5 I/O Signal Connector

Indication	Pin No.	I/O	Signal Name	Function
CN3	1	Input	PLS+ (CW+)	Operation command pulse signal (Rotates the motor in the CW direction when in 2-pulse input mode.)
	2		PLS- (CW-)	
	3		DIR+ (CCW+)	Rotation direction signal (Rotates the motor in the CCW direction when in 2-pulse input mode.)
	4		DIR- (CCW-)	
	5		AWO+	Stop motor excitation.
	6		AWO-	
	7	CS+	Switches the step angle.	
	8	CS-		
	9	ALM+	Output	Outputs the alarm status for the driver (normally closed).
	10	ALM-		
	11	TIM+		Output when the state of excitation of the motor is the excitation home position.
	12	TIM-		

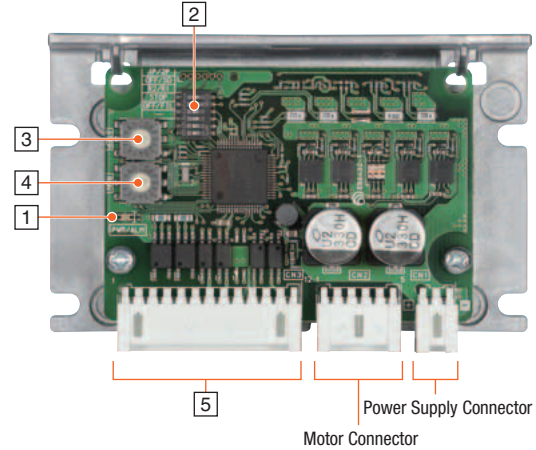

● Difference in the Motor Responsiveness Depending on the Command Filter (OFF/FIL Switch)

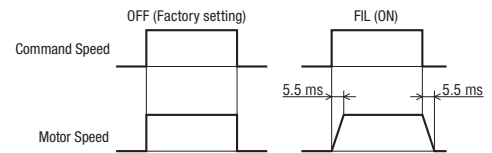

● Compared to the standard type, the high-resolution type has 2 times the resolution and 1/2 the step angle.

Example: When the R2/R1 switch is set to ON (R1) and the STEP switch is set to "0"

Resolution of High-Resolution Type: $500 \times 2 = 1000$

Step Angle of High-Resolution Type: $0.72^\circ / 2 = 0.36^\circ$

● With the geared types, the actual step angle is the value obtained by dividing the step angle by the gear ratio.

2-Phase Motors PKP

Features Product Line

Product Number Product Line

Standard Type

High-Resolution Type

Flat Type

SH Geared Type

CS Geared Type

General Specifications/ Inner Wiring Diagram of Motor

5-Phase Motors PKP

Features Product Line

Product Number Product Line

Standard Type

High-Resolution Type

TS Geared Type

General Specifications/ Inner Wiring Diagram of Motor

Driver for 2-Phase/ 5-Phase Motors

Accessories

Connection Diagrams

- When the I/O signal voltage is 5 VDC
- ◇ When the pulse input is the line driver

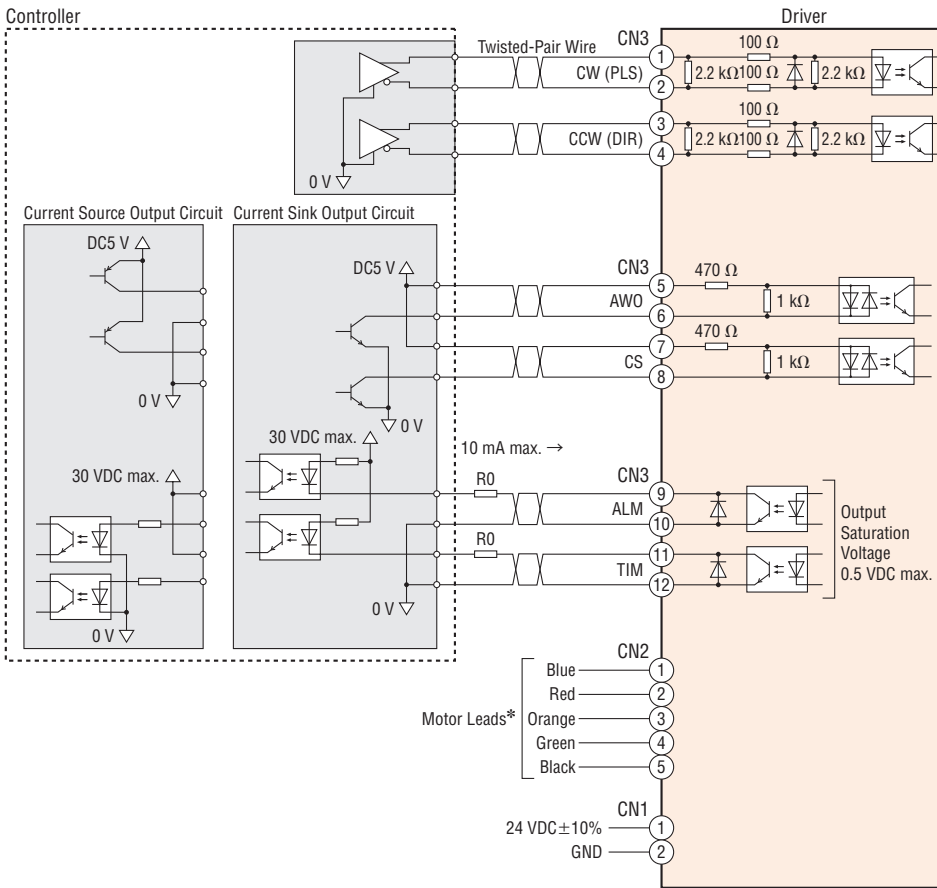

*The connector pinout differs depending on the motor. Please check the following connection table for details.

◇ 2-Phase CVD Driver Connection Table

- Motor: 2-Phase **PKP/PV** Series Bipolar 4 Lead Wires
- Driver: Bipolar Driver for 2-Phase Stepper Motors

Driver CN2 Pin No.	Model A		Model B		Model C
	Pin No.	Color	Pin No.	Color	Color
1	4	Blue	1	Blue	Blue
2	5	Red	3	Red	Red
3	-	-	-	-	-
4	2	Green	6	Green	Green
5	1	Black	4	Black	Black

● Colors in the table indicate the color of the lead wire of the separately sold connection cable.

Note

- Model A and model B motors have different pinouts. The motor will not rotate normally if the connection is wrong.

◇ 5-Phase CVD Driver Connection Table

- Motor: 5-Phase **PKP/PK** Series
- Driver: Driver for 5-Phase Stepper Motors

Driver CN2 Pin No.	Model A		Model B		Model C
	Pin No.	Color	Pin No.	Color	Color
1	5	Blue	1	Blue	Blue
2	4	Red	2	Red	Red
3	3	Orange	3	Orange	Orange
4	2	Green	4	Green	Green
5	1	Black	5	Black	Black

● Colors in the table indicate the color of the lead wire of the separately sold connection cable.

◇ When the pulse input is open collector

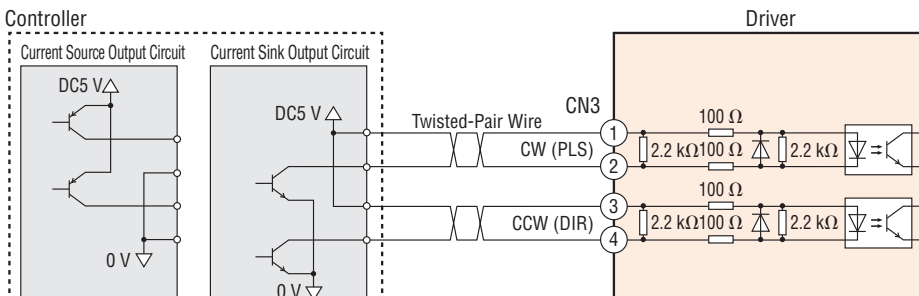

2-Phase Bipolar
5-Phase
Cables

● When the I/O signal voltage is 24 VDC

◇ When the pulse input is open collector

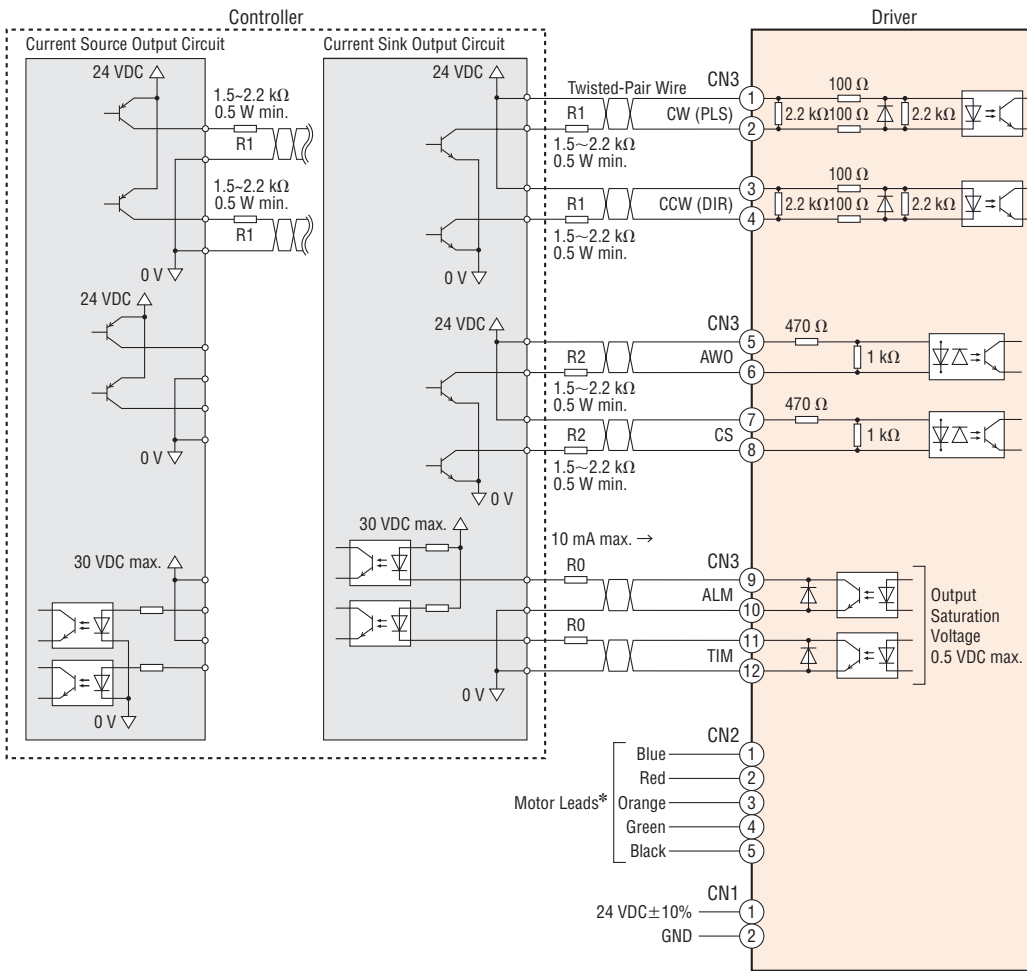

*The connector pinout differs depending on the motor. Please check the connection table on page 113 for details.

[Notes on Wiring]

◇ I/O Signal Connection

● Input Signals

- CW input and CCW input are 5 VDC. If the voltage exceeds 5 VDC, connect an external resistor R1 so that the input current becomes 7~20 mA.
Example) When connecting 24 VDC, R1: 1.5~2.2 kΩ, 0.5 W min.
- AWO input and CS input are 5 VDC. If the voltage exceeds 5 VDC, connect an external resistor R2 so that the input current becomes 5~15 mA.
Example) When connecting 24 VDC, R2: 1.5~2.2 kΩ, 0.5 W min.

● Output Signals

- Use output signals at 30 VDC 10 mA max. When the current value exceeds 10 mA, connect an external resistor R0.
- Use twisted-pair cables of AWG24~22 (0.2~0.3 mm²).
- Note that as the length of the pulse line increases, the max. transmission frequency decreases, and keep the wiring length as short as possible (2 m (6.6 ft.) max.).
- Provide a distance of 100 mm (3.94 in.) min. between the signal lines and power lines (such as power supply lines and motor lines).

◇ Power Supply Connection

- Use a wire of AWG22 (0.3 mm²). For **CVD242**, **CVD245**, **CVD528** and **CVD538**, use a wire of AWG20~18 (0.5~0.8 mm²).
- Incorrect polarities of the DC power-supply input will damage the driver. Make sure that the polarity is correct before turning the power on.

◇ Motor Cable Extension

- Use a wire of AWG22 (0.3 mm²) min. For **CVD242**, **CVD245**, **CVD528** and **CVD538**, use a wire of AWG20 (0.5 mm²) min.
Up to three cables can be used to connect the motor and driver. (Excluding **CVD242**, **CVD245**, **CVD528** and **CVD538**)
- The maximum extension length is 10 m (32.8 ft.).

◇ General

- A separate hand crimp tool is required to crimp the connector and lead wires included with the driver. Connection cables which are available as accessories (sold separately) have already had their lead wires crimped.
- If a specific wiring and layout causes the motor cable or power supply cable to generate a noise problem, shield the cable or use ferrite cores.

2-Phase
Motors
PKP

Features
Product
Line

Product
Number
Product Line

Standard
Type

High-
Resolution
Type

Flat Type

SH
Geared
Type

CS
Geared
Type

General
Specifications/
Inner Wiring
Diagram of Motor

5-Phase
Motors
PKP

Features
Product
Line

Product
Number
Product Line

Standard
Type

High-
Resolution
Type

TS
Geared
Type

General
Specifications/
Inner Wiring
Diagram of Motor

Driver for
2-Phase/
5-Phase Motors

Accessories

Cables

2-Phase
Bipolar
5-Phase

Cables

Cable System Configuration Example

Encoder Connection Cables

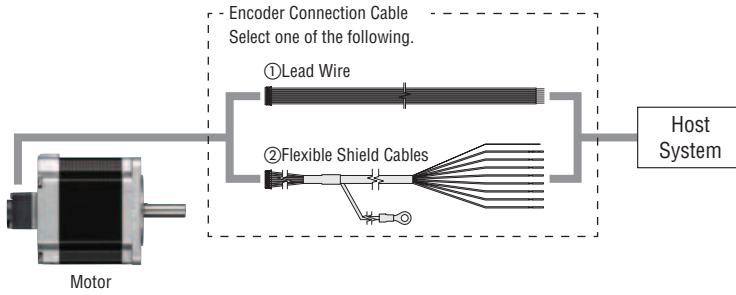

Driver Connection Cable

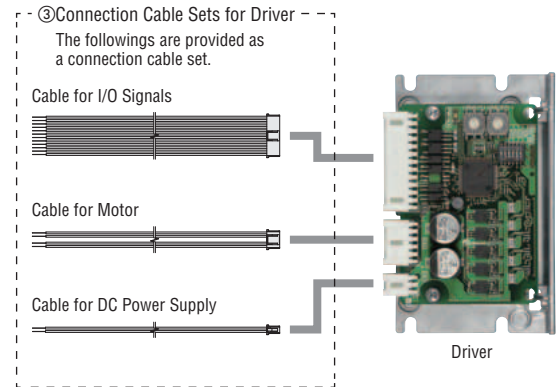

Note

- Up to three cables can be used to connect the motor and driver. Contact your local Oriental Motor sales office.
- The maximum extension lengths between the motor and driver is 10 m (32.8 ft.).

Electromagnetic Brake Connection Cable

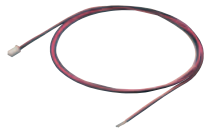
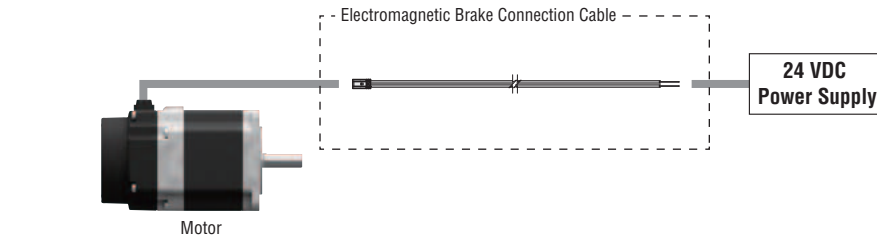

Product Line

Product Name	Applicable Motor	Length L m (ft.)	Conductor AWG	List Price
LCM02A-006	PKP24 □ M2,	0.6 (2)	22 (0.3 mm ²)	\$6.00
LCM02A-010	PKP26 □ M2	1 (3.3)		

This is an electromagnetic brake connection cable with an electromagnetic brake connector on the motor side. An electromagnetic brake with connector type connection can be used. For cable dimensions, check the specifications and dimensions page for each motor.

① Encoder Connection Cable - Lead Wire

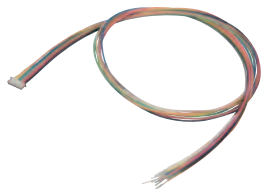

Product Line

Product Name	Applicable Motor	Encoder Type	Length L	Conductor AWG	List Price
LCE05A-006	2-Phase/5-Phase Motor with Encoder	Voltage	0.6 m (2 ft.)	26 (0.13 mm ²)	\$11.00
LCE08A-006		Line Driver			

This is an encoder connection cable with a motor-side connector. For cable dimensions, please refer to the specification and dimensions page for each motor.

② Encoder Flexible Shield Connection Cable

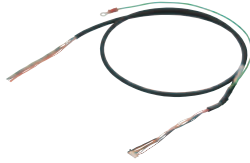

● Product Line

Product Name	Applicable Motor	Length L m (ft.)	Conductor AWG	List Price
CCO10E1R	2-Phase/5-Phase Motor with Encoder	1 (3.3)	26 (0.13 mm ²)	\$50.00
CCO20E1R		2 (6.6)		\$79.00

● For dimensions, please see the Oriental Motor website.

These are flexible shield cables with crimped connectors that are used for connecting encoders and controllers. There is a protruding shield ground wire for easy grounding.

③ Connection Cable Sets for Driver

Motor, I/O signal, and DC power supply connection cables that connect to the driver are available as a set. The connector is on the driver end.

● Product Line

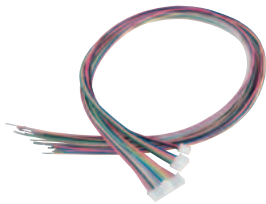

Product Name	Applicable Drivers	Connector	Connector Product Name	Length L1	Length L2	Conductor AWG	List Price		
LCS04SD5	CVD503, CVD507 CVD512, CVD514 CVD518, CVD524	For Motor	51103-0500	0.6 m (2 ft.)	10 mm (0.4 in)	22 (0.3 mm ²)	\$25.00		
		For Power Supply	51103-0200						
		For I/O Signal	51103-1200						
LCS05SD5	CVD528, CVD538	For Motor	51067-0500			0.6 m (2 ft.)	10 mm (0.4 in)	20 (0.5 mm ²)	\$29.00
		For Power Supply	51067-0200						
		For I/O Signal	51103-1200						
LCS01CVK2	CVD205, CVD206 CVD215, CVD223 CVD228	For Motor	51103-0500	0.6 m (2 ft.)	10 mm (0.4 in)			22 (0.3 mm ²)	\$27.00
		For Power Supply	51103-0200						
		For I/O Signal	51103-1200						
LCS02CVK2	CVD242, CVD245	For Motor	51067-0500			0.6 m (2 ft.)	10 mm (0.4 in)	20 (0.5 mm ²)	\$29.00
		For Power Supply	51067-0200						
		For I/O Signal	51103-1200						

● The applicable driver names are listed such that the product names are distinguishable.

● Dimensions

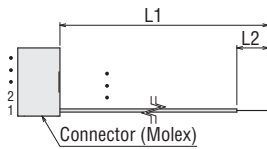

● Connector Arrangement

◇ For Motor

● LCS0□SD5

Pin No.	Wire Color
1	Blue
2	Red
3	Orange
4	Green
5	Black

● LCS0□CVK2

Pin No.	Wire Color
1	Blue
2	Red
3	—
4	Green
5	Black

● LCS01CMK2

Pin No.	Wire Color
1	Blue
2	White
3	Red
4	Black
5	Yellow
6	Green

◇ For Power Supply

● Common for all Cables

Pin No.	Wire Color
1	Red
2	Black

◇ For I/O Signal

● Common for all Cables

Pin No.	Wire Color
1	Brown
2	Red
3	Orange
4	Yellow
5	Green
6	Blue
7	Purple
8	Gray
9	White
10	Black
11	Brown
12	Red

2-Phase Motors
PKP

Features Product Line

Product Number Product Line

Standard Type

High-Resolution Type

Flat Type

SH Geared Type

CS Geared Type

General Specifications/
Inner Wiring Diagram of Motor

5-Phase Motors
PKP

Features Product Line

Product Number Product Line

Standard Type

High-Resolution Type

TS Geared Type

General Specifications/
Inner Wiring Diagram of Motor

Driver for 2-Phase/
5-Phase Motors

Accessories

Accessories

For more information, please check our website or contact our customer service center. www.orientalmotor.com

2-Phase
Bipolar
5-Phase

Cables

Flexible Coupling RoHS



Coupling Selection Table

Applicable Product		Coupling Type	Motor Shaft Diameter mm (in.)	Driven Shaft Diameter mm (in.)								
Type	Motor Frame Size			Applicable Motor	04	05	06	F04	08	10	12	
					φ4 (φ0.1575)	φ5 (φ0.1969)	φ6 (φ0.2362)	φ6.35 (φ0.2500)	φ8 (φ0.3150)	φ10 (φ0.3937)	φ12 (φ0.4724)	
High-Torque Type	20 mm (0.79 in.)	PKP213	MCS14	04	φ4 (φ0.1575)	●	●	●				
	28 mm (1.10 in.)	PKP223	MCS14	05	φ5 (φ0.1969)	●	●	●				
		PKP523										
		PKP225 PKP525										
	35 mm (1.38 in.)	PKP233 PKP235	MCS14	05	φ5 (φ0.1969)	●	●	●				
	42 mm (1.65 in.)	PKP243 PKP244 PKP544	MCS14	05	φ5 (φ0.1969)	●	●	●				
		PKP246 PKP546	MCS20	05	φ5 (φ0.1969)		●	●	●	●	●	
	56.4 mm (2.22 in.)	PKP264* PKP564	MCS20	F04	φ6.35 (φ0.2500)		●	●	●	●	●	
		PKP266* PKP268* PKP566 PKP568	MCS30	F04	φ6.35 (φ0.2500)		●	●	●	●	●	
		PKP564 PKP566	MCS20	08	φ8 (φ0.3150)		●	●	●	●	●	
60 mm (2.36 in.)	PKP564 PKP566	MCS20	08	φ8 (φ0.3150)		●	●	●	●	●		
	PKP569	MCS30	08	φ8 (φ0.3150)		●	●	●	●	●	●	

- The applicable motor products are listed such that the coupling can be determined.
- These couplings can also be used with a motor with an encoder.
- *For 8 mm (0.3150 in.) front motor shaft, use **MCS2008**.

Motor Mounting Brackets

The installation bracket base is built with holes large enough to allow for adjustments of belt tension after a motor is installed.

● Product Line

◇ For Standard Type, High-Resolution Type

Material: Aluminum Alloy (SPCC)*

Product Name	List Price	Motor Frame Size	Applicable Product
PFB28A	\$26.00	28 mm (1.10 in.)	PKP22 □, PKP52 □
PAFOPA	\$13.00	42 mm (1.65 in.)	PKP24 □
PALWOP			PKP54 □
PALW1P	\$15.00	50 mm (1.97 in.)	PKP25 □
PALW2P-2	\$17.00	56.4 mm (2.22 in.)	PKP26 □, PKP56 □ PK26 □
PALW2P-5		60 mm (2.36 in.)	PKP56 □ F
PALW4P-2	\$19.00	85 mm (3.35 in.)	PKP29 □

*Brackets contain the specifications for **PFB28A**.

- These installation brackets can be perfectly fitted to the pilot of the stepper motors. (Excluding **PALOPA**)

◇ For **SH** Geared Type

Material: Aluminum Alloy (SPCC)*

Product Name	List Price	Motor Frame Size	Applicable Product
PFB28A	\$26.00	28 mm (1.10 in.)	PKP223
SOL0A	\$23.00	42 mm (1.65 in.)	PKP243
SOL2A	\$27.00	60 mm (2.36 in.)	PKP264

*Brackets contain the specifications for **PFB28A**.

◇ For **CS** Geared Type

Material: Aluminum Alloy

Product Name	List Price	Motor Frame Size	Applicable Product
SOL0B	\$23.00	42 mm (1.65 in.)	PKP243

◇ For **TS** Geared Type

Material: Aluminum Alloy

Product Name	List Price	Motor Frame Size	Applicable Product
SOL0B	\$23.00	42 mm (1.65 in.)	PKP54 □
SOL2M4	\$27.00	60 mm (2.36 in.)	PKP56 □



Mounting Brackets for Circuit Products

These are brackets for installation on a DIN rail.

<MADP07 usage example>

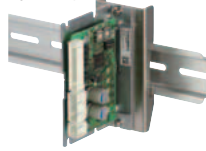

● Product Line

Material: SPCC

Product Name	List Price	Applicable Drivers	Surface Treatment
MADP07	\$11.00	CVD□□□BR-K CVD□□□B-K	Electroless nickel plating

Circuit Product Cover

This is a protection cover to prevent contact with the circuit board. Available for the right angle type driver with an installation plate.

<Application Example>



● Product Line

Material: Resin

Product Name	List Price	Applicable Drivers
PADC-CVD	\$14.00	CVD□□□BR-K

Clean Dampers

Mechanical dampers suppress stepper motor vibration and improve high-speed performance. An inertia body and silicon gel are hermetically sealed in a plastic case.



● This clean damper is an accessory for double shaft types.

■ Product Line

Product Name	Inertia kg·m ² (oz·in ²)	Mass g (oz)	Motor Frame Size	Applicable Product	List Price
D4CL-5.0F	34×10 ⁻⁷ (7.6)	24 (0.85)	28 mm (1.10 in.) 42 mm (1.65 in.)	PKP223, PKP225, PKP523, PKP525 PKP233, PKP235 PKP243, PKP244, PKP543, PKP544 PKP245, PKP246, PKP545, PKP546	\$42.00
D6CL-6.3F	140×10 ⁻⁷ (0.77)	62 (2.2)	50 mm (1.97 in.)	PK256, PK258	\$42.00
D6CL-8.0F	140×10 ⁻⁷ (0.77)	61 (2.2)	56.4 mm (2.22 in.)* 60 mm (2.36 in.)	PKP264, PKP266, PKP268 PK264, PK266, PKP564, PKP566 PK267, PK269, PKP568, PKP569	\$42.00
D9CL-14F	870×10 ⁻⁷ (4.8)	105 (3.7)	85 mm (2.35 in.)	PKP296, PKP299, PKP2913	\$53.00

Operating Temperature Range: -20~+80°C (-4~+176°F)

*56.4 mm (2.22 in.) **PKP26_**/**PKP56_** encoder and electromechanical brake motors, have 8 mm shaft. Use **D6CL-8.0F**.

2-Phase
Motors
PKP

Features
Product
Line

Product
Number
Product Line

Standard
Type

High-
Resolution
Type

Flat Type

SH
Geared
Type

CS
Geared
Type

General
Specifications/
Inner Wiring
Diagram of Motor

5-Phase
Motors
PKP

Features
Product
Line

Product
Number
Product Line

Standard
Type

High-
Resolution
Type

TS
Geared
Type

General
Specifications/
Inner Wiring
Diagram of Motor

Driver for
2-Phase/
5-Phase Motors

Accessories

Controller

Universal Controller

SCX11

The **SCX11** Universal Controller is a highly functional and sophisticated controller, equipped with program editing and execution functions. The **SCX11** is also able to control the motor via various serial ports such as USB, RS-232C and **CANopen**. Use the **SCX11** to support Oriental Motor's Pulse Input Type drivers.



Features

- 100 Sequence Programs can be Stored
- Stored Program with GUI
- USB Connection to PC
- Various Interfaces for Operation
- External Encoder Input
- Stand Alone Operation Using Sensors and Switches

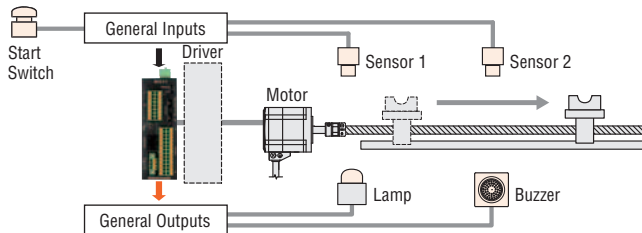

Product Line

Product Name	List Price
SCX11	\$349.00

Various Interfaces for Operation

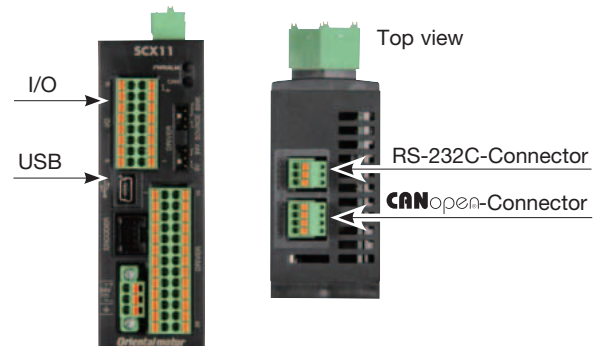

- Direct Command Operation via CANopen
- Operations Using a PC or PLC

Specifications are subject to change without notice. This catalog was published in July, 2020.

ORIENTAL MOTOR U.S.A. CORP.

Western Sales and Customer Service Center

Tel: (310) 715-3301 Fax: (310) 225-2594

Los Angeles

Tel: (310) 715-3301

San Jose

Tel: (408) 392-9735

Midwest Sales and Customer Service Center

Tel: (847) 871-5900 Fax: (847) 472-2623

Chicago

Tel: (847) 871-5900

Detroit

Tel: (734) 808-0003

Dallas

Tel: (214) 432-3386

Toronto

Tel: (905) 502-5333

Eastern Sales and Customer Service Center

Tel: (781) 848-2426 Fax: (781) 848-2617

Boston

Tel: (781) 848-2426

Charlotte

Tel: (704) 766-1335

New York

Tel: (973) 359-1100

Technical Support

Tel: (800) 468-3982 / 8:30 A.M. to 5:00 P.M., P.S.T. (M-F)
7:30 A.M. to 5:00 P.M., C.S.T. (M-F)

E-mail: techsupport@orientalmotor.com

Obtain Specifications, Online Training and Purchase Products at:
www.orientalmotor.com

Copyright ©2018 ORIENTAL MOTOR U.S.A. CORP.

This printed material uses ECF (Elemental Chlorine Free) paper and vegetable oil based inks. This combination is environmentally friendly.